

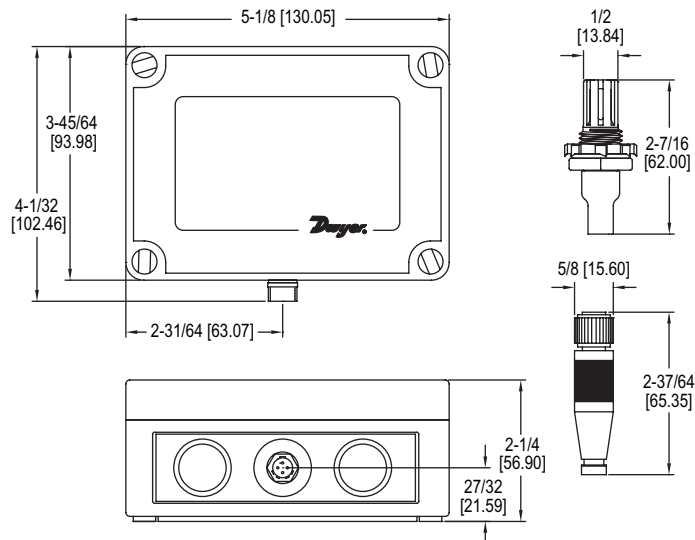

Series RH-R Temperature/Humidity Transmitter

Specifications - Installation and Operating Instructions



The **Series RH-R Humidity Transmitter** is the ideal transmitter for those applications where space is limited. The compact sensor is protected by a removable filter. It can be mounted up to 16 feet away from the weatherproof base. The Series RH-R is ideal for environmental chambers, rubber bladder burst detection systems and air handler applications.

INSTALLATION

Warning: Disconnect power supply before installation to prevent electrical shock and equipment damage.

Make sure all connections are in accordance with the job wiring diagram and in accordance with national and local electrical codes. Use copper conductors only.

Do not make changes to the cable lengths. Sensors are factory calibrated for supplied length of cable. Optional lengths are available from the factory.

Caution: Use electrostatic discharge precautions (e.g., use of wrist straps) during installation and wiring to prevent equipment damage.

Avoid locations where severe shock or vibration, excessive moisture or corrosive fumes are present. NEMA Type 4X (IP65) housings are intended for outdoor use primarily to provide a degree of protection against wind-blown dust, rain, and hose directed water.

Do not exceed ratings of this device, permanent damage not covered by warranty may result. The Series RH-R Humidity Transmitter was not designed for AC voltage operation.

SPECIFICATIONS

Service: Dry clean air.

Relative Humidity Range: 0 to 100% RH.

Temperature Range: -40 to 140°F (-40 to 60°C).

Accuracy: ±2% 10 - 90% RH; ±0.9°F @ 72°F (±0.3°C @ 25°C).

Hysteresis: ±1%.

Repeatability: ±0.1% typical.

Temperature Limits: -40 to 140°F (-40 to 60°C).

Storage Temperature: -40 to 176°F (-40 to 80°C).

Compensated Temperature Range: -4 to 140°F (-20 to 60°C).

Power Requirements: 10-35 VDC.

Output: 4-20 mA, 2 channels for humidity/temperature models (loop powered on RH).

Response Time: 15 s.

Electrical Connections: Screw terminal block.

Process Connection: 1/2 NPSM.

Conduit Connection: 1/2" (22.3 mm).

Drift: <1% RH/year.

RH Sensor: Capacitance polymer.

Temperature Sensor: Solid state band gap.

Housing Material: Polycarbonate.

Enclosure Rating: NEMA 4X (IP65).

Display Resolution: RH: 0.1%; 0.1°F (0.1°C).

Weight: 19 oz (0.54 kg).

OSA (Outside Air)

The transmitter should be mounted under an eave, shield, or in an area that is out of the elements or direct sunlight.

1. Remove the cover plugs from the face of the unit and the top cover.
2. Position the transmitter where it is to be mounted and mark the mounting holes in each corner of the housing.
3. Drill or punch out marked locations.
4. Place the transmitter box over mounting holes on wall and align. Install wall mount screws (not provided) in mounting holes.
5. Proceed with wiring according to Figure 2.
6. Replace cover and cover plugs on the face of the unit.

WIRING

Use maximum 18AWG wire for wiring terminals. Refer to Figure 1 for wiring information.

4-20 mA Output Models

4-20 mA output units may be powered with a 10-35 VDC supply. The following describes the proper wiring of these transmitters with mA output.

The Series RH-R transmitter is designed as a two-wire 4-20 mA device with two channels. The channels are common on the positive side of the current loops. Sensor excitation power is derived from the relative humidity channel, so power must always be applied to that channel. If the temperature channel is not equipped or used, it can be left disconnected. The basic two-wire connection is shown in Figure 1.

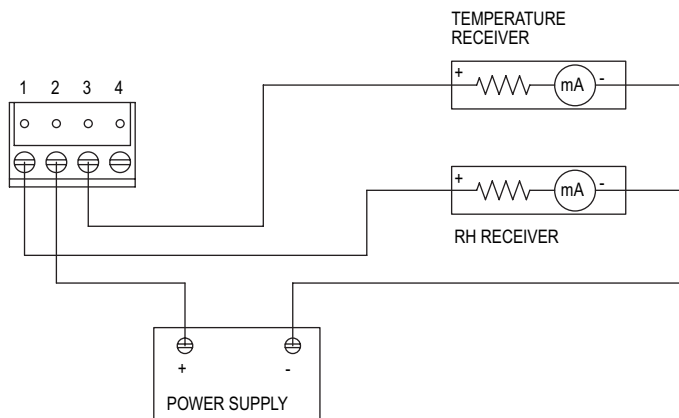

Figure 1

Note: For models with RH and temperature, the RH output must be hooked up. If the RH outputs is not required, wire the “_” terminal of the power supply to terminal 1.

Checkout

1. Verify that the unit is mounted in the correct position.
2. 4-20 mA Models:

Verify appropriate supply voltage. The transmitter requires a minimum of 10 and a maximum of 35 VDC at its connection for proper operation. Choose a power supply with a voltage and current rating which meets this requirement under all operating conditions. If the power supply is unregulated, make sure voltage remains within these limits under all power line conditions. Ripple on the supply should not exceed 100 mV. Loop Resistance – The maximum allowable loop resistance depends on the power supply voltage. Maximum loop voltage drop must not reduce the transmitter voltage below the 10 VDC minimum. Maximum loop resistance can be calculated with the following equation. V_{ps} is the power supply voltage.

$$R_{max} = \frac{V_{ps} - 10.0}{20 \text{ mA}}$$

Some receivers, particularly loop powered indicators, may maintain a fixed loop voltage to power the device. This voltage drop must also be subtracted from the power supply voltage when calculating the voltage margin for the transmitter. The following equation takes this into account. V_{rec} is the receiver fixed voltage.

$$R_{max} = \frac{V_{ps} - 10.0 - V_{rec}}{20 \text{ mA}}$$

MAINTENANCE

Upon final installation of the Series RH-R Temperature/Humidity Transmitter and the companion receiver, no routine maintenance is required. A periodic check of the system calibration is recommended. The Series RH-R is not field serviceable and should be returned if repair is needed (field repair should not be attempted and may void warranty). Be sure to include a brief description of the problem plus any relevant application notes. Contact customer service to receive a return goods authorization number before shipping.



SCATTERGOOD & JOHNSON LTD

ELECTRICAL ENGINEERING & FLUID CONTROL DISTRIBUTORS

Est.1899

At Scattergood & Johnson Ltd, we pride ourselves on being a technical distributor to specialist industries.

Working with a range of quality product suppliers across a number of specialist markets, we are not your average 'box shifter' - we are your technical and supply chain partner.

We fully support every product we sell - for free! Our internal team and external sales engineers can answer any product or application question, no matter the complexity.

Backing up this technical ability is a range of 50,000+ products available from stock for nationwide next day delivery (same day if required!), or you can collect what you need from any of our trade counters around the UK.

Select your specialist interest below to learn more about how we can help.



Online, In Branch and On the Road - Scattergood & Johnson Ltd, there when you need us.

www.scatts.co.uk