



SERIES V4 | W.E. ANDERSON FLOTECT® VANE OPERATED FLOW SWITCH



FEATURES/BENEFITS

- Unique magnetically actuated switching design gives superior performance
- Features a free-swinging vane which attracts a magnet within the solid metal switch body, actuating a snap switch by means of a simple lever arm with no bellows, springs, or seals to fail
- Leak proof body machined from bar stock
- Electrical assembly can be easily replaced without removing the unit from installation so that the process does not have to be shut down
- Installs directly and easily into pipeline with a thredolet, tee, or flange (see application drawings)
- High pressure rating of 1000 psig (69 bar) with the brass body and 2000 psig (138 bar) with the 316 SS body
- Choice of custom vane calibrated for your application, Model V4, or field adjustable multilayer vane, Model V4-2-U (see set point chart)

APPLICATIONS

- Protects pumps, motors and other equipment against low or no flow
- Controls sequential operation of pumps
- Automatically starts auxiliary pumps and engines
- Stops liquid cooled engines, machines and processing when coolant flow is interrupted
- Shuts down burner when air flow through heating coil fails
- Controls dampers according to flow

DESCRIPTION

The **Series V4 Flotect® Vane Operated Flow Switch** is rugged and reliable, ideal for automatically protecting equipment and pipeline systems against damage from reduction or loss of flow. Time tested in thousands of pipeline installations and processing plants around the world this Series is Weatherproof, designed to meet NEMA 4 and Explosion-proof (listing included in specifications). This series can be used in pipes 1-1/2" and up.

SPECIFICATIONS

Service	Gases or liquids compatible with wetted materials.
Wetted Materials	Vane: 316 SS; Body: Brass or 316 SS standard; Magnet keeper: 430 SS standard, 316 SS optional; Options: Other materials also available, consult factory (e.g. PVC, hastelloy, nickel, monel, titanium).
Temperature Limit	-4 to 275°F (-20 to 135°C) standard, MT high temperature option 400°F (205°C) [MT option not UL, CSA, ATEX or IECEx] ATEX and IECEx options, ambient temperature -4 to 163°F (-20 to 73°C); Process temperature -4 to 163°F (-20 to 73°C).
Pressure Limit	Brass body 1000 psig (69 bar), 316 SS body 2000 psig (138 bar), optional 5000 psig (345 bar) available with 316 SS body and SPDT switch only.
Enclosure Rating	Weatherproof and Explosion-proof. **Listed with UL and CSA for Class I, Groups C and D; Class II, Groups E, F, and G. ATEX $\text{C} \text{C} 2813 \text{Ex} \text{II} 2 \text{G Ex db IIB T6 Gb } -20^{\circ}\text{C} \leq \text{Tamb} \leq 73^{\circ}\text{C}$. $-20^{\circ}\text{C} \leq \text{Process Temp} \leq 73^{\circ}\text{C}$. EU-Type Certificate No.: KEMA 03ATEX2383. ATEX Standards: EN 60079-0:2012+A11:2013; EN 60079-1:2014. IECEx Certified: For Ex db IIB T6 Gb $-20^{\circ}\text{C} \leq \text{Tamb} \leq 73^{\circ}\text{C}$. $-20^{\circ}\text{C} \leq \text{Process Temp} \leq 73^{\circ}\text{C}$. IECEx Certificate of Conformity: IECEx DEK 11.0071. IECEx Standards: IEC 60079-0:2011; IEC 60079-1:2014. Zone I. Also FM approved.
Switch Type	SPDT snap switch standard, DPDT snap switch optional.
Electrical Rating	UL, FM, ATEX and IECEx models 10 A @ 125/250 VAC (V~). CSA models: 5 A @ 125/250 VAC (V~); 5 A res., 3 A ind. @ 30 VDC (V---). MV option: 1 A @ 125 VAC (V~); 1 A res., .5 A ind. @ 30 VDC (V---). MT option: 5 A @ 125/250 VAC (V~). [MT and MV option not UL, CSA, FM, ATEX or IECEx].
Electrical Connections	UL and CSA models: 16 AWG, 6" (152 mm) long. ATEX and IECEx unit: Terminal block.
Conduit Connection	3/4" female NPT standard or M25 with -BSPT option.
Process Connection	1-1/2" male NPT or 1-1/2" male BSPT.
Mounting Orientation	Within 5° of vertical for proper operation. Units for horizontal installation (vertical pipe with up flow) available.
Set Point Adjustment	For universal vane: five vane combinations.
Weight	4 lb 8 oz (1.9 kg).
Agency Approvals	ATEX, CE, CSA, FM, IECEx, UL**.

**No housing option (-NH) has no approvals.

DIMENSIONS

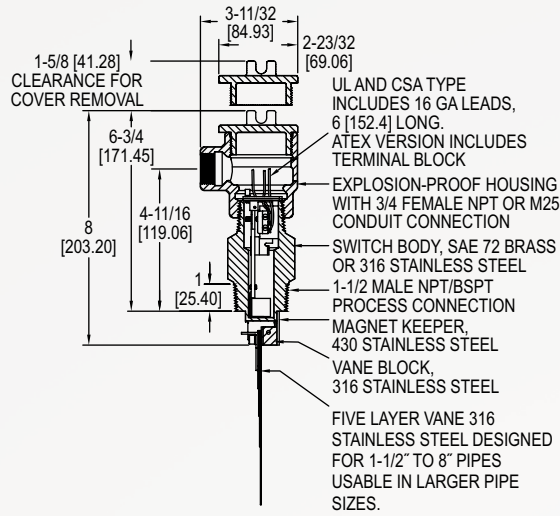

HOW TO ORDER

Use the **bold** characters from the chart below to construct a product code.

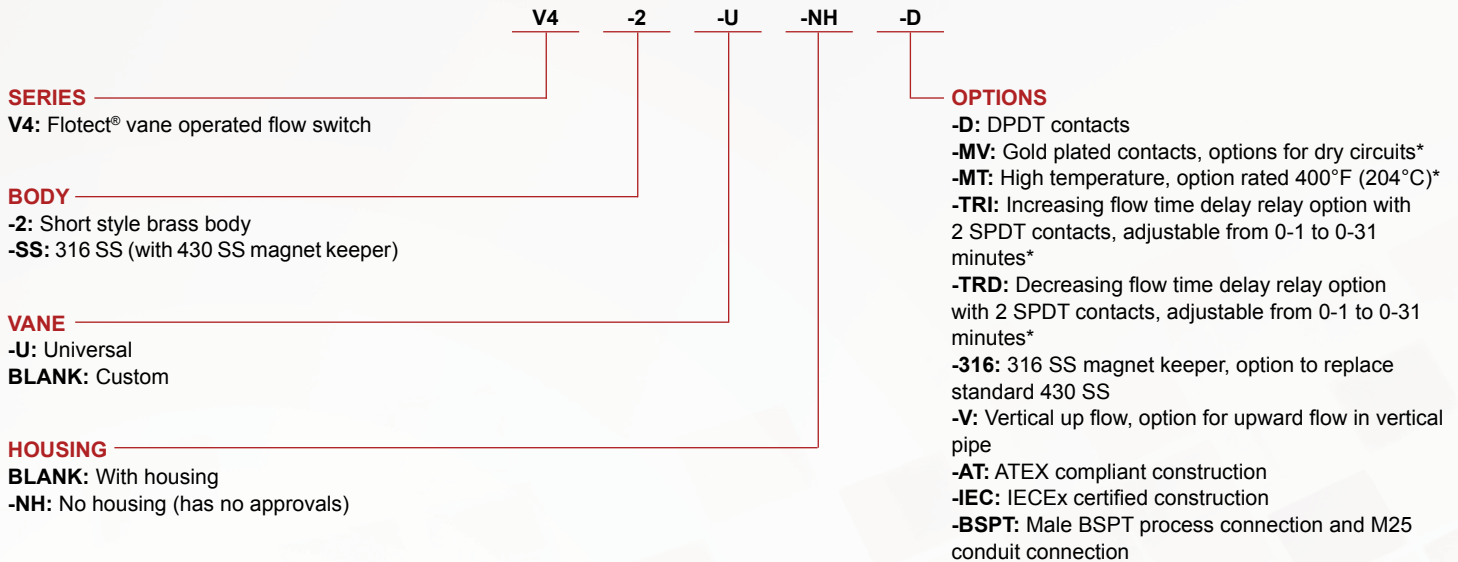

*See electrical rating in specification, no listings or approvals.

ORDER ONLINE TODAY!
dwyer-inst.com/Product/SeriesV4



DWYER INSTRUMENTS, INC.



SCATTERGOOD & JOHNSON LTD

ELECTRICAL ENGINEERING & FLUID CONTROL DISTRIBUTORS

Est.1899

At Scattergood & Johnson Ltd, we pride ourselves on being a technical distributor to specialist industries.

Working with a range of quality product suppliers across a number of specialist markets, we are not your average 'box shifter' - we are your technical and supply chain partner.

We fully support every product we sell - for free! Our internal team and external sales engineers can answer any product or application question, no matter the complexity.

Backing up this technical ability is a range of 50,000+ products available from stock for nationwide next day delivery (same day if required!), or you can collect what you need from any of our trade counters around the UK.

Select your specialist interest below to learn more about how we can help.



Online, In Branch and On the Road - Scattergood & Johnson Ltd, there when you need us.

www.scatts.co.uk