



INSTRUCTION MANUAL (ATEX / IECEx)

GNExB1X05 Flameproof Xenon Beacons

For use in Flammable Gas and Dust Atmospheres

1) Introduction

The GNExB1X05 is a flameproof beacon which is certified to meet the requirements of the ATEX directive 94/9/EC and the IECEx scheme. The beacon produces synchronised visual warning signals and can be used in hazardous areas where potentially flammable gas and dust atmospheres may be present. The GNExB1X05 has a flash energy level of 5 joules and can be used in Zone 1 and Zone 2 areas with gases in groups IIA, IIB and IIC and Temperature Classifications of T1, T2, T3, T4, T5 and T6. The unit can be used in Zone 21 and Zone 22 with dusts in groups IIIA, IIIB and IIIC and Temperature Classifications of T1, T2, T3, T4, T5 and T6.

2) Marking

All units have a rating label, which carries the following important information:-

Unit Type No. GNExB1X05

Input Voltage: DC Units 12V or 24V or 48V
AC Units 230V or 115V

Codes: Ex db IIC Gb T6 Ta -50°C to +40°C
Ex db IIC Gb T5 Ta -50°C to +55°C
Ex db IIC Gb T4 Ta -50°C to +70°C
Ex tb IIIC Db T110°C Ta -50°C to +70°C

Certificate No. DEMKO 15ATEX1448X
IECEx UL15.0003X

Epsilon x
Equipment Group and
Category:

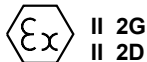

CE Marking
Notified Body No.

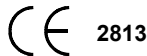

“Warnings”

POTENTIAL ELECTROSTATIC CHARGING HAZARD
DO NOT OPEN WHEN AN EXPLOSIVE
ATMOSPHERE IS PRESENT
ALL ENTRIES M20 X 1.5
IF TEMPERATURE EXCEEDS 70°C AT ENTRY OR 80°C AT
BRANCHING POINT USE SUITABLE RATED CABLE AND CABLE
GLANDS

3) Type Approval Standards

The beacons have an EC Type examination certificate and IECEx certificate of conformity issued by UL and have been approved to the following standards:

EN IEC 60079-0:2018 / IEC60079-0:2017 (Ed 7): Explosive Atmospheres - Equipment. General requirements
EN60079-1:2014 / IEC60079-1:2014 (Ed 7): Explosive Atmospheres - Equipment protection by flameproof enclosures "d"
BS EN 60079-31:2014 / IEC 60079-31:2013 (Ed 2): Explosive Atmospheres - Equipment dust ignition protection by enclosure "t"

4) Installation Requirements

The beacons must only be installed by suitably qualified personnel in accordance with the latest issues of the relevant standards:

EN60079-14 / IEC60079-14: Explosive atmospheres - Electrical installations design, selection and erection
EN60079-10-1 / IEC60079-10-1: Explosive atmospheres - Classification of areas. Explosive gas atmospheres
EN60079-10-2 / IEC60079-10-2: Explosive atmospheres - Classification of areas. Explosive dust atmospheres

The installation of the units must also be in accordance with any local codes that may apply and should only be carried out by a competent electrical engineer who has the necessary training.

5) Zones, Gas Group, Category, IP Rating and Temperature Classification

The units can be installed in locations with the following conditions:

Area Classification Gas:

Zone 1	Explosive gas air mixture likely to occur in normal operation.
Zone 2	Explosive gas air mixture not likely to occur, and if it does, it will only exist for a short time.

Gas Groupings:

Group IIA	Propane
Group IIB	Ethylene
Group IIC	Hydrogen and Acetylene

Temperature Classification:

T1	450°C
T2	300°C
T3	200°C
T4	135°C
T5	100°C (Up to 55°C Ambient)
T6	85°C (Up to 40°C Ambient)

Area Classification Dust:

Zone 21	Explosive dust air mixture likely to occur in normal operation.
Zone 22	Explosive dust air mixture not likely to occur, and if it does, it will only exist for a short time.

Dust Groupings:

Group IIIA	Combustible Flyings
Group IIIB	Non-conductive Dust
Group IIIC	Conductive Dust

IP Rating: IP66 to EN/IEC60079-0 and EN/IEC60529

Equipment Category: 2G/D

Ambient Temperature Range: -50°C to +70°C

Maximum Surface Temperature for Dust Applications: 110 °C

6) Beacon Location and Mounting

The location of the beacons should be made with due regard to the area over which the warning signal must be visible. They should only be fixed to services that can carry the weight of the unit.

The beacons should be securely bolted to a suitable surface using the 7mm diameter bolt holes in the base of the unit (see figure 1).

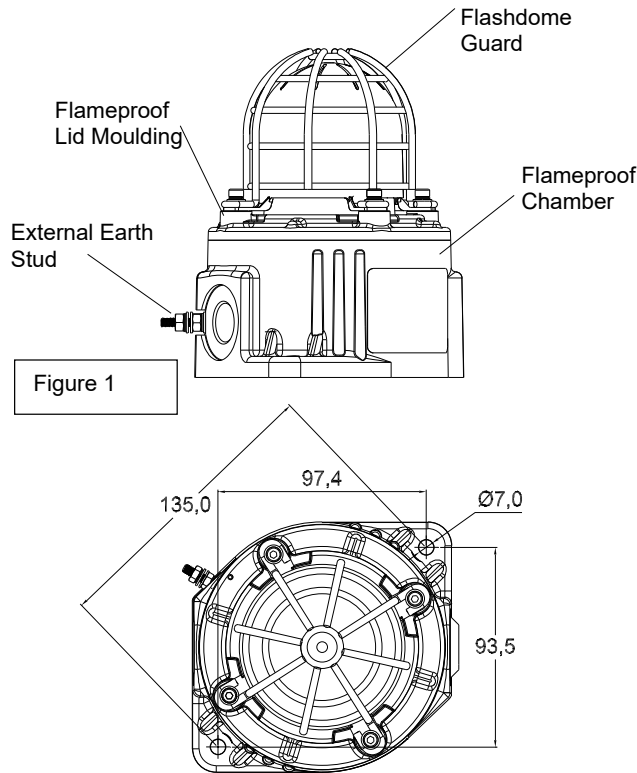

7) Access to the Flameproof Enclosure

In order to connect the electrical supply cables to the beacon it is necessary to remove the flameproof cover to gain access to the flameproof chamber. To access the Ex d chamber, loosen the M3 grub screw on the beacon cover. Open the enclosure by turning the beacon cover counterclockwise and remove the cover taking extreme care not to damage the flameproof threads in the process (see figure 2).

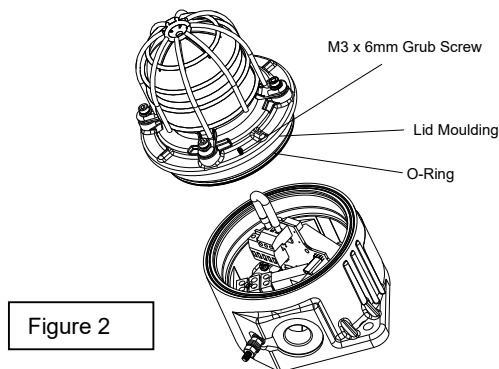

On completion of the installation the flameproof threaded joints should be inspected to ensure that they are clean and that they have not been damaged during installation. Flameproof threaded joints are not intended to be repaired. Also check that the 'O' ring seal is in place. When fitting the flameproof cover ensure the thread is engaged correctly. Fully tighten the cover all the way, ensure no gap is visible between the cover and base of the beacon enclosure. Tighten the M3 grub screw.

8) Power Supply Selection

It is important that a suitable power supply is used to run the beacons. The power supply selected must have the necessary capacity to provide the input current to all of the beacons

The following table shows the input current taken by the various beacons:

Type No.	Nominal Voltage	Nominal Current	Rated Voltage Range	Max. Rated Current
GNExB1X05	12Vdc	437mA	10-14Vdc	587mA
GNExB1X05	24Vdc	254mA	20-28Vdc	266mA
GNExB1X05	48Vdc	158mA	42-54Vdc	175mA
GNExB1X05	115Vac	95mA	110-125Vac 50/60Hz	121mA
GNExB1X05	230Vac	54mA	220-240Vac 50/60Hz	88mA

A supply voltage variation of +/-10% outside the voltage range is permissible.

Nominal current at nominal voltage and 1Hz flash rate

Max rated current at worst case supply voltage and flash rate.

9) Cable Selection

When selecting the cable size, consideration must be given to the input current that each unit draws (see table above), the number of beacons on the line and the length of the cable runs. The cable size selected must have the necessary capacity to provide the input current to all of the beacons connected to the line.

SAFETY WARNING: The cable entry temperature may exceed +70°C or the cable branching point temperature may exceed 80°C at high ambient temperatures and therefore suitable heat resisting cables and cable glands must be used, rated 80°C for ambient temperatures of 55°C and rated 95°C for ambient temperatures of 70°C.

10) Earthing

Both AC and DC beacon units can be connected to an earth. The units are provided with internal and external earth terminals which are both located on the terminal chamber section of the unit (see figures 3 and 4).

11) Cable Glands

The cable gland entries have an M20 x 1.5 entry thread. Only suitably rated and ATEX / IECEx certified cable glands which must be suitable for the type of cable being used.

When only one cable entry is used the other entry must be closed with suitably rated and ATEX / IECEx certified blanking plugs.

For combustible dust applications, the cable entry device and blanking elements shall be in type of explosion protection and shall have an IP 6X rating.

If a high IP (Ingress Protection) rating is required then a suitable sealing washer must be fitted under the cable glands or blanking plugs. A minimum ingress protection rating of IP6X must be maintained for installations in explosive dust atmospheres.

12) Cable Connections

Electrical connections are to be made into the terminal blocks on the PCBA located in the flameproof enclosure. See section 7 of this manual for access to the flameproof enclosure. A five-way terminal block is provided on both AC and DC beacons. There are two live, two neutral and an Earth terminal for the input and output wiring on AC units. DC units have two +ve, two -ve and an S2 terminal for the input and output wiring.

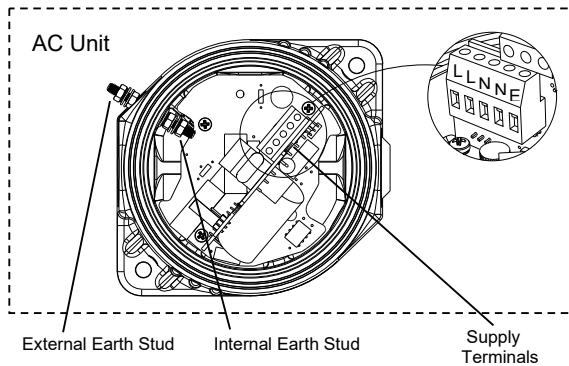

Figure 3

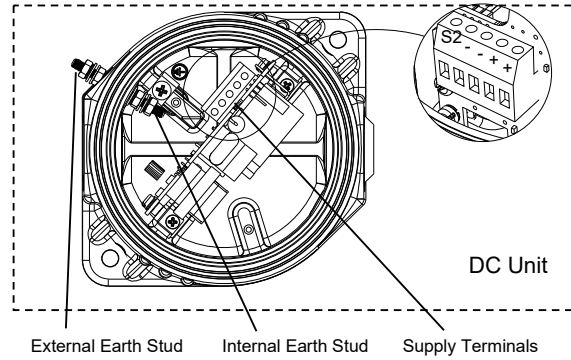
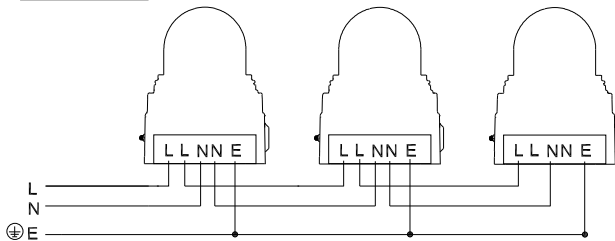
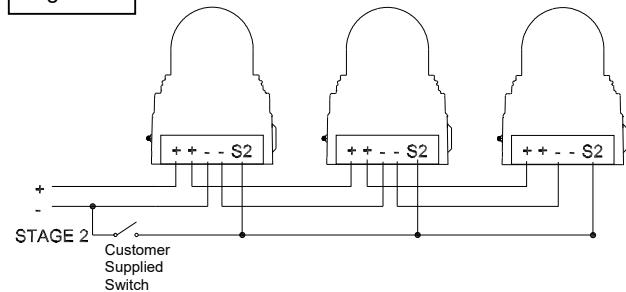

Figure 4



Wires having a cross sectional area of up to 2.5mm² can be connected to each terminal way. If an input and output wire is required the 2-off Live/Neutral or +/- terminals can be used. If fitting 2-off wires to one terminal way the sum of the 2-off wires must be a maximum cross sectional area of 2.5mm². Strip wires to 8mm. When connecting wires to the terminals great care should be taken to dress the wires so that when the cover is inserted into the chamber the wires do not exert excess pressure on the terminal blocks. This is particularly important when using cables with large cross sectional areas such as 2.5mm².

Internal earthing connections on AC units should be made to the Internal Earth terminal on the PCBA. The earth conductor should be at least equal in size and rating to the incoming power conductors.

External earthing connections should be made to the M4 earth stud, using a ring crimp terminal to secure the earth conductor to the earth stud between the two M4 stainless steel flat washers, then reassemble the M4 spring washer and tighten the M4 nut to ensure that the cable lug is secured against loosening and twisting. The external earth conductor should be at least 4mm² in size.

13) Flash Patterns (DC Units Only)

The GNExB1X05 DC beacons can produce three different flash patterns as listed below. The flash patterns are set internally by the selection of pin headers. The flash pattern set can be changed externally to produce a second stage by connecting terminal S2 to -ve supply line whilst powering the +ve and -ve supply terminals.

The AC Beacons only flash at 1Hz.

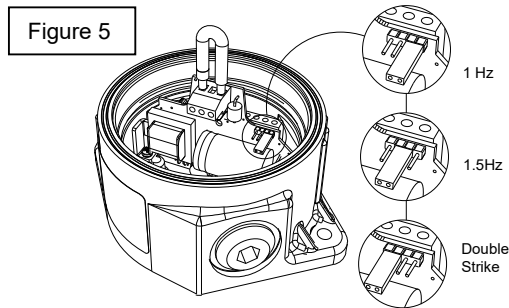

Stage 1

1Hz
1.5Hz
Double Strike

Stage 2

Double Strike
Double Strike
Double Strike

14) Synchronised Operation

All GNExBG1X05 beacons that are connected to the same supply line will have a synchronised flash rate at one flash every second. To ensure that the units will be synchronised check that the pin header is set to 1Hz (see Figure 5).

15) End of Line Monitoring (DC Units)

On the GNExBG1X05 DC beacons, dc reverse line monitoring can be used if required. All DC units have a blocking diode fitted in their supply input lines. An end of line monitoring diode or an end of line monitoring resistor can be connected across the +ve and -ve terminals in the flameproof chamber. If an end of line resistor is used it must have a minimum resistance value of 3k3 ohms and a minimum wattage of 0.5W or a minimum resistance value of 500 ohms and a minimum wattage of 2W.

16) Maintenance, Overhaul and Repair

Maintenance, repair and overhaul of the equipment should only be carried out by suitably qualified personnel in accordance with the current relevant standards:

EN60079-19/IEC60079-19 Explosive atmospheres - Equipment repair, overhaul and reclamation
EN60079-17/IEC60079-17 Explosive atmospheres - Electrical installations inspection and maintenance

Units must not be opened while an explosive atmosphere is present.

Electrostatic charging hazard - Clean only with a damp cloth.

17) Adapter options

The GNEx Beacon Range can be supplied with the following types of adapters:

M20 to ½" NPT
M20 to ¾" NPT
M20 to M25

It is important to note that stopping plugs cannot be fitted onto adapters, only directly onto the M20 entries.

If the installation is made using conduit, openings must have a sealing fitting connected as close as practical to the wall of the enclosure, but in no case more than the size of the conduit or 50mm, whichever is the lesser.

18) Special Conditions of safe use

The enclosure is non-conducting and may generate an ignition-capable level of electrostatic charges under certain extreme conditions. The user should ensure that the equipment is not installed in a location where it may be subjected to external conditions that might cause a build-up of electrostatic charges on non-conducting surfaces.

The stainless steel beacon guard is not earthed and may generate an ignition-capable level of electrostatic charges. It has a capacitance of 10pF according to EN/IEC60079-0, clause 7.5.

The flashdome guard must not be removed from the unit at any time whilst in service.



SCATTERGOOD & JOHNSON LTD

ELECTRICAL ENGINEERING & FLUID CONTROL DISTRIBUTORS

Est.1899

At Scattergood & Johnson Ltd, we pride ourselves on being a technical distributor to specialist industries.

Working with a range of quality product suppliers across a number of specialist markets, we are not your average 'box shifter' - we are your technical and supply chain partner.

We fully support every product we sell - for free! Our internal team and external sales engineers can answer any product or application question, no matter the complexity.

Backing up this technical ability is a range of 50,000+ products available from stock for nationwide next day delivery (same day if required!), or you can collect what you need from any of our trade counters around the UK.

Select your specialist interest below to learn more about how we can help.



Online, In Branch and On the Road - Scattergood & Johnson Ltd, there when you need us.

www.scatts.co.uk