

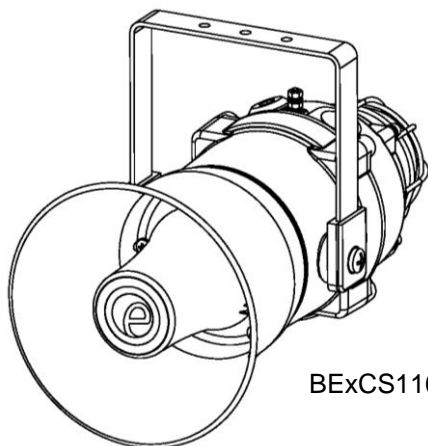

INSTRUCTION MANUAL (ATEX / IECEx)

BExCS110-05D-P and BExCS110-05D-R-P Combined Sounder / Beacon For use in Flammable Gas and Dust Atmospheres



BExCS110-05D-P

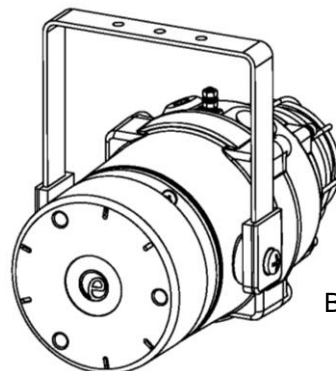

BExCS110-05D-R-P

1) Warnings



- DO NOT OPEN WHEN AN EXPLOSIVE ATMOSPHERE IS PRESENT
- DO NOT OPEN WHEN ENERGIZED
- POTENTIAL ELECTROSTATIC CHARGING HAZARD – CLEAN ONLY WITH A DAMP CLOTH
- COVER BOLTS CLASS A4-80
- USE HEAT RESISTING CABLES AND CABLE GLANDS (RATED 110°C) AT AMB. TEMPERATURES OVER 40°C

2) Rating & Marking Information

All units have a rating label, which carries the following important information: -

Model No.: BExCS110-05D-P or BExCS110-05D-R-P

Input Voltage: DC Units 12V or 24V or 48V
AC Units 115V or 230V

BExCS110-05D-P or BExCS110-05D-R-P Codes:
Ex db IIB T5 Gb Ta. -50°C to +40°C
Ex db IIB T4 Gb Ta. -50°C to +70°C
Ex tb IIIC T110°C Db Ta. -50°C to +55°C
Ex tb IIIC T125°C Db Ta. -50°C to +70°C

Certificate No. KEMA 01ATEX2223X
IECEx KEM 10.0025X

Epsilon x
Equipment Group and
Category:

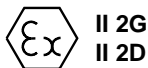

II 2G
II 2D

CE Marking
Notified Body No.

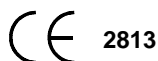

2813

The units can be installed in locations with the following conditions:

Area Classification Gas:

Zone 1	Explosive gas air mixture likely to occur in normal operation.
Zone 2	Explosive gas atmosphere not likely to occur in normal operation but may be present for short periods.

Gas Groupings:

Group IIA	Propane
Group IIB	Ethylene

Temperature Classification:

T1	450°C
T2	300°C
T3	200°C
T4	135°C
T5	100°C (up to 40°C ambient)

Area Classification Dust:

Zone 21	Explosive dust air mixture likely to occur in normal operation.
Zone 22	Explosive dust air mixture not likely to occur in normal operation, and if it does, it will only exist for a short time.

Dust Groupings:

Group IIIA	Combustible Dusts
Group IIIB	Non-Conductive Dust
Group IIIC	Conductive Dust

Maximum Surface Temperature for Dust Applications:
110°C at +55 °C ambient
125 °C at +70 °C ambient

IP Rating: IP66/67 to EN/IEC60529 and IP6X to EN/IEC60079-0, EN/IEC60079-31

Equipment Category: 2G / 2D

Equipment Protection Level: Gb / Db

Ambient Temperature Range:
-50°C to +70°C Gas Groups IIA and IIB
-50°C to +70°C Dust Groups IIIA, IIIB and IIIC

3) Type Approval Standards

The combined sounder beacon carries an EC Type Examination Certificate and IECEx Certificate of Conformity, and have been certified to comply with the following standards:

EN60079-0:2012 + A11 and EN IEC 60079-0 :2018 / IEC60079-0:2017 (Ed 7): Explosive Atmospheres - Equipment. General requirements

EN60079-1:2014 / IEC60079-1:2014 (Ed 7): Explosive Atmospheres - Equipment protection by flameproof enclosures "d"

EN 60079-31:2014 / IEC60079-31:2013 (Ed 2): Explosive Atmospheres - Equipment dust ignition protection by enclosure "t"

4) Installation Requirements

The combined sounder beacon must only be installed by suitably qualified personnel in accordance with the latest issues of the relevant standards:

EN60079-14 / IEC60079-14: Explosive atmospheres - Electrical installations design, selection and erection

EN60079-10-1 / IEC60079-10-1: Explosive atmospheres - Classification of areas. Explosive gas atmospheres

EN60079-10-2 / IEC60079-10-2: Explosive atmospheres - Classification of areas. Explosive dust atmospheres

The installation of the combined sounder beacon must also be in accordance with any local codes that may apply and should only be carried out by a competent electrical engineer who has the necessary training.

5) Special Conditions of Use

Repair of the flamepath / flameproof joints is not permitted.

The enclosure is non-conducting and may generate an ignition-capable level of electrostatic charges under certain extreme conditions (such as high-pressure steam). The user should ensure that the equipment is not installed in a location where it may be subjected to external conditions that might cause a build-up of electrostatic charges on non-conducting surfaces.

Additionally, cleaning of the equipment should be done only with a damp cloth.

6) Location and Mounting

The location of the combined sounder beacon should be made with due regard to the area over which the warning signal must be visible. They should only be fixed to services that can carry the weight of the unit.

The BEx combined sounder beacon should be secured to any flat surface using at least two of the three 7mm fixing holes on the stainless steel U shaped mounting bracket. See Figure 1. The required angle can be achieved by loosening the two large bracket screws in the side of the unit, which allow adjustment of the combined sounder beacon in steps of 18°. On completion of the installation then two large bracket

adjustment screws on the side of the unit must be fully tightened to ensure that the unit cannot move in service.

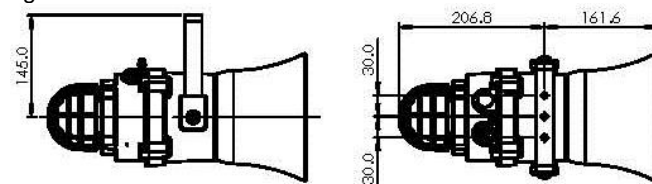

Fig. 1 Fixing Location for Combined Flare

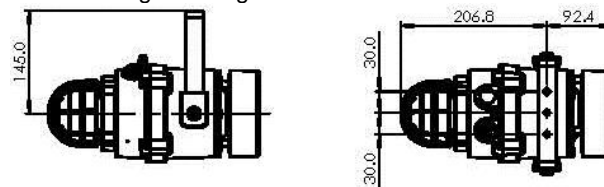

Fig. 1 Fixing Location for Combined Radial

7) Access to the Flameproof Enclosure



Warning – High voltage may be present, risk of electric shock. DO NOT open when energised, disconnect power before opening.



Warning – Hot surfaces. External surfaces and internal components may be hot after operation, take care when handling the equipment.

To access the Ex d chamber, remove the four M6 hexagon socket head screws and withdraw the flameproof cover taking extreme care not to damage the flameproof joints in the process. M6 cover screws are Class A4-80 stainless steel and only screws of this category can be used for the enclosure.

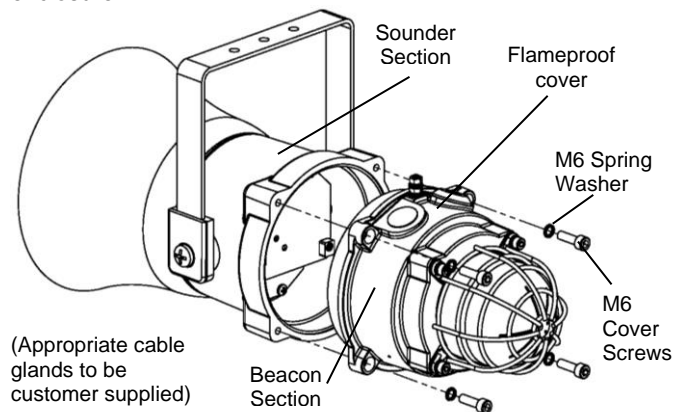

Fig. 2 Accessing the Explosion proof Enclosure.

On completion of the installation, the flameproof joints should be inspected to ensure that they are clean and that they have not been damaged during installation.

Check that the earth bonding wire between the two castings is secure and the 'O' ring seal is in place. When replacing the flameproof cover casting ensure that it is square with the flameproof chamber casting before inserting. Carefully push the cover in place allowing time for the air to be expelled. Only after the cover is fully in place should the four M6 Stainless Steel A4-80 cover bolts and their spring washer be inserted and tightened down. If the cover jams while it is being inserted, carefully remove it and try again. Never use the cover bolts to force the cover into position.

8) Power Supply Selection

It is important that a suitable power supply is used to run the equipment. The power supply selected must have the necessary capacity to provide the input current to all of the units.

The following table shows the input current taken by the various combined sounder beacons and shows the maximum voltage at which the combined sounder beacons can be operated:

Model No.	Nominal I/P Voltage	Sounder Current	Beacon Current	Max. I/P Volts
BExCS110-05D-P DC012	12Vdc	195mA	750mA	14V
BExCS110-05D-P DC024	24Vdc	265mA	300mA	28V
BExCS110-05D-P DC048	48Vdc	130mA	180mA	54V
BExCS110-05D-P DC115	115Vac	110mA	140mA	126V
BExCS110-05D-P AC230	230Vac	56mA	55mA	253V

Sounder Section

The input current to the sounder section will vary according to the voltage input level and the frequency of the tone selected. The current levels shown above are for the 440Hz Continuous tone @ nominal input voltage.

Beacon Section

The input current to the beacon section will vary according to the voltage input level. The current levels shown above are for nominal input voltage.

9) Selection of Cable, Cable Glands, Blanking Elements & Adapters

When selecting the cable size, consideration must be given to the input current that each unit draws (see table above), the number of combined sounder beacons on the line and the length of the cable runs. The cable size selected must have the necessary capacity to provide the input current to all of the combined sounder beacons connected to the line.

For ambient temperatures over +40°C the cable entry temperature may exceed +70°C and therefore suitable heat resisting cables and cable glands must be used, with a rated service temperature of at least 110°C

The dual cable gland entries have an M20 x 1.5 entry thread. To maintain the ingress protection rating and mode of protection, the cable entries must be fitted with suitably rated ATEX / IECEx certified cable glands and/or suitably rated ATEX / IECEx certified blanking devices during installation according to EN / IEC60079-14.

If a high IP (Ingress Protection) rating is required then a suitable sealing washer must be fitted under the cable glands or blanking plugs.

For use in explosive dust atmospheres, a minimum ingress protection rating of IP6X must be maintained.

The BEx combined sounder beacon range can be supplied with the following types of adapters:

M20 to ½" NPT
M20 to ¾" NPT
M20 to M25

It is important to note that stopping plugs cannot be fitted onto adapters, only directly onto the M20 entries.

Any other adapters used must be suitably rated and ATEX / IECEx certified adapters.

10) Earthing

Both AC and DC combined sounder beacon units must be connected to an earth. The units are provided with internal and external earth terminals which are both located on the terminal chamber section of the unit.

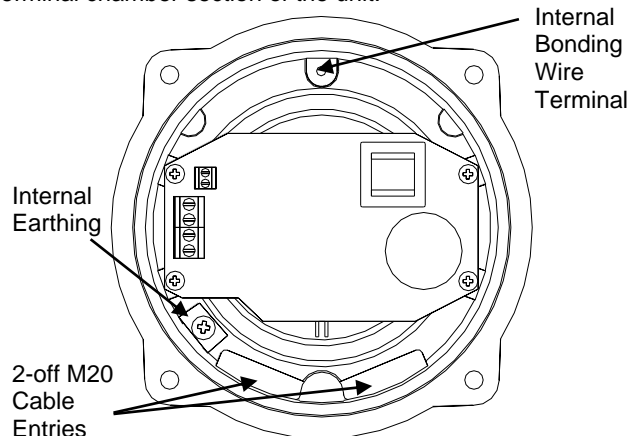

Fig. 3 Internal View of Cover

When using the internal earth terminal ensure that the stainless steel M4 flat washer is between the incoming earth wire and the enclosure.

Internal earthing connections should be made to the Internal Earth terminal in the base of the housing using a ring crimp terminal to secure the earth conductor under the earth clamp. The earth conductor should be at least equal in size and rating to the incoming power conductors.

External earthing connections should be made to the M5 earth stud, using a ring crimp terminal to secure the earth conductor to the earth stud. The external earth conductor should be at least 4mm² in size.

11) Cable Connections

The combined sounder beacon unit BExCS110-05D has separate printed circuit boards in the sounder and beacon sections. The terminals for the sounder are on the printed circuit board in the sounder section and the terminals for the beacon are on the printed circuit board in the beacon section (see figures 4a, 4b, 6a and 6b). See section 7 of this manual for access to the enclosure. See section 12 and 13 for AC and DC wiring diagrams respectively.

Wires having a cross sectional area between 0.5 mm² to 2.5mm² can be connected to each terminal way. If an input and output wire is required the 2-off Live/Neutral or +/- terminals can be used. If fitting 2-off wires to one terminal way the sum of the 2-off wires must be a maximum cross sectional area of 2.5mm². Strip wires to 8mm. Wires may also be fitted using ferrules. Terminal screws need to be tightened down with a tightening torque of 0.45 Nm / 5 Lb-in. When connecting wires to the terminals great care should be taken

to dress the wires so that when the cover is inserted into the chamber the wires do not exert excess pressure on the terminal blocks. This is particularly important when using cables with large cross sectional areas such as 2.5mm².

12) AC Wiring

A 2-way terminal block is provided on the AC Sounder for power. There are 1-off Live and 1-off Neutral terminals in total. A 3-way terminal block is provided for stage switching. There are 1-off stage 2, 1-off stage 3 and 1-off common terminals in total. A 4-way terminal block is provided on the AC beacon for power. There are 2-off Live and 2-off Neutral terminals in total.

12.1 Wiring Diagrams

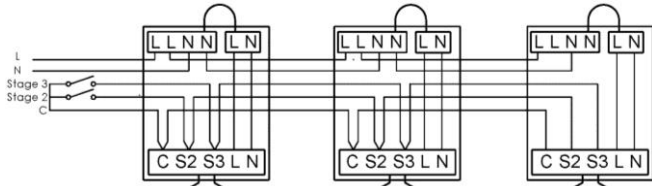

Fig 3a. BExCS110-05D AC Simplified Block Diagram for simultaneous operation

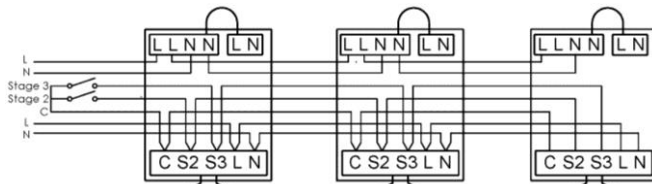
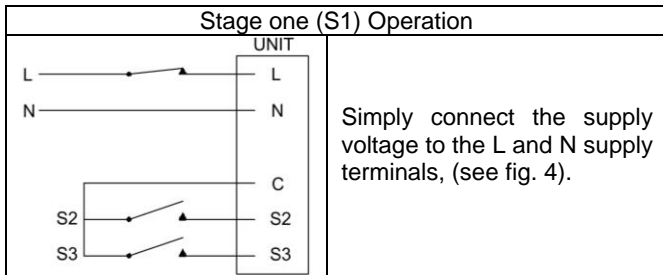

Fig 3b. BExCS110-05D AC Simplified Block Diagram for independent operation

12.2 Sounder Stage Switching

12.2.1 Units First Stage Tones



12.2.2 AC Units Second and Third Stage Tone Selection

To select the second and third stage tones on the BExCS110 AC sounder.

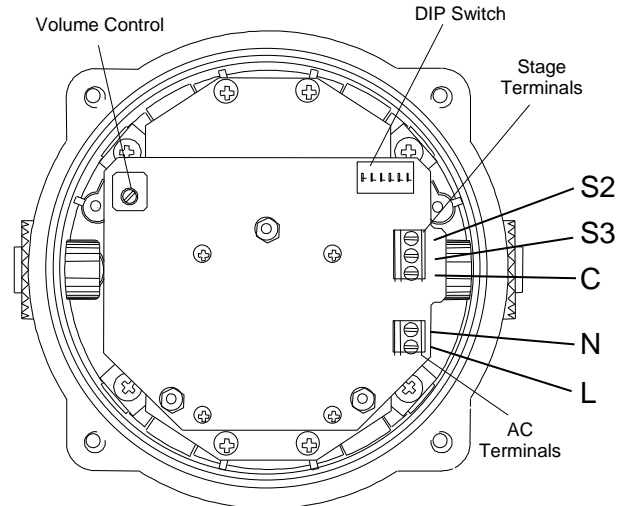
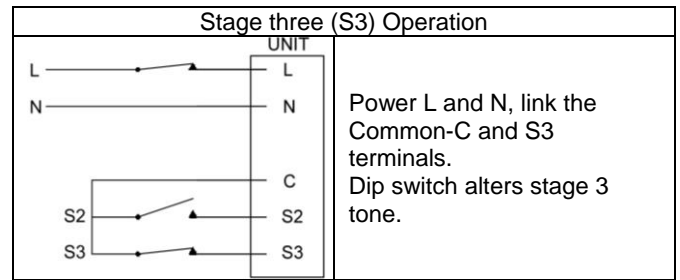
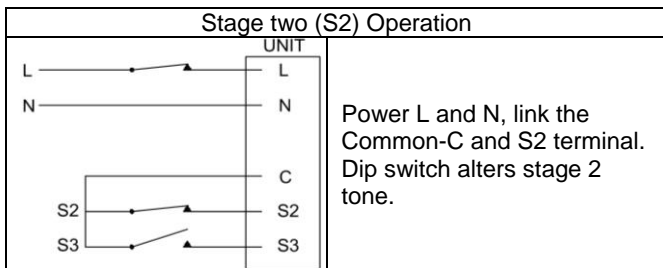

Fig. 4a Sounder AC Terminals

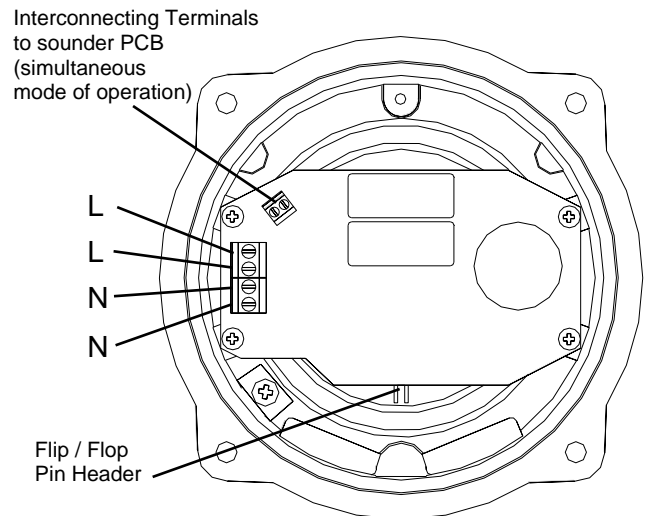

Fig. 4a Beacon AC Terminals

13) DC Wiring

A 4-way terminal block is provided on the DC Sounder. There are 1-off +ve, 1-off -ve, 1-off stage 2 and 1-off stage 3 terminals in total.

13.1 Wiring Diagrams

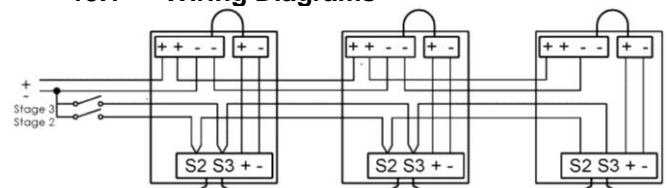

Fig 5a. BExCS110-05D AC Simplified Block Diagram for simultaneous operation (negative switching)

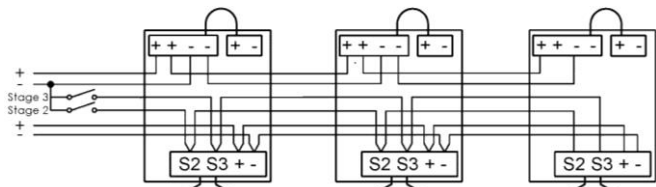

Fig 5b. BExCS110-05D AC Simplified Block Diagram for independent operation (negative switching)

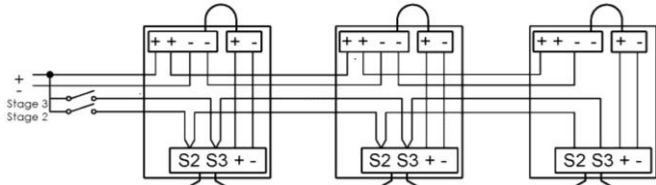

Fig 6a. BExCS110-05D AC Simplified Block Diagram for simultaneous operation (positive switching)

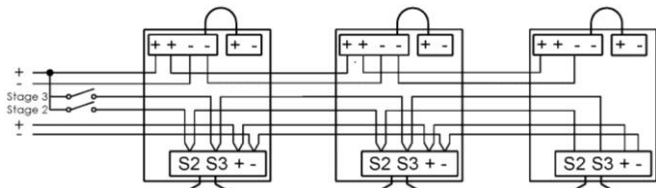

Fig 6b. BExCS110-05D AC Simplified Block Diagram for independent operation (positive switching)

For units set up for +ve switching (refer to 13.3):

Stage two (S2) Operation	
	Power +ve and -ve, link a +ve supply line to the S2 terminal. Dip switch alters stage 2 tone.
Stage three (S3) Operation	
	Power +ve and -ve, link a +ve supply line to the S3 terminal. Dip switch alters stage 3 tone.

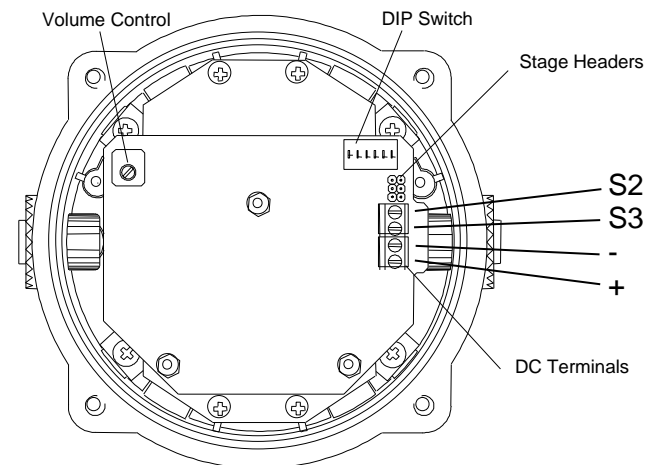

Fig. 6a DC Terminals

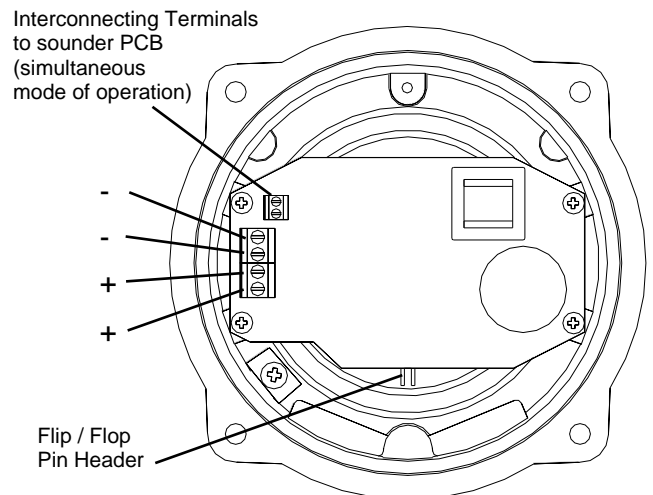

Fig. 6b Beacon DC Terminals

13.2 Stage Switching

13.2.1 Units First Stage Tones

Stage one (S1) Operation	
	Simply connect the supply voltage to the + and - supply terminals, (see fig. 6).

13.2.2 DC Units Second and Third Stage Tone Selection

For units set up for -ve switching (default setting):

Stage two (S2) Operation	
	Power +ve and -ve, link a -ve supply line to the S2 terminal. Dip switch alters stage 2 tone.
Stage three (S3) Operation	
	Power +ve and -ve, link a -ve supply line to the S3 terminal. Dip switch alters stage 3 tone.

13.3 Stage Switching Polarity (DC Units Only)

The BExCS110-05D DC sounders has the facility to use either +ve or -ve switching to change the tone to the second and third stages. Negative switching is the default setting. For -ve switching connect the two headers on the pcb to the left-hand (marked -ve) and centre pins. For +ve switching connect the headers to the right hand (marked +ve) and the centre pins. (Refer to Fig. 7)

15) Settings

15.1 Tone Selection

The sounders have 32 different tones that can be selected for the first stage alarm. The sounders can then be switched to sound second and third stage alarm tones. The tones are selected by operation of a DIP switch on the pcb for both DC and AC units. The tone table on page seven shows the switch positions for the 32 tones and which tones are available for the second and third stages. To operate the sounder on stage one simply connect the supply voltage to the normal supply terminals (+ve and -ve for DC units, L and N for AC units).

15.2 Volume Control



Warning - High noise levels above 85dB(A) during operation. High levels of noise may cause hearing loss, wear suitable ear protection when equipment is in operation.

The output level of the BEx sounder can be set by adjusting the volume control potentiometer (see Fig 9) with the exception of 12V DC units. For maximum output, set the potentiometer fully clockwise.

Volume Control Potentiometer

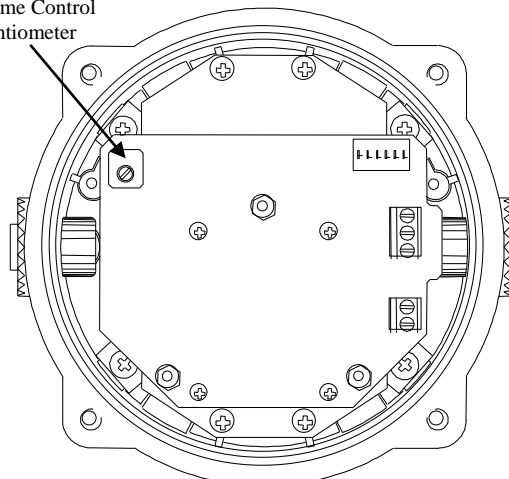

BExCS110-05D AC

Volume Control Potentiometer

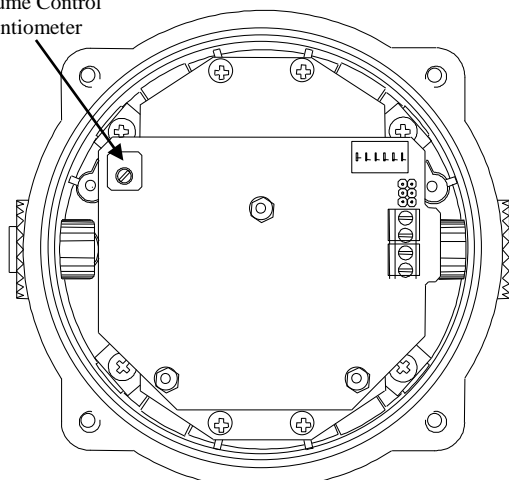

BExCS110-05D DC

Fig. 9 Location of Volume Control Potentiometer

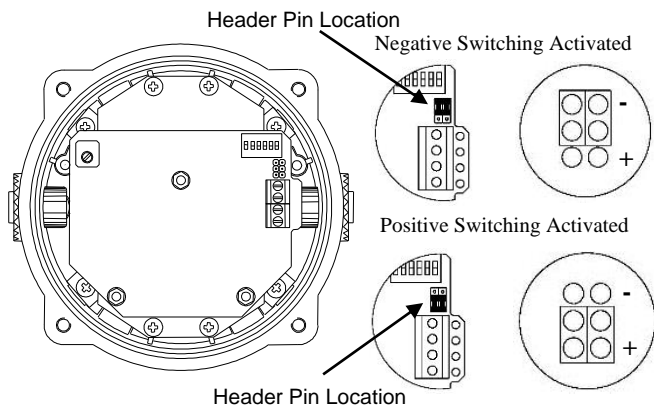

Fig. 7 Stage Switching Polarity

13.4 Line Monitoring

On BExCS110-05D DC units, dc reverse line monitoring can be used if required. All DC sounders have a blocking diode fitted in their supply input lines. An end of line monitoring diode or an end of line monitoring resistor can be connected across the +ve and -ve terminals. If an end of line resistor is used it must have a minimum resistance value of 3k3Ω and a minimum power rating of 0.5 watts or a minimum resistance value of 500Ω and a minimum power rating of 2 watts.

The resistor must be connected directly across the +ve and -ve terminals as shown in the following drawing. The resistor leads should be kept as short as possible.

End of Line Resistor

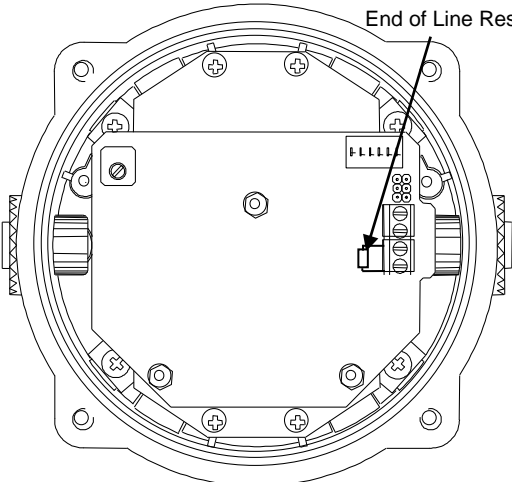

Fig. 8 End of Line Resistor Placement

14) Wiring the combined sounder/beacon for simultaneous operation

The sounder and beacon sections can be wired to the same input supply so that they operate simultaneously or they can be wired to separate input supplies so they can be operated independently (see fig. 3, 5 & 6).

If the sounder and beacon sections are connected to the same input supply. The incoming cables should be connected to the input terminals on the beacon board and the two link wires, that are supplied with the unit, should be used to link the supply from the interconnecting terminals on the beacon board down to the supply terminals on the sounder board.

15.3 Flip/Flop Operation

Two units can be mounted close to each other to form a flip-flop operation, where the beacons will flash alternately. To achieve this mode of operation, fit a pin header to the flip-flop header pins on the electronics board, i.e. the two header pins are shorted together, on one of the two beacons. The first flash on the beacon that has the header fitted will be delayed by ½ second. The two beacons will then flash alternately every ½ a second.

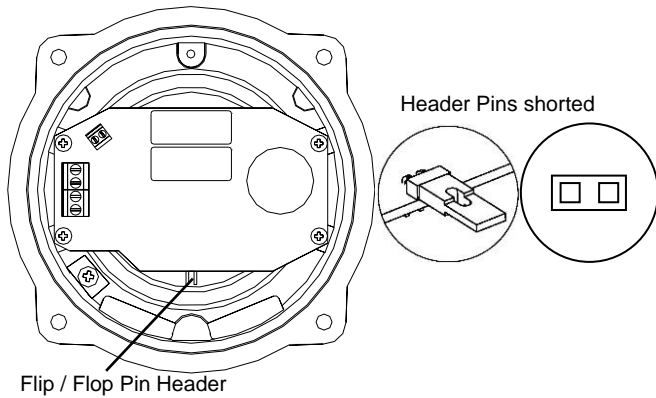

16) Interchangeable & Spare Parts



Warning – Hot surfaces. External surfaces and internal components may be hot after operation, take care when handling the equipment.

The beacon cover is interchangeable, contact E2S Ltd for a replacement cover available in various colours.

To change the cover, unscrew the M5 socket head screws and remove the M5 screws, M5 spring & flat washers.

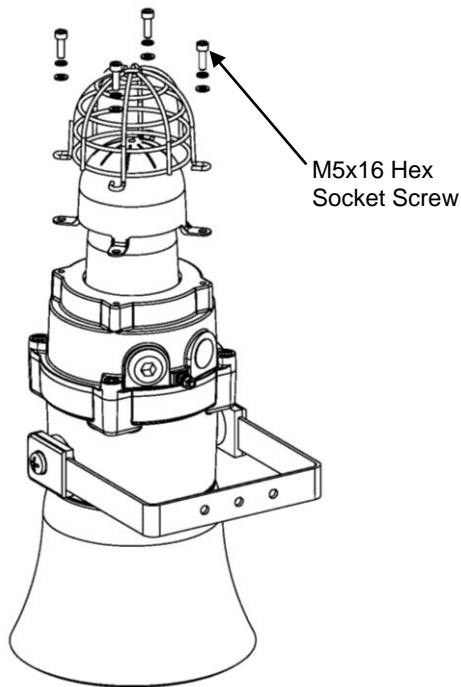

Fig. 11 Removal of cover

Remove the guard and replace the old cover with the new cover.

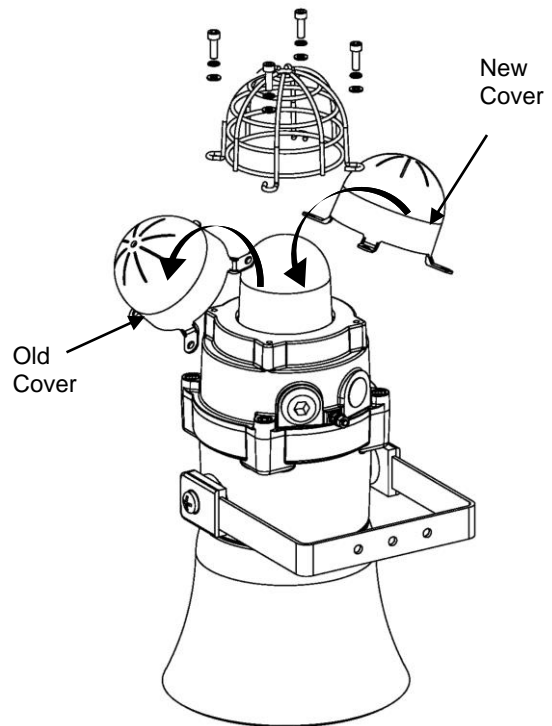

Fig. 12 Changing of cover

Fit the guard back on to the cover and casting, align the holes of the guard, cover and casting. To reattach the cover, the fixings **MUST** be in the order shown in figure 12.

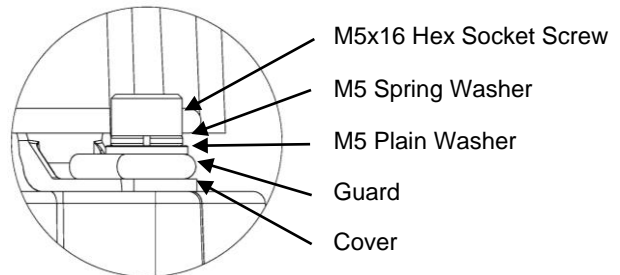

Fig. 13 Cover and Guard Fixtures

17) Maintenance, Overhaul & Repair

Maintenance, repair and overhaul of the equipment should only be carried out by suitably qualified personnel in accordance with the current relevant standards:

- EN60079-19 Explosive atmospheres - Equipment repair, overhaul and reclamation
- IEC60079-19
- EN 60079-17 Explosive atmospheres - Electrical installations inspection and maintenance
- IEC60079-17

To avoid a possible ELECTROSTATIC CHARGE the unit must only be cleaned with a damp cloth.

Units must not be opened while an explosive atmosphere is present.

If opening the unit during maintenance operations a clean environment must be maintained and any dust layer removed prior to opening the unit.

Flameproof threaded joints and cemented joints are not intended to be repaired.

Tone Selection		DIP Switch Settings					Stage Selection	
Stage 1	Frequency Description	1	2	3	4	5	Stage 2	Stage 3
1	Continuous 1000Hz Toxic Gas Alarm	0	0	0	0	0	Tone 31	Tone 11
2	Alternating 800/1000Hz at 0.25s intervals	1	0	0	0	0	Tone 17	Tone 5
3	Slow Whoop 500/1200Hz at 0.3Hz with 0.5s gap repeated	0	1	0	0	0	Tone 2	Tone 5
4	Sweeping 800/1000 at 1Hz	1	1	0	0	0	Tone 6	Tone 5
5	Continuous at 2400Hz	0	0	1	0	0	Tone 3	Tone 27
6	Sweeping 2400/2900Hz at 7Hz	1	0	1	0	0	Tone 7	Tone 5
7	Sweeping 2400/2900Hz at 1Hz	0	1	1	0	0	Tone 10	Tone 5
8	Siren 500/1200/500Hz at 0.3Hz	1	1	1	0	0	Tone 2	Tone 5
9	Sawtooth 1200/500Hz at 1Hz	0	0	0	1	0	Tone 15	Tone 2
10	Alternating 2400/2900Hz at 2Hz	1	0	0	1	0	Tone 7	Tone 5
11	Intermittent 1000Hz at 0.5Hz General alarm	0	1	0	1	0	Tone 31	Tone 1
12	Alternating 800/1000Hz at 0.875Hz	1	1	0	1	0	Tone 4	Tone 5
13	Intermittent 2400Hz at 1Hz	0	0	1	1	0	Tone 15	Tone 5
14	Intermittent 800Hz 0.25s on 1s off	1	0	1	1	0	Tone 4	Tone 5
15	Continuous at 800Hz	0	1	1	1	0	Tone 2	Tone 5
16	Intermittent 660Hz 150mS on, 150mS off	1	1	1	1	0	Tone 18	Tone 5
17	Alternating 544Hz (100mS)/440Hz(400mS)	0	0	0	0	1	Tone 2	Tone 27
18	Intermittent 660Hz 1.8s on, 1.8s off	1	0	0	0	1	Tone 2	Tone 5
19	1400Hz to 1600Hz sweep up over 1s - 1600Hz to 1400Hz sweep down over 0.5s	0	1	0	0	1	Tone 2	Tone 5
20	Continuous 660Hz	1	1	0	0	1	Tone 2	Tone 5
21	Alternating 554/440Hz at 1Hz	0	0	1	0	1	Tone 2	Tone 5
22	Intermittent 554Hz at 0.875Hz	1	0	1	0	1	Tone 2	Tone 5
23	800Hz pulsing at 2Hz	0	1	1	0	1	Tone 6	Tone 5
24	Sweeping 800/1000Hz at 50Hz	1	1	1	0	1	Tone 29	Tone 5
25	Sweeping 2400/2900Hz at 50Hz	0	0	0	1	1	Tone 29	Tone 5
26	Simulated bell sound	1	0	0	1	1	Tone 2	Tone 1
27	Continuous 554Hz	0	1	0	1	1	Tone 26	Tone 5
28	Continuous 440Hz	1	1	0	1	1	Tone 2	Tone 5
29	Sweeping 800/1000Hz at 7Hz	0	0	1	1	1	Tone 7	Tone 5
30	420Hz repeating 0.625s on, 0.625s off Australian alert signal	1	0	1	1	1	Tone 32	Tone 5
31	1200/500Hz at 1 Hz Prepare to Abandon Platform	0	1	1	1	1	Tone 11	Tone 1
32	Sweeping 500/1200Hz 3.75s on, 0.25s off 15Hz	1	1	1	1	1	Tone 26	Tone 1



SCATTERGOOD & JOHNSON LTD

ELECTRICAL ENGINEERING & FLUID CONTROL DISTRIBUTORS

Est.1899

At Scattergood & Johnson Ltd, we pride ourselves on being a technical distributor to specialist industries.

Working with a range of quality product suppliers across a number of specialist markets, we are not your average 'box shifter' - we are your technical and supply chain partner.

We fully support every product we sell - for free! Our internal team and external sales engineers can answer any product or application question, no matter the complexity.

Backing up this technical ability is a range of 50,000+ products available from stock for nationwide next day delivery (same day if required!), or you can collect what you need from any of our trade counters around the UK.

Select your specialist interest below to learn more about how we can help.



Online, In Branch and On the Road - Scattergood & Johnson Ltd, there when you need us.

www.scatts.co.uk