

1-32-025 / Non-sparking signals



D2xS1 Alarm Horn Sounder

The D2xS1 is a high output, 116dB(A) alarm horn sounder. Low current consumption and high SPL in a compact robust Type 4/4X, IP66 enclosure ensure the D2xS1 is suitable for all haz loc fire alarm system and general signalling applications.

The corrosion proof, marine grade aluminium die cast enclosure is chromated and powder coated providing resilience in the harshest of environments. One device, globally certified: ATEX, IECEx Zone 2 & 22; NEC/CEC CI D2 and CII D2; NEC CI Zone 2 and Zone 22; CEC Zone 2 & 22 and CII D2. UL, cUL & ULC approved 24Vdc version for public mode fire alarm use.

Features

- High output, up to 116dB(A)
- 4 remotely selectable alarm stages/channels
- Choice of 64 alarm tone frequencies
- Automatic synchronisation on multi-sounder system
- UL464 Fire Alarm
- CAN/ULC-S525 Fire Alarm

Approvals

- UL File ref: E230764
- IECEx cert: IECEx ULD 14.0004X
- ATEX cert: DEMKO 14 ATEX 4786493904X
- CSFM listing: 7136-2279:0503

Coding

- NEC / CEC: Class I Div 2 ABCD T3C Ta -40°C to +70°C
Class I Div 2 ABCD T4 Ta -40°C to +65°C, T4A Ta -40°C to +50°C
Class II Div 2 FG T5 Ta -40°C to +50°C, T6 Ta -40°C to +45°C
Class III Div 1&2 Ta -40°C to +50°C
- NEC: Class I Zone 2 AEx nA IIC T4 Gc (Ta -40°C to +50°C)
Zone 22 AEx tc IIIC 90°C Dc (Ta -40°C to +50°C)
- CEC: Class I Zone 2 Ex nA IIC T4A Gc X (Ta -40°C to +50°C)
Zone 22 Ex tc IIIC 90°C Dc (Ta -40°C to +50°C)
Class II Div 2 EFG T5 Ta -40°C to +50°C
- IECEx & ATEX: II 3G Ex nA IIC T4 Gc (Ta -40°C to +50°C)
II 3D Ex tc IIIC 90°C Dc (Ta -40°C to +50°C)



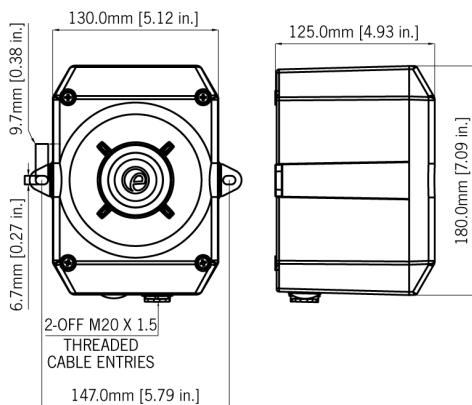

Specification

Maximum output:	116dB(A) @ 1 metre [107dB(A) @ 10ft/3m]
Nominal output:	112dB(A) @ 1m +/- 3dB - Tone 2 [103dB(A) @ 10ft/3m]
No. of tones:	64 (UK00A / PFEER compliant)
No. of stages:	4
Volume control:	Adjustable -12dB(A) [Tone 2]
Effective range:	125m/410ft @ 1KHz
Voltages DC:	24V dc (10-30V dc); 48V dc (38-58V dc)
Voltages AC:	115V ac 50/60Hz; 230V ac 50/60Hz
Stage switching:	DC units: negative or positive AC units: common supply line
Ingress protection:	EN60529: IP66 UL50E / NEMA250: 4 / 4X / 3R / 13
Housing material:	Marine grade aluminium Al Si12 Cu
Colour:	Red (RAL3000), Grey (RAL7038)
Cable entries:	2 x M20 x 1.5mm threaded gland entries Adaptors available to 1/2"NPT, 3/4"NPT and M25
Terminals:	0.5 - 2.5mm ² (20-14 AWG)
Grounding stud:	M5
Operating temp:	-40 to +70°C [-40° to +158°F] - Class I Div 2 -40 to +50°C [-40° to +122°F] - All other markings
Relative humidity:	95%
Weight:	DC: 2.48kg/4.96lbs AC:2.73kg/5.46lbs

Part Codes

Version:	Part code:	Description:
Product type:	D2xS1	Haz Loc alarm horn sounder
Voltage:	DC024 DC048 AC115 AC230	24V dc - UL/cUL Fire Alarm 48V dc 115V ac 230V ac
Cable Entry Type: [e]	A B C D E F G	2 x M20x1.5mm 2 x 1/2" NPT - adaptors 2 x 3/4" NPT - adaptors 2 x M25x1.5mm - adaptors 1 x 1/2" NPT - adaptor 1 x 3/4" NPT - adaptor 1 x M25x1.5mm - adaptor
Adaptor/Stopping plug material: [m]	B N S	Brass Nickel Plated Stainless Steel
Equipment tag: [s]	1 3	No equip. tag With equip. tag
Product version: [v]	A1	UL, cUL, ULC, IECEx & ATEX
Enclosure colour: [x]	R G	Red RAL3000 Grey RAL7038
Accessories:	SP65-0001-A2 SP65-0001-A4 SP65-0002-A2 SP65-0002-A4	Pole Mount Bracket Kit 2" St/St A2 (304) Pole Mount Bracket Kit 2" St/St A4 (316) Sunshade - St/St A2 (304) Sunshade - St/St A4 (316)

Alarm Sounder

Version:	In Rush:	Voltage:	Current:
24V dc	1.8A	10-30V dc	313mA [at nominal voltage]
48V dc		38-58V dc	181mA [at nominal voltage]
115V ac 50/60Hz		+/-10%	90mA
230V ac 50/60Hz		+/-10%	52mA

Tone table**S 1 Description**

T 1	1000 Continuous - PFEER Toxic Gas
T 2	1200/500 @ 1Hz Sweeping - DIN / PFEER P.T.A.P.
T 3	1000 @ 0.5Hz (1s on, 1s off) Intermittent - P...
T 4	1.4KH-1.6KHz 1s, 1.6KHz-1.4KHz 0.5s - NF C 48...
T 5	544(100mS)/440 (400mS) - NF S 32-001
T 6	1500/500 - (0.5s on , 0.5s off) x3 + 1s gap -...
T 7	500-1500Hz Sweeping 2 sec on 1 sec off - AS4428
T 8	500/1200Hz @ 0.26Hz(3.3s on, 0.5s off) - NEN ...
T 9	1000 (1s on, 1s off)x7 + (7s on, 1s off) - IM...
T 10	1000 (1s on, 1s off)x7 + (7s on, 1s off) - IM...
T 11	420(0.5s on, 0.5s off)x3 + 1s gap - ISO 8201 ...
T 12	1000(0.5s on, 0.5s off)x3 + 1s gap - ISO 8201...
T 13	422/775 - (0.85 on, 0.5 off) x3 + 1s gap - ...
T 14	1000/2000 @ 1Hz - Singapore
T 15	300 Continuous
T 16	440 Continuous
T 17	470 Continuous
T 18	500 Continuous - IMO code 2 (Low)
T 19	554 Continuous
T 20	660 Continuous
T 21	800 Continuous - IMO code 2 (High)
T 22	1200 Continuous
T 23	2000 Continuous
T 24	2400 Continuous
T 25	440 @ 0.83Hz (0.60s on, 0.60s off) Intermittent
T 26	470 @ 0.9Hz (0.55s on, 0.55s off) Intermittent
T 27	470 @ 5Hz (0.10s on, 0.10s off) Intermittent
T 28	544 @ 1.14Hz (0.43s on, 0.44s off) Intermittent
T 29	655 @ 0.875Hz (0.57s on, 0.57s off) Intermittent
T 30	660 @ 0.28Hz (1.80s on, 1.80s off) Intermittent
T 31	660 @ 3.3Hz (0.15s on, 0.15s off) Intermittent
T 32	745 @ 1Hz (0.50s on, 0.50s off) Intermittent

S 1 Description

T 33	800 (0.25s on, 1.00s off) Intermittent
T 34	800 @ 2Hz (0.25s on, 0.25s off) - IMO code 3....
T 35	1000 @ 1Hz (0.50s on, 0.50s off) Intermittent
T 36	2400 @ 1Hz (0.50s on, 0.50s off) Intermittent
T 37	2900 @ 5Hz (0.10s on, 0.10s off) Intermittent
T 38	363/518 @ 1Hz (0.50s / 0.50s) Alternating
T 39	450/500 @ 2Hz (0.25s / 0.25s) Alternating
T 40	554/440 @ 1Hz (0.50s / 0.50s) Alternating
T 41	554/440 @ 0.65Hz (0.76s / 0.76s) Alternating
T 42	561/760 @ 0.83Hz (0.60s / 0.60s) Alternating
T 43	780/600 @ 0.96Hz (0.52s / 0.52s) Alternating
T 44	800/1000 @ 2Hz (0.25s / 0.25s) Alternating
T 45	970/800 @ 2Hz (0.25s / 0.25s) Alternating
T 46	800/1000 @ 0.875Hz (0.57s / 0.57s) Alternating
T 47	2400/2900 @ 2Hz (0.25s / 0.25s) Alternating
T 48	500/1200 @ 0.3Hz (1.67s / 1.67s) Sweeping
T 49	560/1055 @ 0.18Hz (2.73s / 2.73s) Sweeping
T 50	560/1055 @ 3.3Hz (0.15s / 0.15s) Sweeping
T 51	600/1250 @ 0.125Hz (4s / 4s) Sweeping
T 52	660/1200 @ 1Hz (0.50s / 0.50s) Sweeping
T 53	800/1000 @ 1Hz (0.50s / 0.50s) Sweeping
T 54	800/1000 @ 7Hz (0.07s / 0.07s) Sweeping
T 55	800/1000 @ 50Hz (0.01s / 0.01s) Sweeping
T 56	2400/2900 @ 7Hz (0.07s / 0.07s) Sweeping
T 57	2400/2900 @ 1Hz (0.50s / 0.50s) Sweeping
T 58	2400/2900 @ 50Hz (0.01s / 0.01s) Sweeping
T 59	2500/3000 @ 2Hz (0.25s / 0.25s) Sweeping
T 60	2500/3000 @ 7.7Hz (0.65s / 0.65s) Sweeping
T 61	800Hz Motor Siren
T 62	1200Hz Motor Siren
T 63	2400Hz Motor Siren
T 64	Simulated Bell



SCATTERGOOD & JOHNSON LTD

ELECTRICAL ENGINEERING & FLUID CONTROL DISTRIBUTORS

Est.1899

At Scattergood & Johnson Ltd, we pride ourselves on being a technical distributor to specialist industries.

Working with a range of quality product suppliers across a number of specialist markets, we are not your average 'box shifter' - we are your technical and supply chain partner.

We fully support every product we sell - for free! Our internal team and external sales engineers can answer any product or application question, no matter the complexity.

Backing up this technical ability is a range of 50,000+ products available from stock for nationwide next day delivery (same day if required!), or you can collect what you need from any of our trade counters around the UK.

Select your specialist interest below to learn more about how we can help.



Online, In Branch and On the Road - Scattergood & Johnson Ltd, there when you need us.

www.scatts.co.uk