

INSTRUCTION MANUAL

E2xBL2 LED Beacons

For use in Hazardous Locations

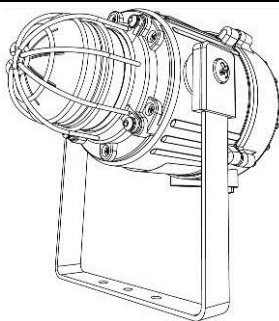

1) Warnings



- DO NOT OPEN WHEN AN EXPLOSIVE ATMOSPHERE IS PRESENT
- DO NOT OPEN WHEN ENERGISED
- POTENTIAL ELECTROSTATIC CHARGING HAZARD - CLEAN ONLY WITH A DAMP CLOTH
- HIGH VOLTAGE SHOCK HAZARD. WAIT 5 MINUTES AFTER REMOVING POWER BEFORE OPENING THE ENCLOSURE

Avertissement:

- NE PAS OUVRIR UN PRESENCE D'ATMOSPHERE EXPLOSIVE
- NE PAS OUVRIR ENERGIE
- DANGER POTENTIEL CHARGE ÉLECTROSTATIQUE - NETTOYER UNIQUEMENT AVEC UN CHIFFON HUMIDE
- HAUT TENSION, RISK DE CHOC. ATTENDEZ 5 MINUTES APRES AVOIR DEBRANCHE L'ALIMENTATION AVANT D'OUVRIR LA BOITIER

2) Rating & Marking Information

2.1 ATEX / IECEx certification

The E2xBL2 LED beacon complies with the following standards:

EN60079-0:2012+A11:2013 / IEC60079-0: ed. 6.0 (2011-06)
EN60079-15:2010 / IEC60079-15: ed. 4.0 (2010-01)
EN60079-31:2014 / IEC60079-31:2013 ed. 2.0 (2013-11)

Certificate No. DEMKO 06ATEX 0421554X
IECEx ULD 14.0012X

The E2xBL2 LED beacon is rated as follows:



II 3G Ex nA IIC Gc T4 Ta -20°C to +55°C
II 3D Ex tb IIIC Dc T85°C Ta -20°C to +55°C

CE Marking



Zones, Gas / Dust Groups and Temperature Classification

When connected to an approved system the E2XBL2 LED beacon may be installed in:

Zone 2 explosive gas air mixture not likely to occur in normal operation, and if it does, it will only exist for a short time.

Zone 22 explosive dust air mixture not likely to occur in normal operation, and if it does, it will only exist for a short time.

May be used with gases in groups:

Group IIA	propane
Group IIB	ethylene
Group IIC	hydrogen / acetylene

Having a temperature classification (for Gas applications) of:

T1	450°C
T2	300°C
T3	200°C
T4	135°C

May be used with Dust types:

Group IIIA	combustible flyings
Group IIIB	non-conductive dust
Group IIIC	conductive dust

Maximum Surface Temperature for Dust Applications:

85°C

Installation must be carried out in compliance with the latest issue of the following standards:

EN60079-14 / IEC60079-14: Explosive atmospheres - Electrical installations design, selection and erection
EN60079-10-1 / IEC60079-10-1: Explosive atmospheres - Classification of areas. Explosive gas atmospheres
EN60079-10-2 / IEC60079-10-2: Explosive atmospheres - Classification of areas. Explosive dust atmospheres

2.2 NEC Class / Zone ratings US

The E2xBL2 LED beacon complies with the following standards:

UL 60079-0-2013
UL 60079-15-2013
UL 60079-31-2015

The E2xBL2 LED beacon is rated as follows:

Class I Zone 2 AEx nA IIC Gc T4 Ta -20°C to +55°C
AEx tb IIIC Dc T85°C Ta -20°C to +55°C

Installation must be carried out in compliance with the National Electric Code.

2.3 CEC Class / Zone ratings Canada

The E2xBL2 LED beacon complies with the following standards:

CAN/CSA C22.2 No. 60079-0:2015
CAN/CSA C22.2 No. 60079-15:2016
CAN/CSA C22.2 No. 60079-31:2015

The E2xBL2 LED beacon is rated as follows:

Ex nA IIC Gc T4 Ta -20°C to +55°C
Ex nA IIC Gc T4A Ta -20°C to +40°C
Ex tb IIIC Dc T85°C Ta -20°C to +55°C

Installation must be carried out in compliance with the Canadian Electric Code

2.4 NEC & CEC Class / Division Ratings for US / Canada

The E2xBL2 LED beacon complies with the following standards:

ANSI/ISA 12.12.01-2015
CSA C22.2 No. 213-16

The E2xBL2 LED beacon is rated as follows:

Class I, Div 2, ABCD T4A Ta -20°C to +55°C
Class II, Div 2, FG T6 Ta -20°C to +55°C
Class III, Div 1&2 Ta -20°C to +55°C

Installation must be carried out in compliance with the National Electric Code / Canadian Electric Code

2.5 Ingress Protection Ratings

The product is rated for ingress Protection as follows:

IP rating per EN60079-0: IP64
IP rating per EN60529: IP66
Type rating per UL50E / NEMA250: 4 / 4X / 13

To maintain the ingress protection rating, the two off cable entries must be fitted with suitably rated, certified cable entry and/or blanking devices during installation.

2.6 Electrical Ratings

Model No.	Voltage	Current
E2xBL2DC024	18-54Vdc	346mA
E2xBL2AC115	115-120Vac 50/60Hz	102.4mA
E2xBL2AC230	220-230Vac 50/60Hz	49.4mA

It is important that a suitable power supply is used to run the equipment. The power supply selected must have the necessary capacity to provide the input current to all the units.

The input current will vary according to the voltage input level. The current levels shown above are for the worst-case input voltage and flash setting resulting in max. current.

3) Special Conditions of Use

When used for a Group III application, the surface of the enclosure may store electrostatic charge and become a source of ignition in applications with a low relative humidity <~30% relative humidity where the surface is relatively free of surface contamination such as dirt, dust, or oil.

Guidance on protection against the risk of ignition due to electrostatic discharge can be found in EN TR50404 and IEC TR60079-32.

End user shall adhere to the manufacturer's installation and instruction when performing housekeeping to avoid the potential for hazardous electrostatic charges during cleaning, by using a damp cloth.

To maintain the ingress protection rating and mode of protection, the cable entries must be fitted with suitably rated, certified cable entry and/or blanking devices during installation. If conduit is used for installation, seal conduit within 18 inches from the enclosure.

The equipment incorporates metal parts isolated from earth, having capacitance values exceeding the limits permitted in the standards of certification. Mounting bracket – 10.33pF; Lens guard – 12.33pF.

4) Location and Mounting

The location of the beacon should be made with due regard to the area over which the warning signal must be audible. They should only be fixed to services that can carry the weight of the unit.

The E2x beacon should be secured to any flat surface using the three 7mm fixing holes on the stainless steel U shaped mounting bracket. See Figure 1. The required angle can be achieved by loosening the two large bracket screws on the side of the unit, which allow adjustment of the beacon in steps of 18°. On completion of the installation the two large bracket adjustment screws on the side of the unit must be fully tightened to ensure that the unit cannot move in service.

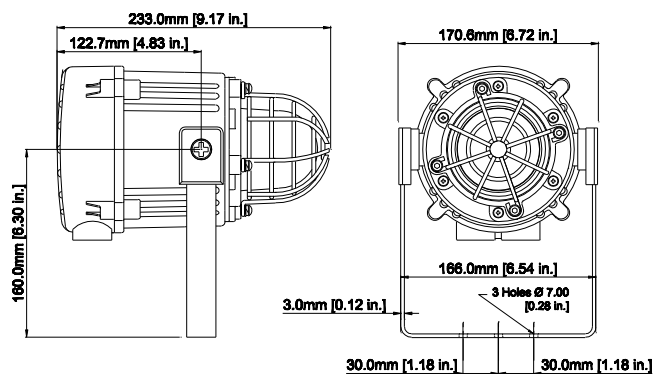

Fig. 1 Fixing Location for Beacon

The dual entries can be ordered with one of the following options:

- 2-off M20 x 1.5 thread
- 2-off ½" NPT thread
- 1-off M20 x 1.5 & 1-off ½" NPT thread

To maintain the ingress protection rating and mode of protection, the cable entries must be fitted with suitably rated, certified cable entry and/or blanking devices during installation. If conduit is used for installation, seal conduit within 18 inches from the enclosure.

For ambient temperatures over +40°C the cable entry temperature may exceed +70°C or the cable branching temperature may exceed +80°C. Therefore suitable heat resisting cables and cable glands must be used as per table below

Ambient Temp.	40°C	45°C	50°C	55°C
Min. Rating of cables and cable glands	90°C	95°C	100°C	105°C

If a high IP (Ingress Protection) rating is required then a suitable sealing washer must be fitted under the cable glands or blanking plugs.

For use in explosive dust atmospheres, a minimum ingress protection rating of IP6X must be maintained.

For use in explosive gas atmospheres, a minimum ingress protection rating of IP54 must be maintained.

7) Cable Connections

Electrical connections are to be made into the terminal blocks on the PCBA located in the enclosure. See section 5 of this manual for access to the enclosure.

Wires having a cross sectional area between 0.5 mm² to 2.5mm² can be connected to each terminal way. If an input and output wire is required the 2-off Live/Neutral or +/- terminals can be used. If fitting 2-off wires to one terminal way the sum of the 2-off wires must be a maximum cross sectional area of 2.5mm². Strip wires to 8mm. Wires may also be fitted using ferrules. Terminal screws need to be tightened down with a tightening torque of 0.56 Nm / 5 Lb-in. When connecting wires to the terminals great care should be taken to dress the wires so that when the cover is inserted into the chamber the wires do not exert excess pressure on the terminal blocks. This is particularly important when using cables with large cross sectional areas such as 2.5mm².

5) Access to the Enclosure



Warning – High voltage may be present, risk of electric shock. DO NOT open when energised, disconnect power before opening.



Warning – Hot surfaces. External surfaces and internal components may be hot after operation, take care when handling the equipment.

To access the enclosure, remove the four M4 posi pan head screws, M4 spring and plain washers and withdraw the cover.

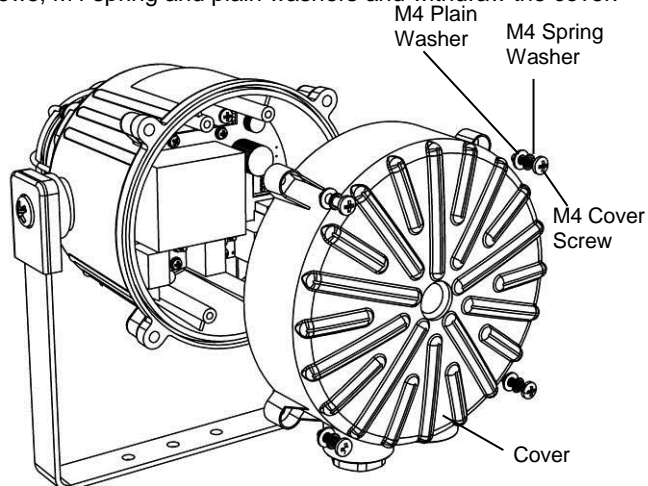

(Appropriate cable entry devices to be customer supplied)

Fig. 2 Accessing the Enclosure.

To replace cover, check that the 'O' ring seal is in place. Carefully push the cover in place. Insert and tighten down M4 screws, spring and plain washers in the order shown above and tighten down.

6) Selection of Cable, Cable Glands, Blanking Elements & Adapters

When selecting the cable size, consideration must be given to the input current that each unit draws (see Table 1), the number of sounders on the line and the length of the cable runs. The cable size selected must have the necessary capacity to provide the input current to all of the sounders connected to the line.

8) AC Wiring

3-off 2-way terminal blocks are provided on the AC beacon for power. There are 2-off Live, 2-off Neutral and 2-off Earth terminals in total.

8.1 Wiring Diagrams

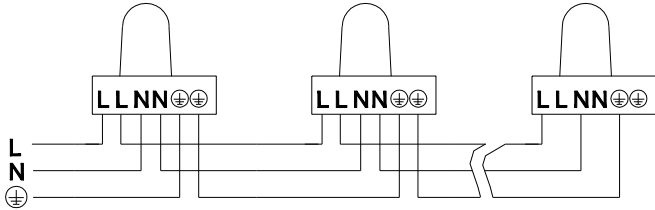

Fig 3. E2XBL2 AC Simplified Block Diagram

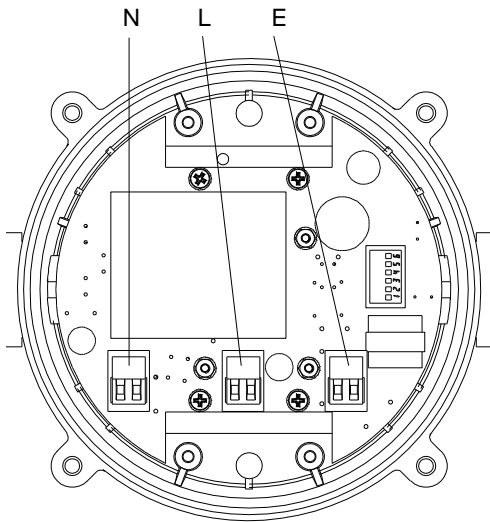

Fig. 4 E2XBL2 AC Terminals

9) DC Wiring

3-off 2-way terminal blocks are provided on the AC beacon for power. There are 2-off +ve, 2-off -ve, 1-off Stage 2 and 1-off stage 3 terminals in total.

9.1 Wiring Diagrams

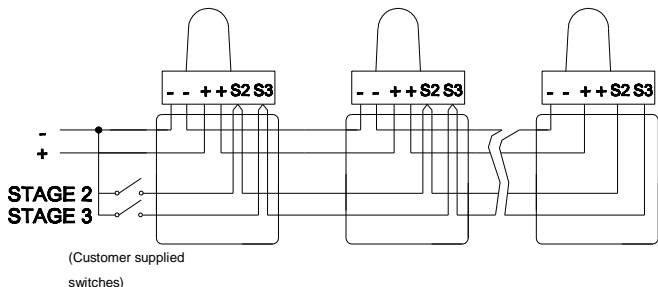

Fig. 5 E2XBL2 DC Simplified Block Diagram

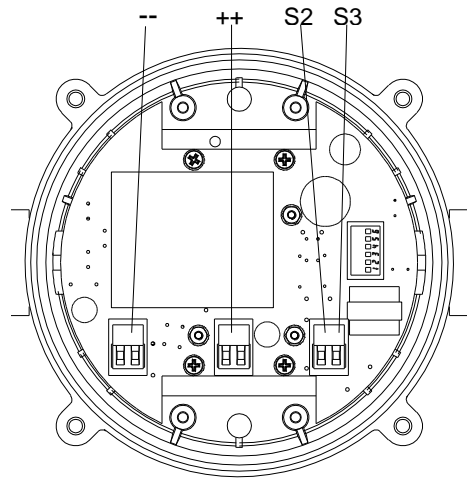

Fig. 6 E2XBL2 DC Terminals

9.2 Line Monitoring

On E2xBL2 DC units, DC reverse line monitoring can be used if required. All DC beacons have a blocking diode fitted in their supply input lines. An end of line monitoring resistor can be connected across the +ve and -ve terminals. If an end of line resistor is used it must have the following values:

24V DC Beacons

Minimum resistance 3K9 Ohms	Minimum Power 0.5W
Minimum resistance 1K Ohms	Minimum Power 2.0W

48V DC Beacons

Minimum resistance 15K Ohms	Minimum Power 0.5W
Minimum resistance 3K9 Ohms	Minimum Power 2.0W

The resistor must be connected directly across the +ve and -ve terminals as shown in the following drawing. Form the resistor legs as shown in Fig. 8a, remove the +ve and -ve terminal plugs and fit the resistor across the two terminal plugs before refitting them to the PCBA as shown in Fig. 8b. A spacing of at least 1/16" (1.58mm) must be provided through air and over surfaces between uninsulated live parts.

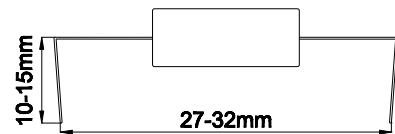

Fig. 8a End of Line Resistor Forming

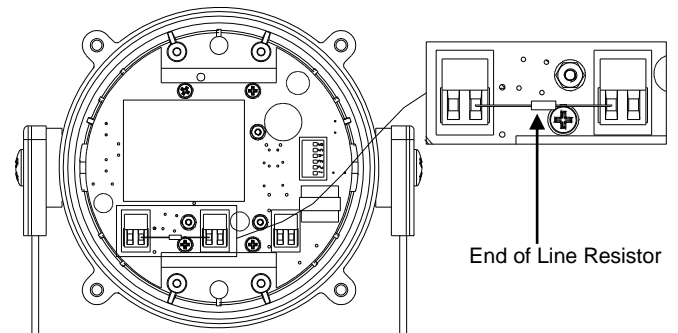

Fig. 8b End of Line Resistor Placement

10) Settings

13.1 Flash Rate Setting



Warning – high-intensity light source. Avoid looking directly at the light source for extended periods of time.

The E2xBL2 beacons can produce different flash patterns as shown in Table 1. The flash patterns are selected by operation of the flash setting DIP switch on the PCB, Fig 6.

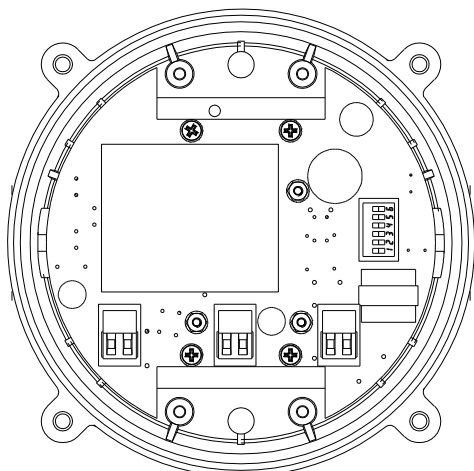

Fig. 9: DIP Switch Location

Switch Setting	S1 Mode	S2 Mode	S3 Mode
(123456)	(DC & AC)	(DC Only)	(DC Only)
000000	Steady High Power	Flashing 1Hz	Flashing Triple Strike
000001	Steady Low Power	Flashing 1Hz	Flashing Triple Strike
100000	Flashing 1Hz	Flashing Double Strike	Flashing Triple Strike
101000	Flashing 1.5Hz	Flashing 2Hz	Flashing Double Strike
010000	Flashing 2Hz	Flashing Triple Strike	Flashing Triple Strike
110000	Flashing Double Strike	Steady High Power	Flashing Triple Strike
001000	Flashing Triple Strike	Flashing 2Hz	Flashing Double Strike

Table 1: Switch Positions for Flash Patterns

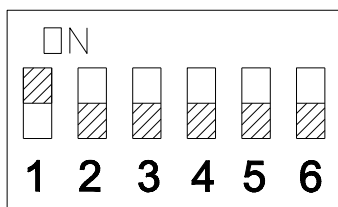

Fig. 10 Dip Switch

1=ON; 0=OFF

Example shown: 100000 = Flashing 1Hz (Default setting)

11) Interchangeable & Spare Parts



Warning – Hot surfaces. External surfaces and internal components may be hot after operation, take care when handling the equipment.

The Beacon lens cover is interchangeable, contact E2S Ltd for a replacement lens cover available in various colours.

To change the lens cover, unscrew the 4-off M5 Cap screws, spring and flat washers using a 4mm Allen Key. Remove the wire guard and replace the old cover with the new cover.

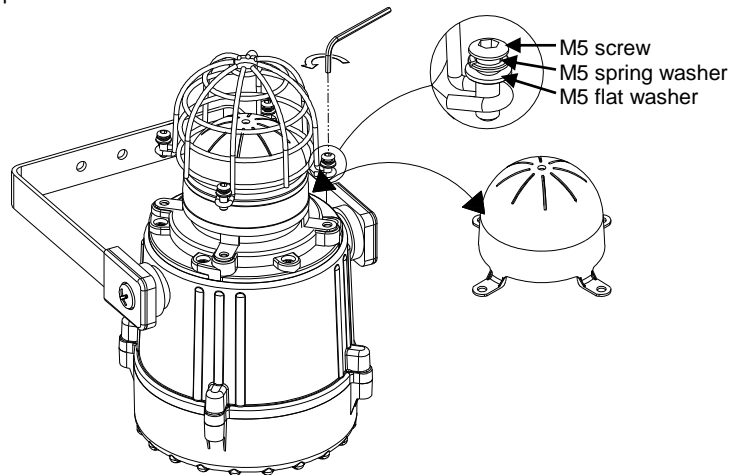

Fig. 9 Replacement of beacon lens cover

Fit the wire guard back onto the housing, over the new lens cover aligning the fixing holes of the guard, lens cover and housing. Refit the fixings to hold into place, the fixings MUST be fitted in the order shown above.

12) Maintenance, Overhaul & Repair

Maintenance, repair and overhaul of the equipment should only be carried out by suitably qualified personnel in accordance with the current relevant standards:

- EN60079-19 Explosive atmospheres - Equipment repair, overhaul and reclamation
- IEC60079-19 Explosive atmospheres - Electrical installations inspection and maintenance
- EN 60079-17 Explosive atmospheres - Electrical installations inspection and maintenance
- IEC60079-17 Explosive atmospheres - Electrical installations inspection and maintenance

To avoid a possible ELECTROSTATIC CHARGE the unit must only be cleaned with a damp cloth.

Units must not be opened while an explosive atmosphere is present.

If opening the unit during maintenance operations a clean environment must be maintained and any dust layer removed prior to opening the unit.

EU Declaration of Conformity



Manufacturer: European Safety Systems Ltd.
Impress House, Mansell Road, Acton
London, W3 7QH, United Kingdom

Equipment Type: E2xS1, E2xS2
E2xB05, E2xB10, E2xBL2
E2xC1X05, E2xC1LD2,
E2xL15, E2xL25

Directive 2014/34/EU: Equipment and Protective Systems for use in Potentially Explosive Atmospheres (ATEX)

Notified Body for EU type Examination (Module B):	UL International Demko A/S Notified Body No.: 0539 Borupvang 5A, 2750 Ballerup, Denmark
EU-type Examination Certificate (Module B):	DEMKO 06 ATEX 0421554X
Notified Body for Quality Assurance Notification / Conformity to EU-type based on quality assurance of the production process (Module D):	Sira Certification Service Notified Body No.: 0518 Rake Lane, Eccleston, Chester CH4 9JN, UK
Quality Assurance Notification (Module D):	SIRA 05 ATEX M342
Provisions fulfilled by the equipment:	II 3G Ex na IIC T4/T3/T2 Gc II 3D Ex tc IIIC 85°C...120°C Dc IP6X Dust Protection to EN60079-0 / EN60079-31
Standards applied:	EN60079-0:2012 + A11:2013 EN60079-15:2010 EN60079-31:2014

Directive 2014/30/EU: Electromagnetic Compatibility Directive (EMC)

Standards applied:	EN 61000-6-1:2007 EN 61000-6-2:2005 EN 61000-6-3:2007 / A1:2011 / AC: 2012 EN 61000-6-4:2007 / A1: 2011
--------------------	--

Directive 2011/65/EU: Restriction of the use of certain hazardous substances in electrical and electronic equipment (RoHS)

The product and all the components contained within it are in accordance with the restriction of the use of hazardous substances in electrical and electronic equipment.

Regulation (EC) 1907/2006: Registration, Evaluation, Authorisation and Restriction of Chemicals (REACH)

The product and all the components contained within it are free from substances of very high concern.

Other Standards and Regulations

EN 60529:1992+A2:2013 - Degrees of protection provided by enclosures (IP code) – enclosure rated IP66/IP67

On behalf of European Safety Systems Ltd., I declare that, on the date the equipment accompanied by this declaration is placed on the market, the equipment conforms with all technical and regulatory requirements of the above listed directives, regulations and standards.

This Declaration is issued under the sole responsibility of the manufacturer.

Martin Streetz
Quality Assurance Manager

Document No.: DC-062_Issue_D
Date and Place of Issue: London, 23/06/2017



SCATTERGOOD & JOHNSON LTD

ELECTRICAL ENGINEERING & FLUID CONTROL DISTRIBUTORS

Est.1899

At Scattergood & Johnson Ltd, we pride ourselves on being a technical distributor to specialist industries.

Working with a range of quality product suppliers across a number of specialist markets, we are not your average 'box shifter' - we are your technical and supply chain partner.

We fully support every product we sell - for free! Our internal team and external sales engineers can answer any product or application question, no matter the complexity.

Backing up this technical ability is a range of 50,000+ products available from stock for nationwide next day delivery (same day if required!), or you can collect what you need from any of our trade counters around the UK.

Select your specialist interest below to learn more about how we can help.



Online, In Branch and On the Road - Scattergood & Johnson Ltd, there when you need us.

www.scatts.co.uk