

INSTRUCTION MANUAL

BExCP3A-BG Break Glass Manual Call Point

For use in Flammable Gas and Dust Atmospheres

BExCP3A-BG Manual Call Point – Break Glass

For use in Flammable Gas and
Combustible Dust Atmospheres.

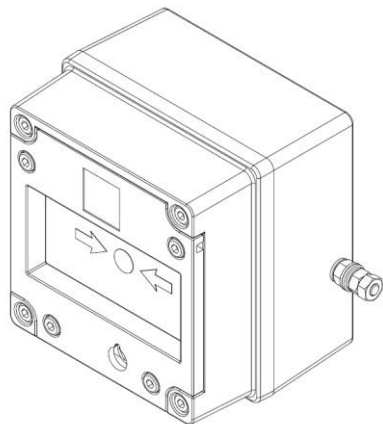

1) Introduction

The BExCP3A-BG is a break glass manual call point which is certified to the European and International Gas and Dust standards. The unit meets the requirements of the ATEX directive 2014/34/EU and IECEx scheme.

The call point can be used in hazardous areas where potentially flammable gas and dust atmospheres may be present.

All units have no monitoring resistors, diodes or zener diodes.

The units are Group II, EPL (equipment protection level) Gb. The equipment is certified 'Ex db eb IIC T6 Gb' and as such may be used in Zones 1 and 2 with flammable gases and vapours with apparatus groups IIA, IIB & IIC and temperature classes T1, T2, T3, T4, T5 and T6.

These units are also Group III, EPL Db. The equipment is certified 'Ex tb IIIC T75°C Db' and as such may be used in Zones 21 and 22 for combustible dusts groups IIIA, IIIB & IIIC.

2) Ratings & Markings

All units have a rating label, which carries the following important information: -

Unit Type No.:
BExCP3A-BG Manual Call Point

Input Voltage:
AC voltage 250V Max Current 5.0A Max
DC voltage 250V Max Current 0.25A Max Resistive Load; Inductive Load 0.03A Max
DC voltage 125V Max Current 0.5A Max Resistive Load; Inductive Load 0.03A Max
DC voltage 75V Max Current 0.75A Max
DC voltage 50V Max Current 1.0A Max
DC voltage 30V Max Current 5.0A Max Resistive Load; Inductive Load 3.0A Max
DC voltage 12V Max Current 5.0A Max

Code:

Ex db eb IIC T6 Gb
Ex tb IIIC T75 °C Db
IP66
-40°C ≤ Ta ≤ +70°C

Certificate No.:
SIRA 09ATEX3286X
IECEx SIR 09.0121X

Epsilon x:  II 2GD

CE Marking
Notified body No.  2813

Year/Serial No. i.e. 20/1CP3ABG000001

**WARNING - DO NOT OPEN WHEN AN
EXPLOSIVE ATMOSPHERE MAY BE PRESENT**

3) Type Approval Standards

The call point has an EC Type examination certificate issued by SIRA and have been approved to the following standards: -

EN60079-0:2018 / IEC60079-0:2017
EN60079-1:2014 / IEC60079-1:2014
EN60079-7:2015 / IEC60079-7:2017
EN60079-18:2015 / IEC60079-18:2014
EN60079-31:2014 / IEC60079-31:2013

The equipment is certified for use in ambient temperatures in the range -40°C to +70°C and shall not be used outside this range.

4) Installation Requirements

Installation of this equipment shall only be carried out by suitably trained personnel in accordance with the applicable code of practice e.g. IEC 60079-14/EN 60079-14

Repair of this equipment shall only be carried out by the manufacturer or in accordance with the applicable code of practice e.g. IEC 60079-19/EN 60079-19.

Refer to certificates SIRA 09ATEX3286X and IECEx SIR 09.0121X for special conditions of safe use.

The certification of this equipment relies on the following materials used in its construction:

Enclosure: Aluminium Pressure Die Cast Body LM6

Through enclosure mechanism: Plastic Nylon Zytel Injection Moulded

Sealing of enclosure and mechanism: O-ring Acrylonitrile-Butadiene Rubber

If the equipment is likely to come into contact with aggressive substances, then it is the responsibility of the user to take suitable precautions that prevent it from being adversely affected, thus ensuring that the type of protection is not compromised.

"Aggressive substances" - e.g. acidic liquids or gases that may attack metals, or solvents that may affect polymeric materials.

"Suitable precautions" - e.g. regular checks as part of routine inspections or establishing from the material's data sheet that it is resistant to specific chemicals.

5) Call Point Location and Mounting

The location of the call point should enable ease of access for operation and testing. The unit should be mounted using the 4 off fixing holes which will accept up to M4 sized fixings.

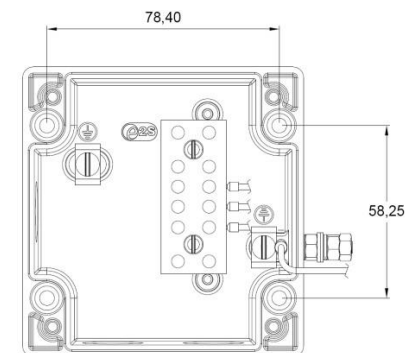

View of base unit showing fixing centres (in mm).

To gain access to the mounting holes in the base the front cover must be removed. This is achieved by removing the 4 off M4 cap head bolts holding on the cover.

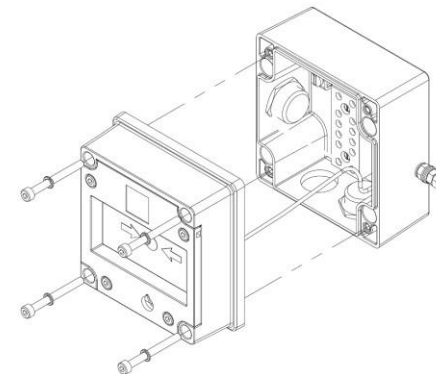

Once the screws are removed the cover will hang down out of the way to gain access to the Ex e terminal block, the internal earth terminal and mounting hole recesses.

6) Earthing

The unit has both internal and external earth terminals. It is recommended that a cable crimp lug is used on the earth wires. The internal earth wire is placed under an earth clamp which will stop the cable twisting. This is secured by an M4 screw and spring washer. The external earth lug should be located between the two M5 washers provided and securely locked down with the M5 spring washer and two locknuts.

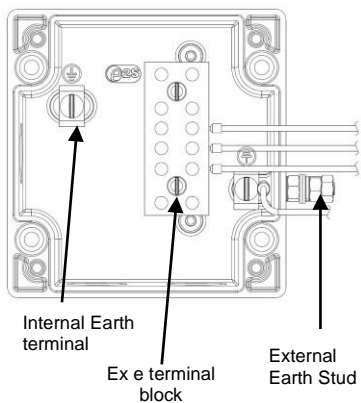

7) Cable connections

There are 3 off cable entry holes suitable for M20x1.5 Ex e approved cable glands or stopping plugs

The unit can be wired in a number of different ways depending whether normally open or normally closed contacts are required. See wiring schematic D150-06-001 for wiring options.

When wiring to Increased Safety terminal enclosures, you are only permitted to connect one wire into each way on the terminal block, unless a pair of wires are crimped into a suitable ferrule. For the six-way terminal block wire sizes allowable are 0.5mm² to 4.0mm²

Leads connected to the terminals shall be insulated for the appropriate voltage and this insulation shall extend to within 1mm of the metal of the terminal throat. They shall only be installed and wired with cable in an ambient temperature of -10°C to +80°C.

All terminal screws, used or unused, shall be tightened down to between 0.5 Nm and 0.7 Nm.

8) Testing unit operation

The break glass unit can be tested without the need to break/replace the frangible glass element. A test key is used to mechanically drop the glass down activating the switch.

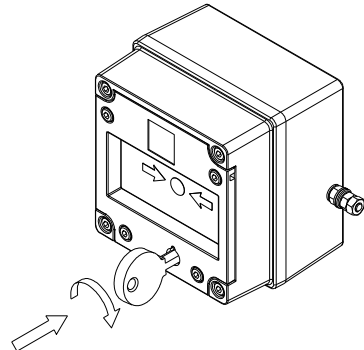

The test key is inserted in the test cam and rotated clockwise by an angle of 60° the glass element will visibly drop down in the viewable window.

The call point switch will now change over its contacts to operate the alarm.

Once testing is complete the unit needs to be reset, the test key is rotated back anticlockwise by an angle of 60° back to its original position. The glass element should now raise up so it is level again in the viewable window.

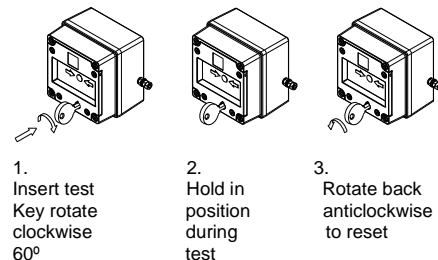

9) Replacement of glass element

If the break glass unit has been operated the broken glass element can be quickly replaced.

The break glass cover plate is removed by unscrewing the 4 off M4 cap head screws attaching it.

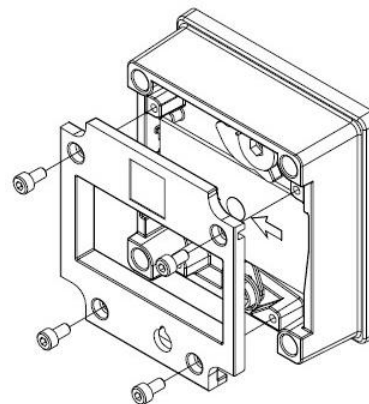

Once the cover is removed the broken glass will be free to be removed, clean out any other fragments of glass carefully.

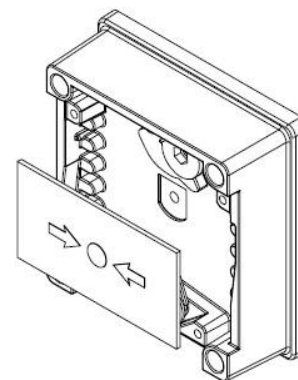

To fit the new glass element rotate the top cam clockwise by an angle of 50° (use a 6mm Allen key) this will then allow the glass to fit back into the pocket it sits in, resting on the pivot point and test cam, release the top cam to rest on the top of the glass element.

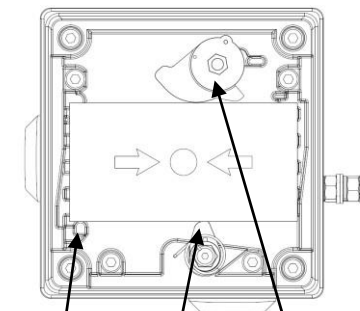

Pivot point Test Cam Top Cam (rotate)

Replace the cover plate and tighten the 4 off M4 cap head screws.

Ensure the glass element is free to move under the cover plate. This can be done by running through the units test operation. See section 8 of this instruction manual.

10) SIL 2 Reliability Data

Reliability and Functional safety IEC/EN61508 which has been assessed and is considered suitable for use in low demand safety function:

- Random Hardware Failures and Systematic Failures (route 2H)
- As an unvoted item (i.e. hardware fault tolerance of 0) at SIL 2

The product was assessed against failure modes:

- Failure to close a contact when the call point is struck with specified force
- Failure to open a contact when the call point is struck with specified force
- Spurious output despite no input

Integrity in respect of failure to close	SIL 2
Total Failure rate	0.133 pmh
"hazardous" failure rate (revealed)	0 pmh
"hazardous" failure rate (unrevealed)	0.1 pmh
"safe" failure rate (revealed)	0.033 pmh
"safe" failure rate (unrevealed)	0
Diagnostic Coverage	99%
System type	A
Hardware Fault Tolerance	0
Safe Failure Fraction	>99%
PFD (hazardous failure)	1.25 x 10 ⁻³
Proof Test Interval	Up to 1 year



SCATTERGOOD & JOHNSON LTD

ELECTRICAL ENGINEERING & FLUID CONTROL DISTRIBUTORS

Est.1899

At Scattergood & Johnson Ltd, we pride ourselves on being a technical distributor to specialist industries.

Working with a range of quality product suppliers across a number of specialist markets, we are not your average 'box shifter' - we are your technical and supply chain partner.

We fully support every product we sell - for free! Our internal team and external sales engineers can answer any product or application question, no matter the complexity.

Backing up this technical ability is a range of 50,000+ products available from stock for nationwide next day delivery (same day if required!), or you can collect what you need from any of our trade counters around the UK.

Select your specialist interest below to learn more about how we can help.



Online, In Branch and On the Road - Scattergood & Johnson Ltd, there when you need us.

www.scatts.co.uk