

INSTRUCTION MANUAL

GNExCP6A-PB Push Button Manual Call Point

For use in Flammable Gas and Dust Atmospheres

GNExCP6A-PB Manual Call Point – Push Button For use in Flammable Gas and Combustible Dust Atmospheres.

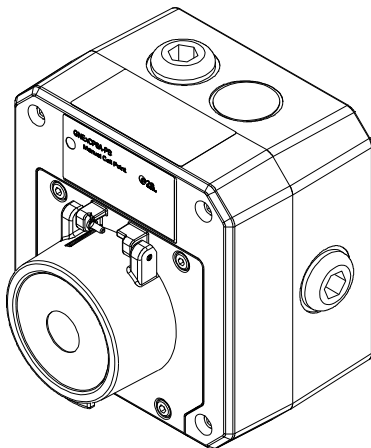

1) Introduction

The GNExCP6A-PB is a push button manual call point which is certified to the European and International Gas and Dust standards. The unit meets the requirements of the ATEX directive 2014/34/EU and IECEx scheme.

The call point can be used in hazardous areas where potentially flammable gas and dust atmospheres may be present.

All units have no monitoring resistors, diodes or zener diodes and are not fitted with an LED indicator.

The units are Group II, EPL (equipment protection level) Gb. The equipment is certified 'Ex db eb IIC T6 Gb' and as such may be used in Zones 1 and 2 with flammable gases and vapours with apparatus groups IIA, IIB & IIC and temperature classes T1, T2, T3, T4, T5 and T6.

These units are also Group III, EPL Db. The equipment is certified 'Ex tb IIIC T75°C Db' and as such may be used in Zones 21 and 22 for combustible dusts groups IIIA, IIIB & IIIC.

2) Ratings & Markings

All units have a rating label, which carries the following important information: -

Unit Type No.:
GNExCP6A-PB Manual Call Point

Input Voltage:
AC voltage 250V Max Current 5.0A Max
DC voltage 250V Max Current 0.25A Max Resistive load : 0.03A Max Inductive load
DC voltage 125V Max Current 0.5A Max Resistive load : 0.03A Max Inductive load
DC voltage 75V Max Current 0.75A Max
DC voltage 50V Max Current 1.0A Max
DC voltage 30V Max Current 5.0A Max Resistive Load; Inductive Load 3.0A Max
DC voltage 12V Max Current 5.0A Max

Code:

Ex db eb IIC T6 Gb
Ex tb IIIC T75 °C Db
IP66
-40°C ≤ Ta ≤ +70°C

Certificate No.:
SIRA 09ATEX3286X
IECEx SIR 09.0121X

Epsilon x:  II 2GD

CE Marking  2813
Notified body No.

Year/Serial No. i.e. 20/1CP6APB000001

**WARNING - DO NOT OPEN WHEN AN
EXPLOSIVE ATMOSPHERE MAY BE PRESENT
ELECTROSTATIC HAZARD – CLEAN ONLY
WITH A DAMP CLOTH**

3) Type Approval Standards

The call point has an EC Type examination certificate issued by SIRA and have been approved to the following standards: -

EN60079-0:2018 / IEC60079-0:2017
EN60079-1:2014 / IEC60079-1:2014
EN60079-7:2015 / IEC60079-7:2017
EN60079-18:2015 / IEC60079-18:2014
EN60079-31:2014 / IEC60079-31:2013

The equipment is certified for use in ambient temperatures in the range -40°C to +70°C and shall not be used outside this range.

4) Installation Requirements

Installation of this equipment shall only be carried out by suitably trained personnel in accordance with the applicable code of practice e.g. IEC 60079-14/EN 60079-14

Repair of this equipment shall only be carried out by the manufacturer or in accordance with the applicable code of practice e.g. IEC 60079-19/EN 60079-19.

Refer to certificates SIRA 09ATEX3286X and IECEx SIR 09.0121X for special conditions of safe use.

The certification of this equipment relies on the following materials used in its construction:

Enclosure: GRP - Glass Reinforced Polyester

Through enclosure mechanism: Plastic Nylon Zytel Injection Moulded

Sealing of enclosure and mechanism: O-ring Acrylonitrile-Butadiene Rubber

If the equipment is likely to come into contact with aggressive substances, then it is the responsibility of the user to take suitable precautions that prevent it from being adversely affected, thus ensuring that the type of protection is not compromised.

"Aggressive substances" - e.g. acidic liquids, gases or solvents that may affect polymeric materials.

"Suitable precautions" - e.g. regular checks as part of routine inspections or establishing from the material's data sheet that it is resistant to specific chemicals.

Under extreme conditions the unit may generate an ignition-capable level of electrostatic charges. The unit must not be installed in a location where it may be subjected to external conditions (such as high pressure steam) which may cause a build-up of electrostatic charges on non-conducting surfaces.

Cleaning of the unit must only be carried out with a damp cloth.

5) Call Point Location and Mounting

The location of the call point should enable ease of access for operation and testing. The unit should be mounted using the 4 off fixing holes which will accept up to M5 sized fixings.

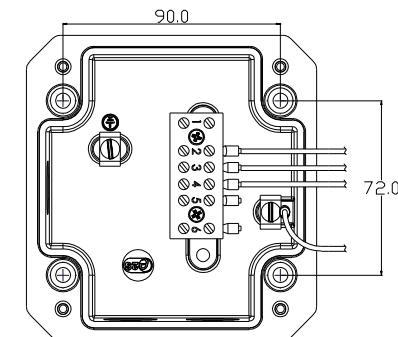

View of base unit showing fixing centres (in mm).

To gain access to the mounting holes in the base the front cover must be removed. This is achieved by removing the 4 off M4 cap head bolts holding on the cover.

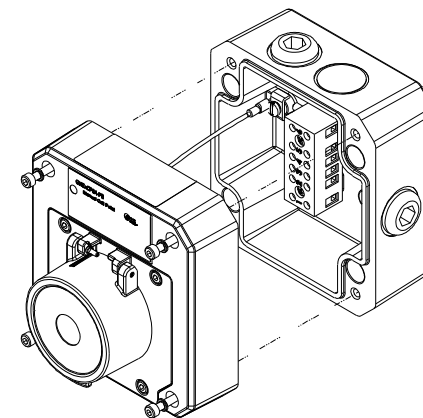

Once the screws are removed the cover will hang down out of the way to gain access to the Ex e terminal block, the internal earth terminal and mounting hole recesses.

6) Earthing

The unit has an internal earth terminal. It is recommended that a cable crimp lug is used on the earth wires.

The internal earth wire is placed under a earth clamp which will stop the cable twisting. This is secured by an M4 screw and spring washer.

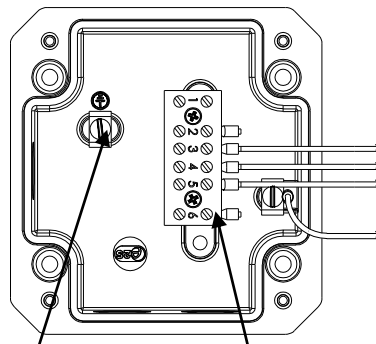

Internal Earth terminal Ex e terminal block

Note: Depending on options chosen an 8-Way DIN Rail or 6-Way terminal block may be selected.

7) Cable connections

There are 3 off cable entries for M20x1.5 Ex e approved cable glands or stopping plugs with a minimum ingress protection of IP66.

The unit can be wired in a number of different ways depending whether normally open or normally closed contacts are required. See wiring schematic D154-06-001 for wiring options.

When wiring to Increased Safety terminal enclosures, you are only permitted to connect one wire into each way on the terminal block, unless a pair of wires are crimped into a suitable ferrule. For the six-way terminal block wire sizes allowable are 0.5mm² to 4.0mm². For the 8-way DIN rail wire sizes allowable are 0.5mm² to 2.5mm²

Leads connected to the terminals shall be insulated for the appropriate voltage and this insulation shall extend to within 1mm of the metal of the terminal throat. They shall only be installed and wired with cable in an ambient temperature of -10°C to +80°C

All terminal screws, used or unused, shall be tightened down to between 0.5 Nm and 0.7 Nm.

8) Testing unit operation

The push button unit can be tested without the need to replace any element.

To test, lift the cover lift flap to reveal the push button. The button should be pressed into the body to activate the unit and place it into the operated condition.

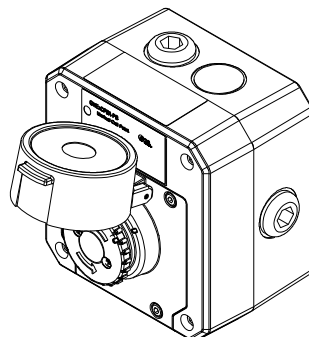

The call point switch will now change over its contacts to operate the alarm.

Once testing is complete the unit needs to be reset from the operated condition.

Rotate the push button anticlockwise by an angle of 55°, see guide alignment marks on the button and cover, shown below (1). The push button should pop back up to its original position. Ensure that the push button has also twisted back clockwise by 55° to its original position see guide marks on button and cover, shown below (2). The unit is now reset.

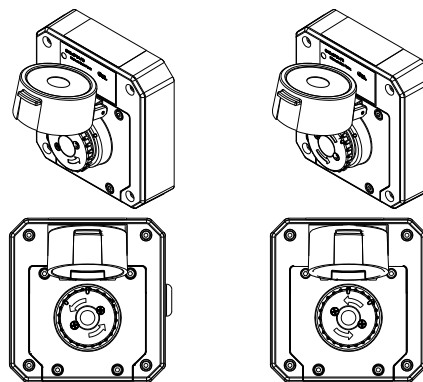

1. On operated unit twist push button anticlockwise 55° to reset

2. Button should pop up and twist back to original position

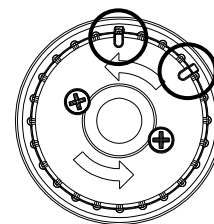

Note: use alignment marks circled to indicate the push buttons status/position

Unit currently shown as 'standby condition'

Resetting an operated unit is the same as resetting a tested unit.

9) SIL 2 Reliability Data

Reliability and Functional safety IEC/EN61508 which has been assessed and is considered suitable for use in low demand safety function:

- Random Hardware Failures and Systematic Failures (route 2H)
- As an unvoted item (i.e. hardware fault tolerance of 0) at SIL 2

The product was assessed against failure modes:

- Failure to close a contact when the call point is struck with specified force
- Failure to open a contact when the call point is struck with specified force
- Spurious output despite no input

Integrity in respect of failure to close	SIL 2
Total Failure rate	0.133 pmh
"hazardous" failure rate (revealed)	0 pmh
"hazardous" failure rate (unrevealed)	0.1 pmh
"safe" failure rate (revealed)	0.033 pmh
"safe" failure rate (unrevealed)	0
Diagnostic Coverage	99%
System type	A
Hardware Fault Tolerance	0
Safe Failure Fraction	>99%
PFD (hazardous failure)	1.25 x 10 ⁻³
Proof Test Interval	Up to 1 year



SCATTERGOOD & JOHNSON LTD

ELECTRICAL ENGINEERING & FLUID CONTROL DISTRIBUTORS

Est.1899

At Scattergood & Johnson Ltd, we pride ourselves on being a technical distributor to specialist industries.

Working with a range of quality product suppliers across a number of specialist markets, we are not your average 'box shifter' - we are your technical and supply chain partner.

We fully support every product we sell - for free! Our internal team and external sales engineers can answer any product or application question, no matter the complexity.

Backing up this technical ability is a range of 50,000+ products available from stock for nationwide next day delivery (same day if required!), or you can collect what you need from any of our trade counters around the UK.

Select your specialist interest below to learn more about how we can help.



Online, In Branch and On the Road - Scattergood & Johnson Ltd, there when you need us.

www.scatts.co.uk