

Technical Information

Nivotester FTW325

Conductive



Point level switch with intrinsically safe signal circuit for connecting to conductive sensors

Application

- Two-point control also for hazardous areas
- Overflow protection for tanks
- Dry running protection for pumps
- Point level detection

Your benefits

- Cable monitoring up to sensor
- Adjustable sensitivity range
- ATEX, FM and CSA approval
- Measuring range up to 200 k Ω
- Alarm relay can also be used as a second point level relay (SPDT)
- Compact housing for easy series mounting on standard DIN rail in the cabinet
- Pluggable terminal blocks make wiring easy
- Connection to different supply voltages

Table of contents

Function and system design	3	Documentation	11
Measuring principle	3	Technical Information	11
Measuring system	5	Operating Instructions	11
Input	6	Certificates	12
Measured variable	6		
Measuring range	6		
Input signal	6		
Output	6		
Output signal	6		
Overvoltage category as per EN 61010	7		
Protection class	7		
Signal on alarm	7		
Galvanic isolation	7		
Power supply	7		
Electrical connection	7		
Supply voltage	7		
Power consumption	7		
Installation	8		
Installation instructions	8		
Environment	8		
Ambient temperatures	8		
Climatic and mechanical application class	8		
Degree of protection	8		
Electromagnetic compatibility (EMC)	8		
Mechanical construction	9		
Design, dimensions	9		
Materials	9		
Terminals	9		
Weight	9		
Operability	10		
Operating concept	10		
Display elements	10		
Operating elements	10		
Certificates and approvals	11		
CE mark	11		
Overfill protection	11		
Type of protection	11		
Ex approval	11		
Other standards and guidelines	11		
Ordering information	11		
Accessories	11		
Protective housing	11		

Function and system design

Measuring principle

Function

The Nivotester supplies a small amount of alternating current to the measuring point via the signal line. The cable is connected to the ground probe or the metal vessel and the probe. The voltage drops if an electrically conductive medium touches the probe. An amplifier circuit in the Nivotester causes the relays to switch.

Signal transmission

The intrinsically safe signal input of the Nivotester FTW325 is galvanically isolated from the power supply and from the output. The Nivotester supplies the conductive probe with alternating current via a two- or three-wire cable and monitors the voltage of this cable. If the medium reaches the switch point of the probe, the voltage between the probe and the Nivotester is reduced. The switching of the output relays at the Nivotester depends on which fail-safe mode has been configured. The switching state of the relays is indicated on the front panel of the Nivotester by means of two yellow LEDs.

Fail-safe mode

The choice of fail-safe mode affects how the relay works in quiescent current fail-safe mode.

- **MAX = Maximum fail-safe mode:**
the relay de-energizes when the level rises above the switch point (probe covered), a fault occurs or the power fails. Used for overflow protection, for example.
- **MIN = Minimum fail-safe mode:**
the relay de-energizes when the level falls below the switch point (probe uncovered), a fault occurs or the power fails. For use with dry running protection or pump protection, for instance.

2 x point level detection

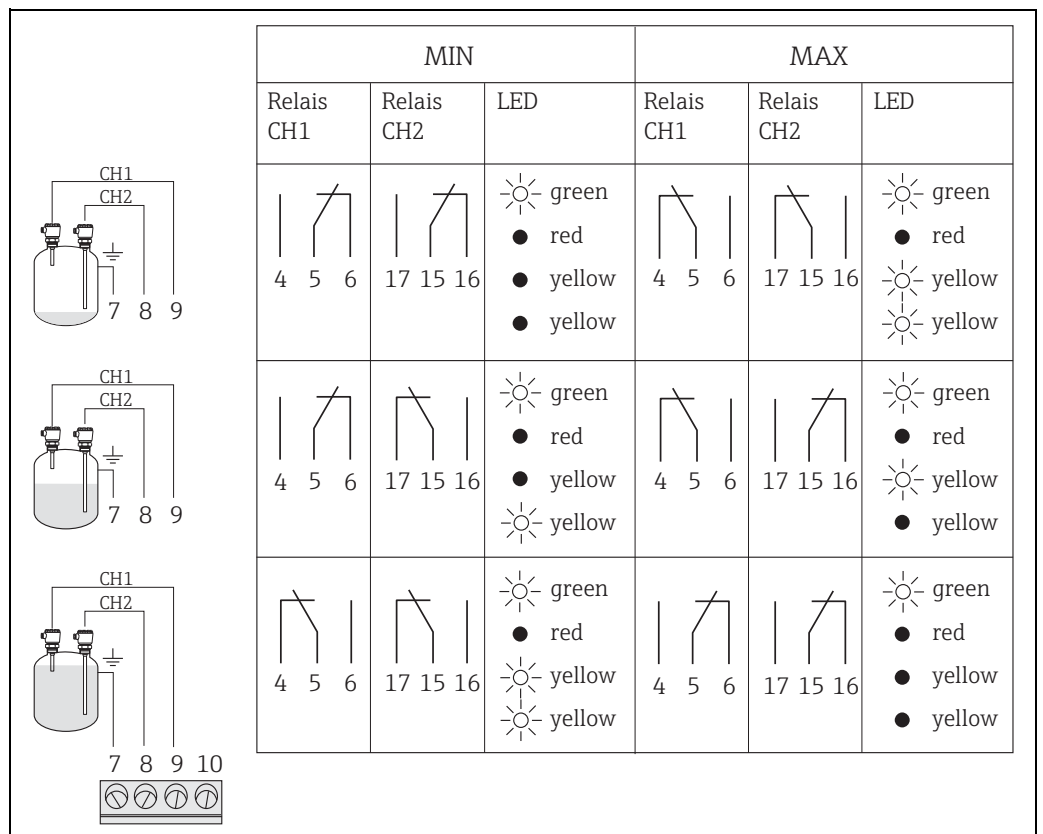

L00-FTW325xx-16-06-xx-xx-000

Function of point level indication depending on level and fail-safe mode.

Function monitoring

To increase operational safety, channel 1 (CH1) of the Nivotester is equipped with a function monitoring facility. A fault is indicated by a red LED and de-energizes both the level alarm relay and the alarm relay in CH1.

A fault is indicated if the voltage measured is too high. This occurs, for example, when:

- the signal line to the sensor is interrupted
- the sensor electronics are defective

Cable monitoring is implemented using probe types with an additional printed circuit board. This cable monitoring is switched on or off via a DIL switch on the Nivotester.

Probes with integrated cable monitoring: Liquipoint T, FTW31, FTW32 (separate instrumentation)

Adjustable switching delay

A slide switch is used to configure a switching delay of 0.5 s; 3 s; 5 s.

The switching delay takes effect only when the relay picks up - see also Fail-safe mode → 3.

Fail-safe mode can be configured separately

Two DIL switches allow the MIN/MAX setting for CH1 and CH2 to be configured separately.

Sensitivity range

DIL switches are used to configure three resistance ranges.

- up to 1.0 k Ω
- up to 10.0 k Ω
- up to 200.0 k Ω (standard setting for most liquids)

Fine-tuning is performed using a trimmer.

Master-slave function when using two Nivotester devices applied to one tank

Using a DIL switch, the Nivotester FTW325 can be configured as a master or as a slave. This is important in preventing a phase shift between the supply signals. The supply signal of the "slave" is synchronized with the supply signal of the "master".

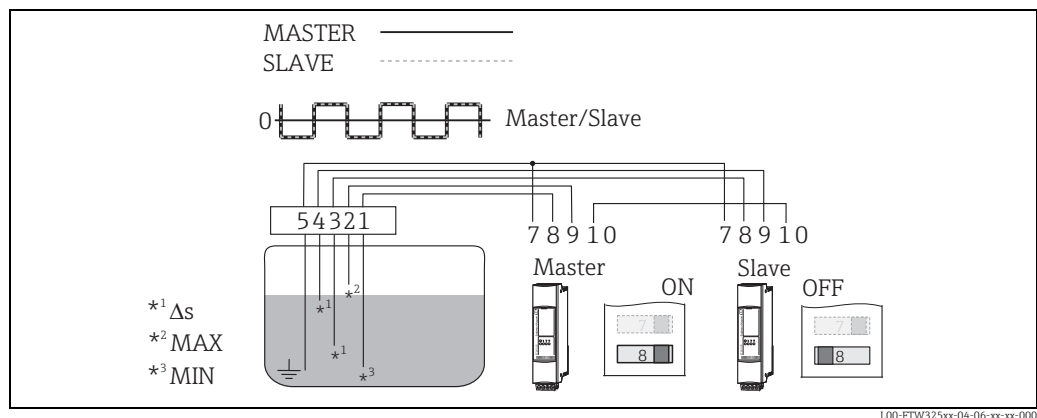

See: Operating elements → 10

Configuration of second output relay

The second alarm relay / level relay can be configured as follows:

- as a second level relay for probe 1 (relay switches in the same way as relay for CH1)
- as a level relay for CH2
- as an alarm relay

Measuring system

A simple measuring system consists of a probe, a Nivotester and a control or signal instrument.

Single-point control with Nivotester FTW325

The measuring system consists of:

- Probe (CH1)
- Nivotester FTW325
- Control or signal instruments

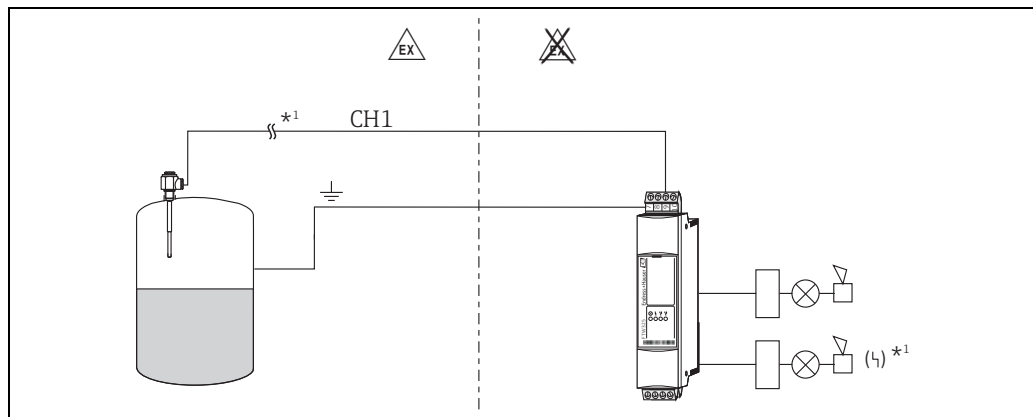

*1 Cable monitoring depends on probe type

Two single-point controls (point level detection) with Nivotester FTW325

The measuring system consists of:

- Probe 1 (CH1)
- Probe 2 (CH2)
- Nivotester FTW325
- Control or signal instruments

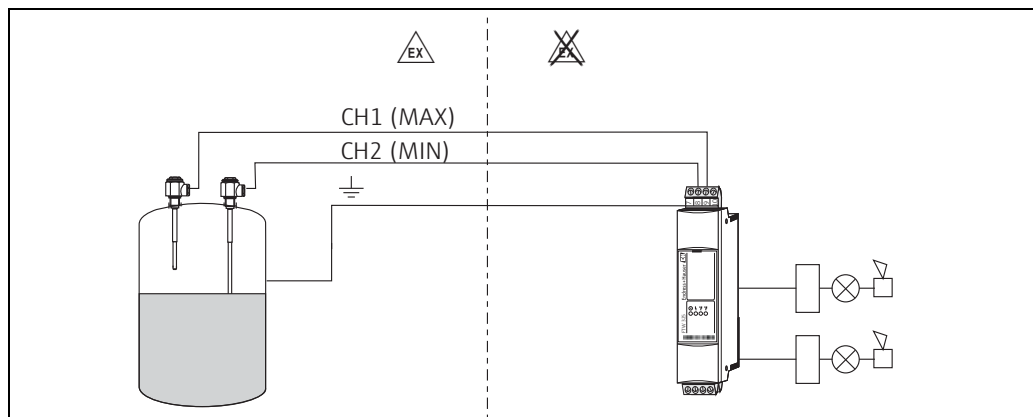

Two-point control Δs (pump control) with Nivotester FTW325

The measuring system consists of:

- Probe 1 (CH1)
- Probe 2 (CH2)
- Nivotester FTW325
- Control or signal instruments
- The two-point control (Δs) can be activated or deactivated via a DIL switch

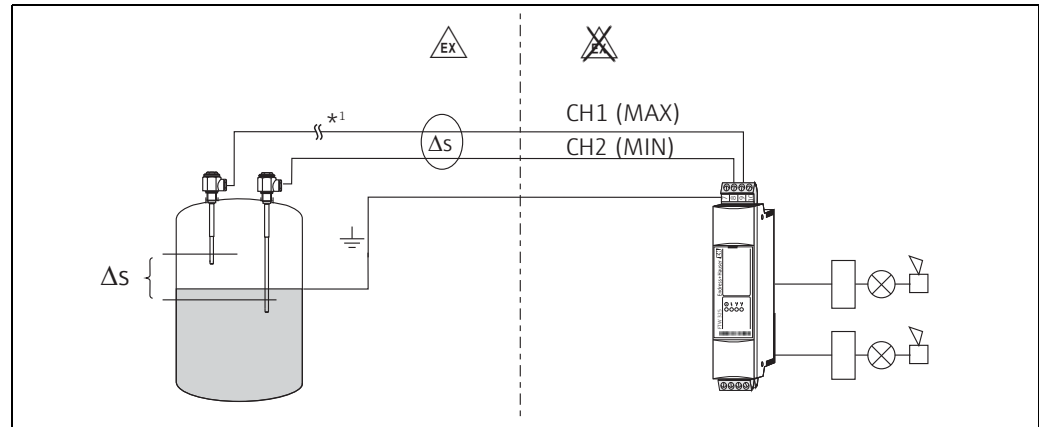

*1 Cable monitoring depends on probe type

L00-FTW325xxx-04-06-xx-xx-003

Input

Measured variable	The limit signal is generated at a MIN or MAX level, depending on the selection
Measuring range	The measuring range is dependent on the mounting location of the probes.

Input signal	<ul style="list-style-type: none"> ■ Input FTW325: galvanically isolated from supply and output ■ Type of protection: intrinsic safety [Ex ia Ga] IIC/IIB; [Ex ia Da] IIIC ■ Connectable sensors: Liquipoint T, FTW31, FTW32 ■ Power supply to sensors: with an AC signal Nivotester FTW325 ■ Connecting cable: two-/three-core, screening not required ■ Cable resistance: max. 25 Ω /per core
---------------------	---

Output

Output signal	<ul style="list-style-type: none"> ■ Relay output: two floating changeover contacts for level alarms ■ Quiescent current fail-safe circuit: MIN/MAX fail-safe mode can be selected using the DIL switch ■ Alarm relay: floating changeover contact for fault indication, can also be used as a second level relay ■ Switching delay: 0.5 s; 3.0 s; 5.0 s when relay picks up ■ Switching capacity of relay contacts: <ul style="list-style-type: none"> U~ maximum 250 V AC I ~ maximum 2 A P~ maximum 500 VA at $\cos \varphi \geq 0.7$ U- maximal 40 V DC I- maximum 2 A P- maximum 80 W ■ Operating life: at least 10^5 switching cycles at maximum contact load ■ Function indicators: LEDs for operation (gn), fault (rd), level alarm 1 (ye) and level alarm 2 (ye) ((ye) light up when the level relay picks up)
----------------------	---

Overvoltage category as per EN 61010	II
Protection class	II (double or reinforced insulation)
Signal on alarm	Limit relay de-energized, fault indication via red LED, alarm relay de-energized
Galvanic isolation	All input and output channels and relay contacts are safely galvanically isolated from each other. Safe galvanic isolation is guaranteed up to a voltage of 150 V AC if the supply circuit or the contacts of the alarm relay are connected simultaneously to the functional extra-low voltage.

Power supply

Electrical connection	<p>Terminal blocks</p> <p>The removable terminal blocks are divided into intrinsically safe connections (at the top of the device) and non-intrinsically safe connections (at the bottom of the device). Furthermore, the terminal blocks are also color-coded. Blue is for the intrinsically safe area and gray for the non-intrinsically safe area. These distinctions allow for safe cable routing.</p> <p>Sensor connection</p> <p>(To the upper, blue (hazardous area) / gray (non-hazardous area) terminal blocks). For the two- or three-core connecting cable between the Nivotester FTW325 and the sensor, use the usual commercial instrument cable or multi-core cable for measuring purposes. Cable resistance maximum 25 Ω per core. If strong electromagnetic interference is expected, e.g. from machines or radios, a screened cable must be used. Connect the screening only to the grounding connection in the sensor and not to the Nivotester.</p> <p>Using the sensor in hazardous areas</p> <p>The national explosion protection regulations for the design and routing of the intrinsically safe signal cable must be observed. The maximum permitted values for capacitance and inductance can be found in the Safety Instructions XA00196F.</p> <p>Connection of signal and control instruments</p> <p>(To the lower, gray terminal blocks) The relay function must be observed dependent on the level and fail-safe mode. If a device with high inductance (e.g. contactor, solenoid valve, etc.) is connected, a spark suppressor must be provided to protect the relay contact.</p> <p>Supply voltage connection</p> <p>(To the lower, green terminal blocks) As a fuse (AC: T 250 mA / DC: 400 mA) is incorporated in the power circuit, it is not necessary to connect an upstream fine-wire fuse. The Nivotester is equipped with reverse polarity protection.</p>
Supply voltage	<p>Alternating current version (AC):</p> <p>Voltage ranges: 85 to 253 V AC, 50/60 Hz</p> <p>Direct current version (DC):</p> <ul style="list-style-type: none"> ■ Voltage range: 20...30 V AC / 20...60 V DC ■ Power supply direct current: maximum 60 mA ■ Permitted residual ripple within the tolerance: $U_{ss} = \text{maximum } 2 \text{ V}$
Power consumption	<p>AC: maximum 5.2 VA</p> <p>DC: maximum 1.2 W (at 20 V)</p>

Installation

Installation instructions

Installation location

The Nivotester must be housed outside of hazardous areas in a cabinet. A protective housing (→ 11 "Accessories") is also available for installation outdoors.

NOTICE

The devices should be mounted in areas which are protected from weather conditions and impact and, if possible, which are not exposed to direct sunlight. This is of particular importance in warmer climates.

Orientation

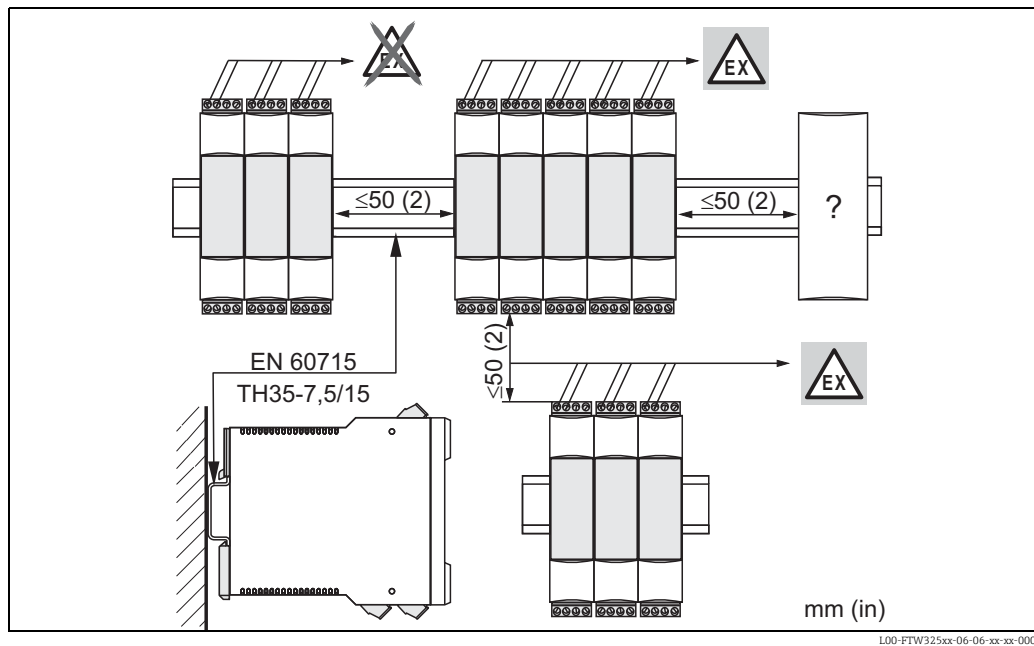

L00-FTW325xxx-06-06-xx-xx-000

Environment

Ambient temperatures

- For single mounting: -20 to $+60$ °C (-4 to $+140$ °F)
- For series mounting without lateral spacing: -20 to $+50$ °C (-4 to $+122$ °F)
- Storage temperature: -25 to $+85$ °C (-77 to $+185$ °F)
- Installation of a maximum of four Nivotester devices in the protective housing: -20 to $+40$ °C (-4 to $+104$ °F)

Climatic and mechanical application class

3K3: as per DIN EN 60721-3-3
3M2: as per DIN EN 60721-3-3

Degree of protection

- IP20 (as per EN 60529)
- IK06 (as per IEC 62262)

Electromagnetic compatibility (EMC)

Interference emission as per EN 61326; Equipment Class B
Interference immunity as per EN 61326; Annex A (Industrial) and NAMUR Recommendation NE 21 (EMC)

Mechanical construction

Design, dimensions

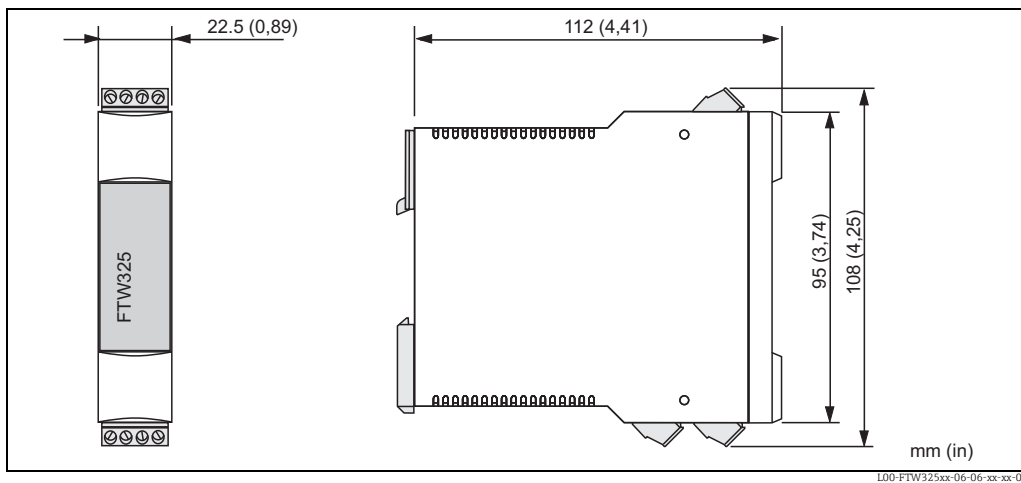

Materials

- Housing: polycarbonate, light gray (RAL 7035)
- Front cover: polypropylene PPN, blue
- Fixing bracket for securing on the DIN rail: polyamide PA6, black (RAL 9005)

Terminals

Nivotester FTW325

- 4 screw terminals: probe supply
- 3 screw terminals: limit relay
- 3 screw terminals: alarm relay/level relay
- 2 screw terminals: power supply

Connection cross-section

1 x ≤ 2.5 mm (1 x ≤ 14 AWG) or 2 x ≤ 1.5 mm (2 x ≤ 16 AWG)

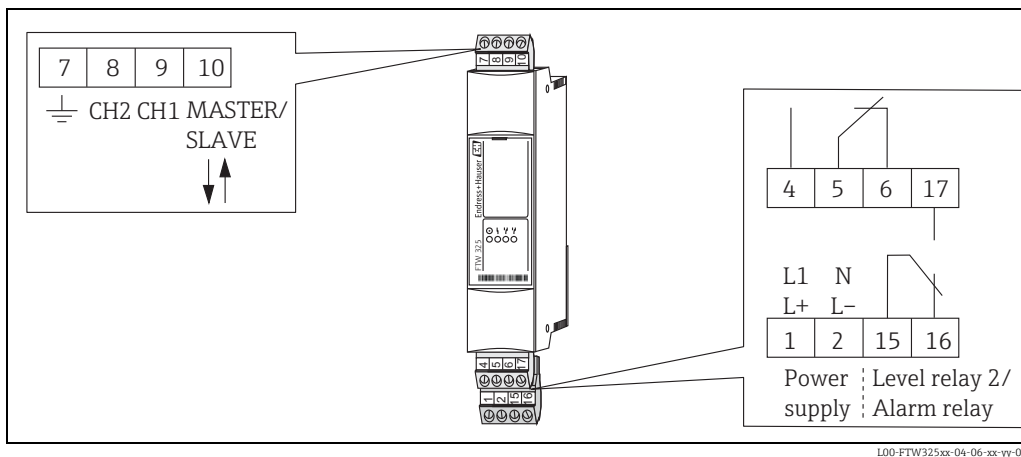

Weight

approx. 145 g (5.11 oz)

Operability

Operating concept On-site configuration with switches behind the folding front panel

Display elements

- green light emitting diode: standby
- red light emitting diode: fault indication
- yellow LED: level relay 1 picked up
- yellow LED: level relay 2 picked up

Operating elements

Nivotester FTW325

- A Configure time delay 0.5 s; 3.0 s; 5.0 s
- B DIL switch 1-3: adjustable resistance ranges
- Range 1: up to 1.0 k Ω
 - Range 2: up to 10.0 k Ω
 - Range 3: up to 200.0 k Ω
- DIL switch 4: Δ s (pump control)
- DIL switch 5: Channel 1 (CH1) MIN/MAX
- DIL switch 6: Channel 2 (CH2) MIN/MAX
- DIL switch 7: Cable monitoring on/off
- DIL switch 8: Master/slave configuration
- C Output 2 Configuration
- Second level relay for CH1 (MAX probe)
 - Level relay for CH2 (MIN probe)
 - Alarm relay
- D Adjustment trimmer

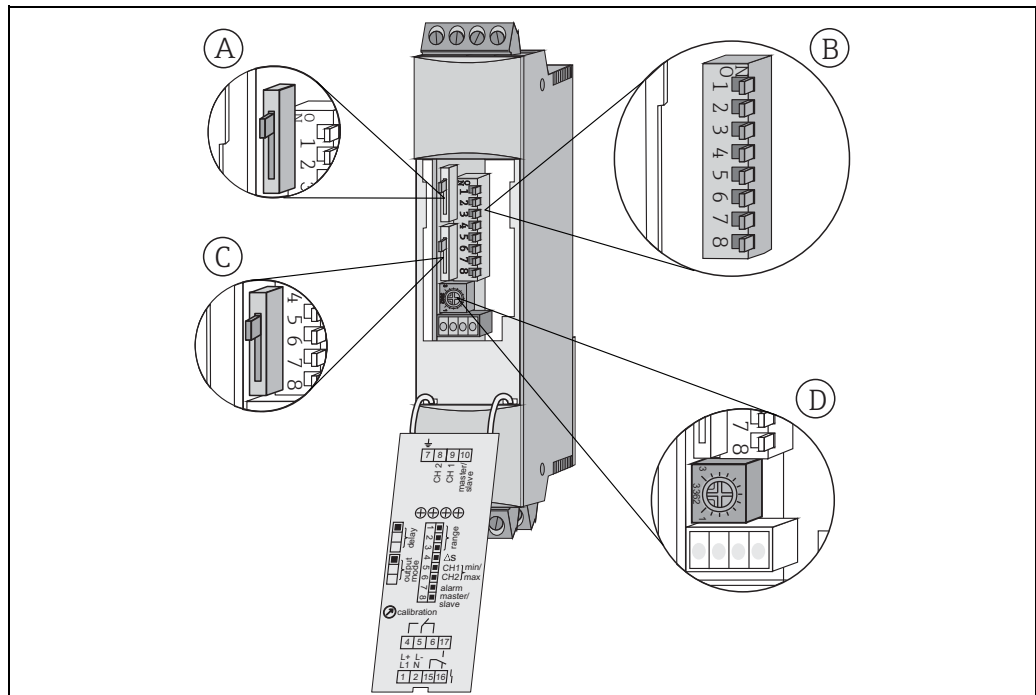

Certificates and approvals

CE mark	The Nivotester meets all the statutory requirements arising from EC directives. Endress+Hauser confirms the successful testing of the device by affixing the CE symbol.
Overfill protection	WHG
Type of protection	II (1) G [Ex ia Ga] IIC/IIB II (1) D [Ex ia Da] IIIC
Ex approval	Endress+Hauser Sales Centers provide information about the versions currently available for use in hazardous areas. All data relevant to explosion protection are contained in separate documents → 11 "Documentation", which can be requested if needed.
Other standards and guidelines	Other standards and guidelines which were observed during the design and development of the Nivotester FTW325. <ul style="list-style-type: none"> ▪ EN 60529: Degrees of protection provided by enclosures (IP code) ▪ EN 61010: Safety requirements for electrical equipment for measurement, control and laboratory use ▪ EN 61326: Interference emission (Equipment Class B), interference immunity (Annex A - Industrial)

Ordering information

NOTICE

Further details on product configuration and product features can be found on our product pages at www.endress.com.

Accessories

Protective housing	The protective housing (protection class IP 66) is equipped with an integrated DIN rail and closed by means of a transparent cover, which can also be lead-sealed. <ul style="list-style-type: none"> ▪ Dimensions: W 180 / H 182 / D 165 ▪ Color: Light gray RAL 7035; part number: 52010132
---------------------------	---

Documentation

Technical Information	<p>Conductive point level probes</p> <p>Liquipoint T FTW31, FTW32 TI00375F</p> <p>Protective housing</p> <p>TI00367F</p>
Operating Instructions	<ul style="list-style-type: none"> ▪ Nivotester FTW325 KA00199F ▪ Liquipoint T (separate instrumentation) KA00203F ▪ Liquipoint T (compact instrumentation) KA00204F

Certificates

ATEX:

- Nivotester: XA00196F

DIBt:

- Nivotester: ZE00043F
- Liquipoint T: ZE00257F



71269925

www.addresses.endress.com



SCATTERGOOD & JOHNSON LTD

ELECTRICAL ENGINEERING & FLUID CONTROL DISTRIBUTORS

Est.1899

At Scattergood & Johnson Ltd, we pride ourselves on being a technical distributor to specialist industries.

Working with a range of quality product suppliers across a number of specialist markets, we are not your average 'box shifter' - we are your technical and supply chain partner.

We fully support every product we sell - for free! Our internal team and external sales engineers can answer any product or application question, no matter the complexity.

Backing up this technical ability is a range of 50,000+ products available from stock for nationwide next day delivery (same day if required!), or you can collect what you need from any of our trade counters around the UK.

Select your specialist interest below to learn more about how we can help.



Online, In Branch and On the Road - Scattergood & Johnson Ltd, there when you need us.

www.scatts.co.uk