

Technical Information

Minicap

FTC260, FTC262

Capacitive

Point level switch with buildup compensation
No calibration necessary



Application

The Minicap is designed for point level detection in light bulk solids with a grain size up to max. 30 mm (1.18 in) and a dielectric constant $\epsilon_r \geq 1.6$ e.g. grain products, flour, milk powder, animal feed, cement, chalk or gypsum.

Versions:

- Minicap FTC260: with rod probe for bulk solids and liquids
- Minicap FTC262: with rope probe up to 6 m (20 ft); for bulk solids
- Relay output (potential-free change-over contact / SPDT) with AC or DC power
- PNP output with three-wire DC power

Your Benefits

- Complete unit consisting of the probe and electronic insert:
 - simple mounting
 - no calibration on start-up
- Active build-up compensation
 - accurate switch point
 - high operational safety
- Mechanically rugged
 - no wearing parts
 - long operating life
 - no maintenance
- The rope probe of the Minicap FTC262 can be shortened
 - optimum matching to the measuring point
 - less stocks required

Table of contents

Function and system design	3	Tensile strength	13
Measuring principle	3	Operability	13
Measuring System	3	Display elements	13
Function Range	4	Operating elements	13
Setting the Sensitivity	4	Certificates and approvals	14
Fail-safe mode	5	CE mark	14
Input	5	Ex approval	14
Measured variable	5	RCM-Tick marking	14
Measuring range	5	Ordering information	14
Output	6	Accessories	14
Output signal	6	Supplementary documentation	15
Signal on alarm	6	Operating manual (BA)	15
Switching delay when free or covered	6	Safety instructions (XA)	15
Overvoltage category	6		
Protection class	6		
Power supply	6		
Electrical connection	6		
Supply voltage	7		
Terminal compartment	7		
Performance characteristics	8		
Reference operating conditions	8		
Hysteresis	8		
Switch point	8		
Power up response	8		
Long-term drift	8		
Influence of medium temperature	8		
Installation	8		
Installation	8		
Installation instructions FTC260	9		
Installation instructions FTC262	10		
Environment	11		
Ambient temperature Ta	11		
Storage temperature	11		
Climate class	11		
Degree of protection	11		
Impact resistance	11		
Vibrational resistance	11		
Electromagnetic compatibility	11		
Operating height	11		
Process	11		
Process temperature Tp	11		
Process pressure range pp	11		
Temperature diagrams	11		
Mechanical construction	12		
Design and dimensions	12		
Material for wetted parts	13		
Process connections	13		
Housing, cable entry	13		

Function and system design

Measuring principle

Point Level Detection

A metal plate at the end of the probe, within the insulation, the integrated counter-electrode and the surroundings combine to form the two electrodes of a capacitor.

If the probe is covered or free of process medium, the capacitance changes and the Minicap switches.

Active Build-up Compensation

The Minicap detects build-up on the probe and compensates for its effects so that the switch point is always observed. The effects of build-up compensation depend on:

- the thickness of the buildup on the probe,
- the conductivity of the buildup,
- the sensitivity setting on the electronic insert.

Measuring System

Minicap is an electronic switch. The complete measuring system consists of:

- the Minicap FTC260 or FTC262
- a power supply and
- controllers, switching devices, signal transmitters (e.g. lamps, horns, PCS, PLC, etc.)

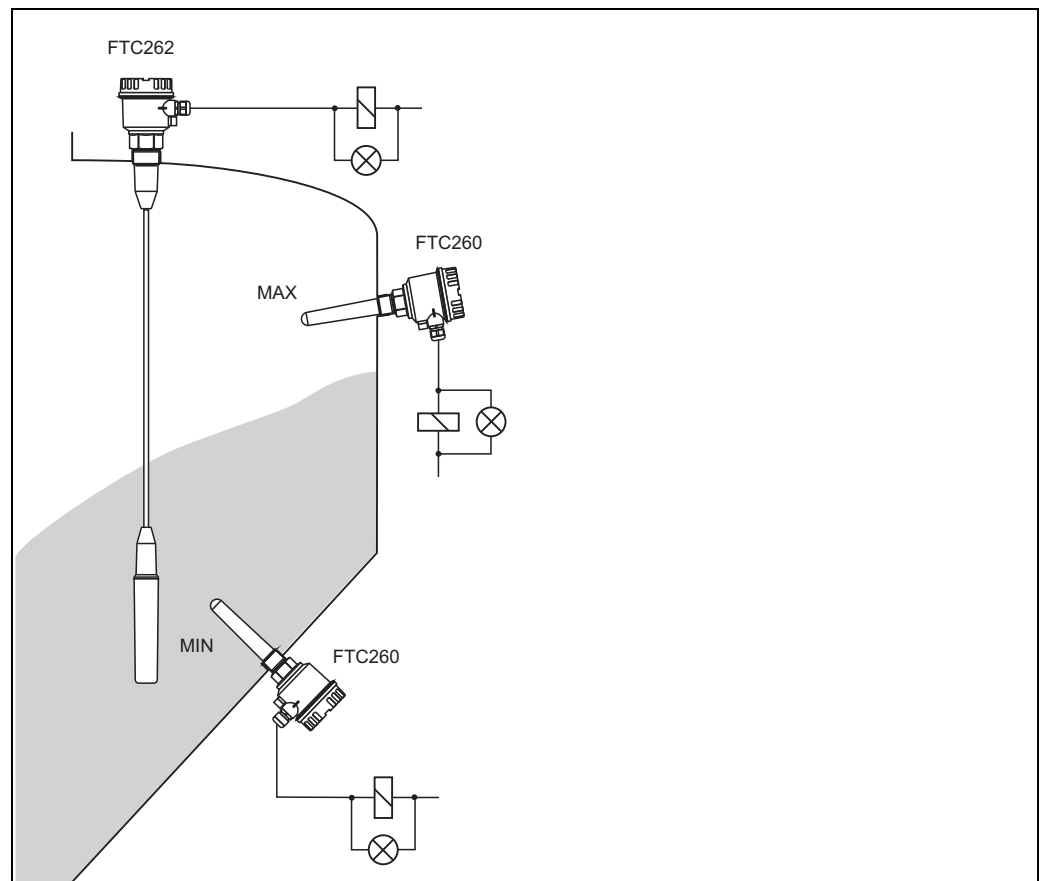

Point level detection in silos containing solids

L00-FTC26xxx-14-06-xx-xx-001

Function Range

There is a loose relationship between the dielectric constant ϵ_r and the density ρ of the material. The table on the left indicates whether the Minicap can be used or if application limits are exceeded.

Grain, seed, legumes and their products			Minerals, inorganic materials			Plastics		
Examples	ρ in g/l (approx.)	ϵ_r (approx.)	Examples	ρ in g/l (approx.)	ϵ_r (approx.)	Examples	ρ in g/l (approx.)	ϵ_r (approx.)
Rice	770	3.0	Cement	1050	2.2	ABS granulate	630	1.7
Cornstarch (packed)	680	2.6	Plaster	730	1.8	PA granulate	620	1.7
Flour (wheat)	580	2.4	Chalk (packed)*	540	1.6	PE granulate*	560	1.5
Corn grist	500	2.1	Chalk (loose)*	360	1.4	PVC powder*	550	1.4
Sunflower seeds	380	1.9				PU dust*	80	1.1
Noodles	370	1.9						
Bran (wheat)	250	1.7						
Popcorn*	30	1.1						

* Gray background: Application limits not reached => Use Soliphant FTM as point level switch.

In general:

If the dielectric constant of the process medium is not known, then the bulk density can be a deciding factor.

Experience shows that the Minicap functions in foodstuffs with a density of 250 g/l and above or in plastic or mineral materials with a density of 600 g/l and above.

Setting the Sensitivity

The Minicap is so calibrated at the factory that it correctly switches in most materials. Greater sensitivity can be set using a switch on the electronic insert. This is necessary if there is very strong build-up on the probe, or if the dielectric constant ϵ_r of the material is very small.

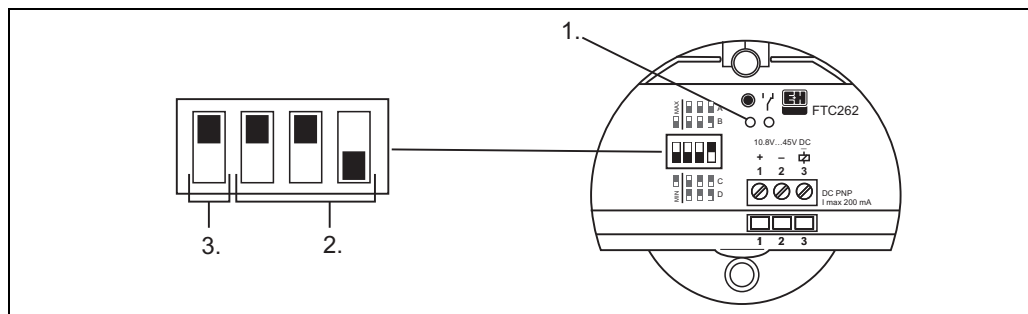

The switch positions show the factory settings:

- 1 LEDs
- 2 Switch for setting sensitivity
- 3 Switch for selecting safety position

Fail-safe mode

MIN-/MAX detection on the electronic insert, switchable.

MIN

The output switches if the probe is uncovered or if the supply voltage is disconnected in a safety-oriented manner (signal on alarm). Used for dry-running protection and pump protection, for example.

MAX

The output switches if the probe is covered or if the supply voltage is disconnected in a safety-oriented manner (signal on alarm). Used for overflow protection, for example.

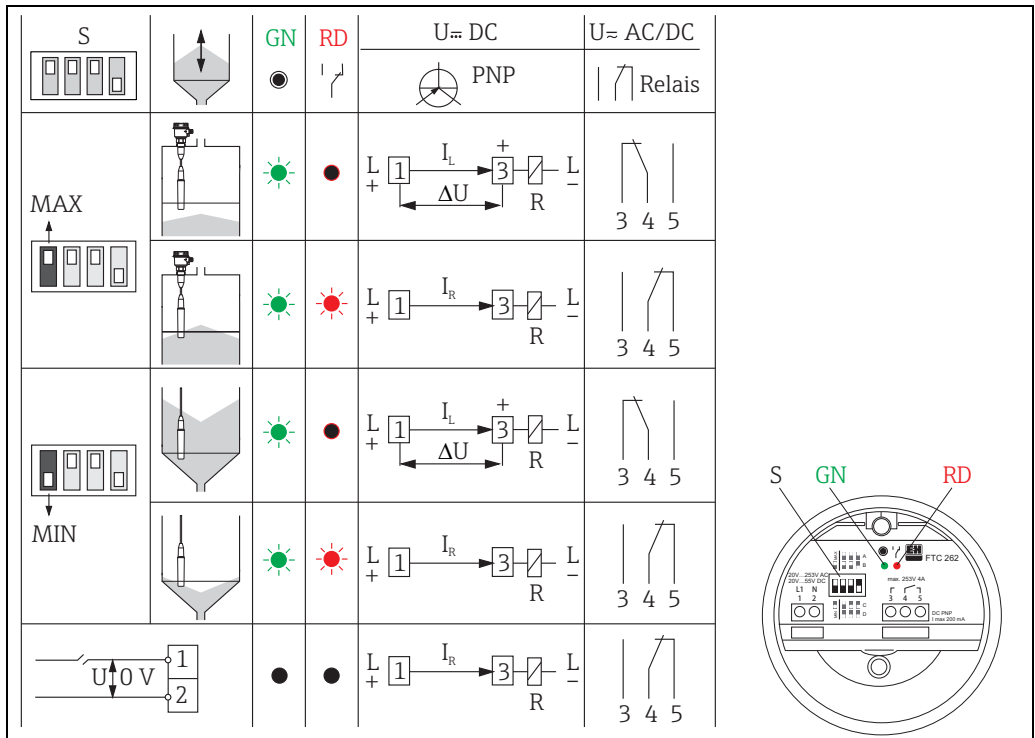

Function and selection of fail-safe mode

Input

Measured variable

Point level

Measuring range

- FTC260: $\epsilon_r \geq 1.6$
- FTC262: $\epsilon_r \geq 1.5$

Output

Output signal	<ul style="list-style-type: none"> ■ DC, PNP transistor output: Switching: PNP I_{\max} 200 mA <ul style="list-style-type: none"> – overload and short circuit protection – residual voltage at transistor at $I_{\max} < 2.9$ V ■ AC / DC, Relay output: Contact: change-over, potential-free U_{\max}^{\sim} 253 V, I_{\max}^{\sim} 4 A (AC) P_{\max}^{\sim} 1000 VA, $\cos \varphi = 1$ P_{\max}^{\sim} 500 VA, $\cos \varphi > 0.7$ $I_{\max}^{\%}$ 4 A for $U_{\%} 30$ V $I_{\max}^{\%}$ 0.2 A for $U_{\%} 253$ V
Signal on alarm	<ul style="list-style-type: none"> ■ DC, PNP transistor output: $< 100 \mu\text{A}$ ■ AC / DC, Relay output: relay de-energized
Switching delay when free or covered	<ul style="list-style-type: none"> ■ FTC260: 0.5 s ■ FTC262: 0.8 s
Overvoltage category	Category II (as per EN 61010-1)
Protection class	Class I (as per EN 61010-1)

Power supply

Electrical connection	<p>To ensure that the Minicap operates safely and without electrical interference, it must be connected to an earthed silo with metal or reinforced concrete walls.</p> <p>For silos made of non-conductive materials, the external earth wire of the Minicap must be connected to a conductive and earthed component which is earthed near to the silo. The protective earth can be connected to the internal earth terminal of the Minicap.</p> <p>Connections can be made with standard instrument cabling.</p> <p>See TI00241F/00/EN for information on EMC (testing procedures, installation).</p> <p>Connect the potential matching lead (PAL) when using in dust explosion hazardous areas.</p> <p>Note national regulations!</p>
------------------------------	--

Minicap AC or DC connection and relay output

F1: Fine-wire fuse to protect the relay contact, dependent on the connected load

Fine-wire fuse, 500 mA

F2: Earth connection to silo or metal

M: components on silo

E: Earth

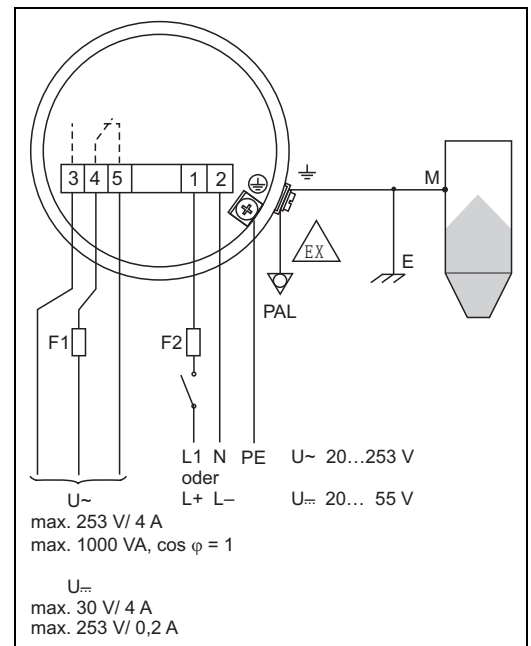

Minicap FTC260 with F14 housing: no ground lines (PE) or potential matching lines (PAL) are required.

Minicap with three-cable DC connection; Transistor output PNP

F: Fine-wire fuse, 500 mA

R: Connected load, e.g. PLC, PCS, relay

M: Earth connection to silo or metal components on silo

E: Earth

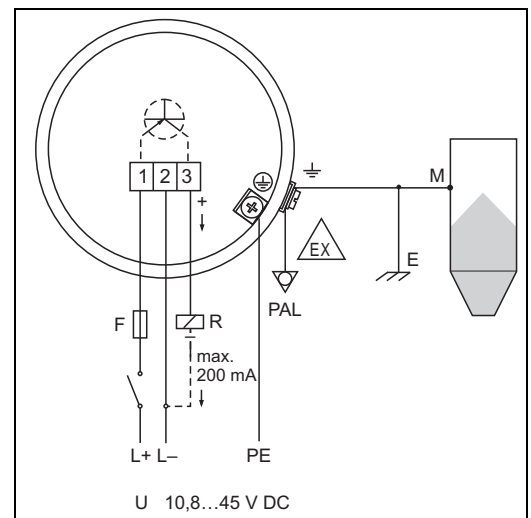

Minicap is protected against reverse polarity. The green LED for standby goes out if the connections are reversed.

Minicap FTC260 with F14 housing: no ground lines (PE) or potential matching lines (PAL) are required.

Supply voltage

- DC, PNP transistor output:
 - U% 10.8 to 45 V DC
 - transient pulses to 55 V
 - current consumption max. 30 mA
 - reverse polarity protected
- AC / DC, Relay output:
 - U~ 20 to 253 V AC or
 - U% 20 to 55 V DC
 - current consumption max. 130 mA

Terminal compartment

- Stranded wires max. 1.5 mm² (16 AWG) in end sleeves
- Electric wire max. 2.5 mm² (14 AWG)

Performance characteristics

Reference operating conditions	<p>In plastic container:</p> <ul style="list-style-type: none"> ■ Ambient temperature: 23 °C (73 °F) ■ Medium temperature: 23 °C (73 °F) ■ Medium pressure p_e: 0 bar (0 psi) ■ Medium: dielectric constant $\epsilon_r = 2.6$ ■ Conductivity: < 1 μS ■ Sensitivity setting: C 								
Hysteresis	<ul style="list-style-type: none"> ■ FTC260: 4 mm (0.16 in) horizontal, 7 mm (0.28 in) vertical ■ FTC262: 5 mm (0.2 in) vertical 								
Switch point	<ul style="list-style-type: none"> ■ FTC260: Probe center -5 mm (-0.2 in) horizontal, above probe tip 40 mm (1.57 in) vertical ■ FTC262: Above probe tip: 35 mm (1.38 in) vertical <p>Probe length tolerances; mm (in):</p> <table border="0"> <thead> <tr> <th>- Probe length L</th> <th>Tolerances</th> </tr> </thead> <tbody> <tr> <td>- up to 1000 (39.4)</td> <td>+0/-10 (+0/-0.39)</td> </tr> <tr> <td>- up to 3000 (118)</td> <td>+0/-20 (+0/-0.79)</td> </tr> <tr> <td>- up to 6000 (236)</td> <td>+0/-30 (+0/-1.18)</td> </tr> </tbody> </table>	- Probe length L	Tolerances	- up to 1000 (39.4)	+0/-10 (+0/-0.39)	- up to 3000 (118)	+0/-20 (+0/-0.79)	- up to 6000 (236)	+0/-30 (+0/-1.18)
- Probe length L	Tolerances								
- up to 1000 (39.4)	+0/-10 (+0/-0.39)								
- up to 3000 (118)	+0/-20 (+0/-0.79)								
- up to 6000 (236)	+0/-30 (+0/-1.18)								
Power up response	<ul style="list-style-type: none"> ■ FTC260: Correct switching after max. 1.5 s ■ FTC262: Correct switching after max. 2 s 								
Long-term drift	<ul style="list-style-type: none"> ■ FTC260: 3 mm (0.12 in) horizontal, 6 mm (0.24 in) vertical ■ FTC262: Vertical 6 mm (0.24 in) 								
Influence of medium temperature	Depending on material to be measured								

Installation

Installation

Silo Material

The Minicap can be used in a range of silos made of different materials.

Mounting Point

Note the angle of the material mounds and the outlet funnel when determining the mounting point or probe length of the FTC262.

NOTICE

The material flow must not be directed at the probe!

Installation instructions FTC260

Correct Installation

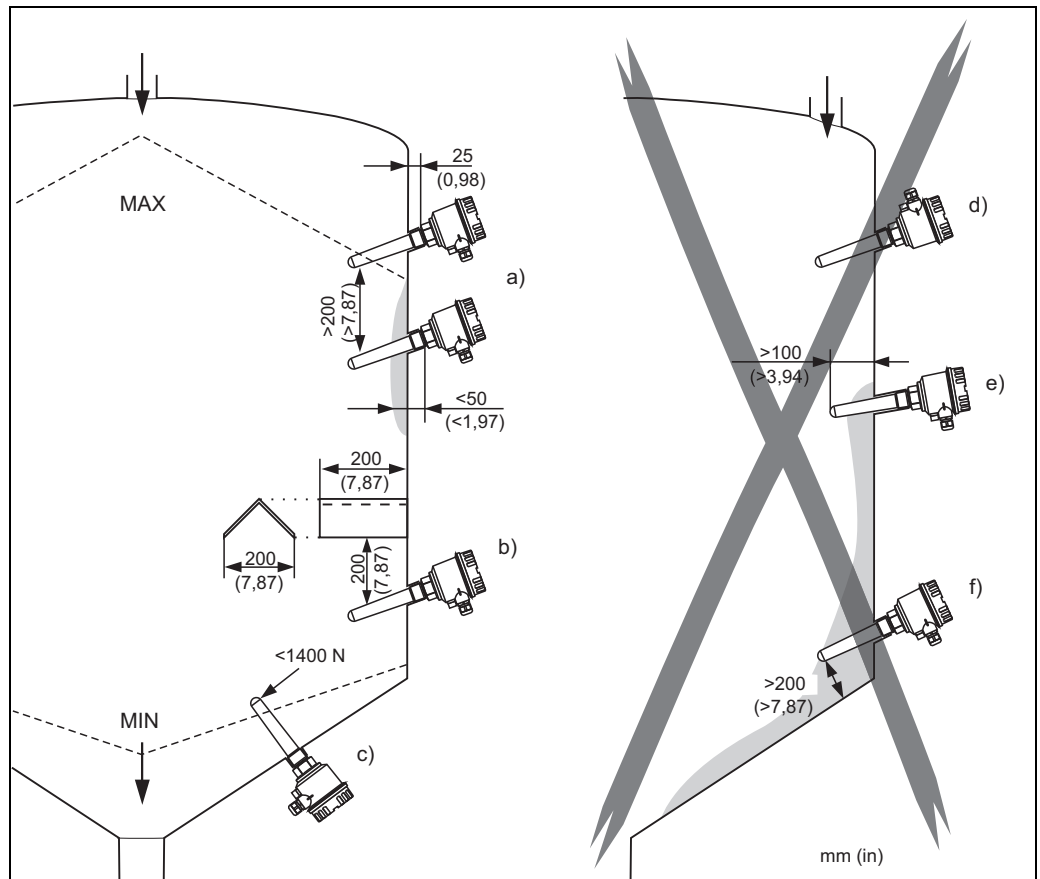

L00-FTC26xxx-11-06-xx-xx-001

General information and recommendations for installing a Minicap FTC260 point level switch

Correct Installation

- Minimum distances:**
To prevent mutual interference with the FTC260, there must be a minimum distance of 200 mm (7.87 in) between two probe tips.
- Mounting point:**
Tip of probe points slightly downwards so that process medium can slide off more easily.
The protective cover protects the probe rod from collapsing mounds or mechanical strain at the outflow when the Minicap FTC260 is set to minimum detection.
- Mechanical load:**
The maximum lateral load on the probe rod must be taken into account when used for minimum detection. It should therefore only be used for minimum detection with loose materials that have good flow characteristics.

Incorrect Installation

- The probe may be damaged by inflowing material, and cause faulty switching. Cable gland pointed upwards can allow moisture to enter.
- Threaded socket too long with material build-up on the silo wall. (Minimum mounting depth 100 mm (3.94 in) not reached).
- Mounted near build-up in the silo.
The probe tip is too near to a silo wall (less than a minimum distance of 200 mm (7.87 in)).

Environment

Ambient temperature T_a	-40 to +70 °C (-40 to +158 °F) For Dust-Ex version: -40 to +60 °C (-40 to +140 °F)
Storage temperature	-40 to +80 °C (-40 to +176 °F)
Climate class	As per EN 60068 part 2-38 (Z/AD), (IEC 68-2-38)
Degree of protection	IP66; Type 4 encl. (with F14 housing) IP66; Type 4x encl. (with F34 housing)
Impact resistance	Probe with F34 housing: 7 J
Vibrational resistance	EN 60068-2-64 (IEC 68-2-64), a(RMS) = 50 m/s ² ; ASD = 1.25 (m/s ²) ² /Hz; f = 5 to 2000 Hz, t = 3x2 h
Electromagnetic compatibility	Interference Emission to EN 61326, Electrical Equipment Class A Interference Immunity to EN 61326, Annex A (Industrial) and NAMUR Recommendation NE 21 (EMC) See TI00241F for general instructions regarding the EMC test conditions for E+H instruments.
Operating height	Up to 2000 m (6600 ft) above mean sea level.

Process

Process temperature T_p	<ul style="list-style-type: none"> ■ FTC260: -40 to +120 °C (-40 to +248 °F) Derating above $T_p = 80$ °C (176 °F): $T_p = 120$ °C @ $T_a = 50$ °C ($T_p = 248$ °F @ $T_a = 122$ °F) For Dust-Ex version: -40 to +80 °C (-40 to +176 °F) ■ FTC262: -40 to +80 °C (-40 to +176 °F)
Process pressure range p_p	<ul style="list-style-type: none"> ■ FTC260: -1 to +25 bar (-14.5 to +362 psi) ■ FTC262: -1 to +6 bar (-14.5 to +87 psi)

Temperature diagrams

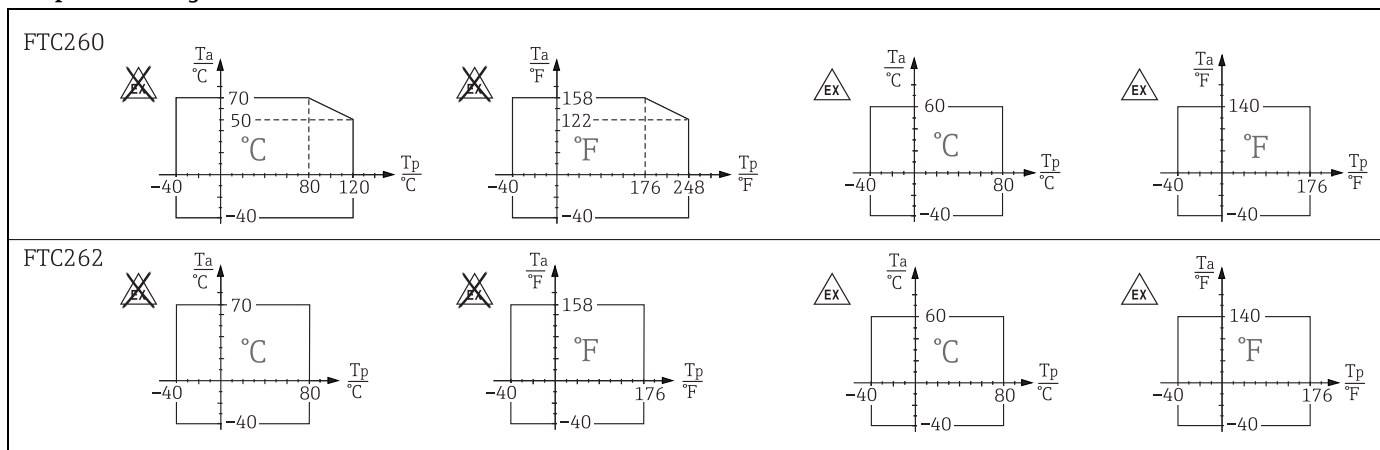

Mechanical construction

Design and dimensions

All dimensions in mm (in)!

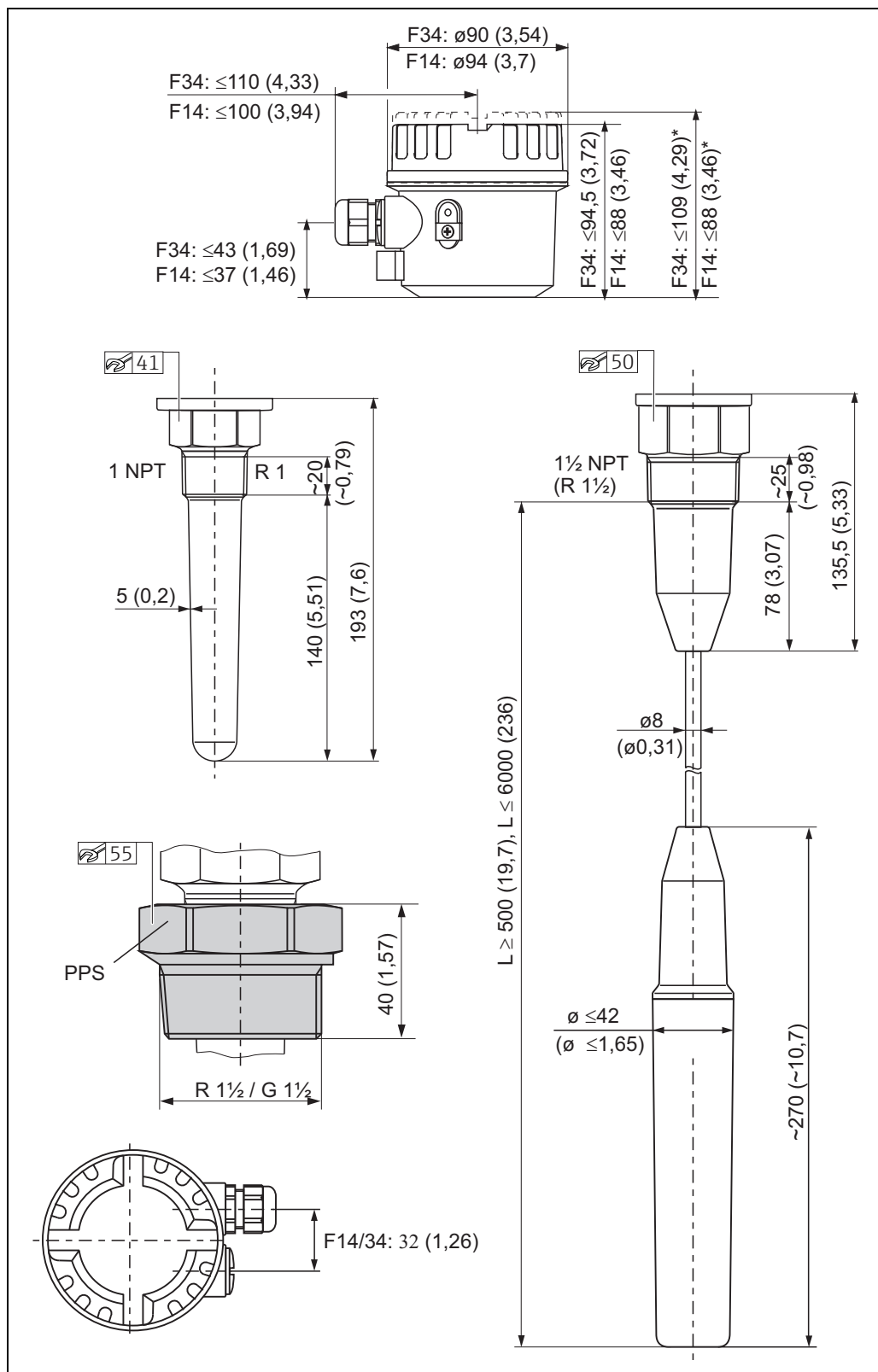

F14 = Polyester PBT-FR housing, IP66

F34 = Aluminum housing, IP66

* Cover with sight glass for F34 housing, cover with sight glass for F14 housing

Material for wetted parts	<ul style="list-style-type: none"> ■ Probe FTC260/FTC262: PPS GF40 FDA: FCN No. 000040: www.fda.gov/Food/IngredientsPackagingLabeling/EnvironmentalDecisions/ucm154090.htm Regulation (EC) No. 1935/2004 and No. 10/2011 ■ Probe rope FTC262: PE-HD ■ Probe rope seal FTC262: VMQ FDA: 21 CFR 177.2600
----------------------------------	---

Process connections	<p>Threaded boss:</p> <ul style="list-style-type: none"> ■ FTC260 <ul style="list-style-type: none"> - R 1, ISO 7/1 (DIN 2999), BSPT; adapter for R 1½ and G 1½, → 14 "Accessories" - 1 NPT, ANSI B 1.20.1; adapter for 1¼ NPT, → 14 "Accessories" ■ FTC262 <ul style="list-style-type: none"> - R 1½, ISO 7/1 (DIN2999), BSPT - 1½ NPT, ANSI B 1.20.1
----------------------------	--

Housing, cable entry	<ul style="list-style-type: none"> ■ Housing F14: polyester PBT-FR, IP66 <ul style="list-style-type: none"> - Coupling M20 - Thread NPT 1/2 - Thread G 1/2 ■ Housing F34: aluminum, IP66 <ul style="list-style-type: none"> - Coupling M20 - Thread NPT 1/2 - Thread G 1/2
-----------------------------	--

Tensile strength	FTC262
-------------------------	--------

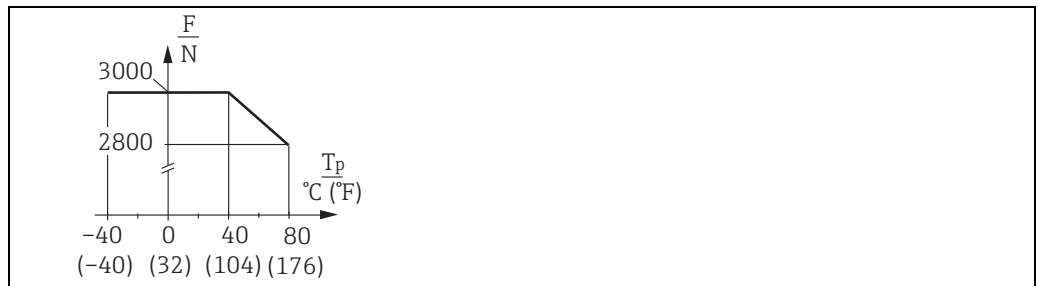

max. 3000 N up to 40 °C (104 °F)
max. 2800 N at 80 °C (176 °F)

L00-FTC26xxx-05-06-xxx-xx-003

Operability

Display elements	<ul style="list-style-type: none"> ■ Green LED: stand-by ■ Red LED: switch status
-------------------------	---

Operating elements	<p>Switch on electronic insert</p> <ul style="list-style-type: none"> ■ switching between minimum and maximum fail-safe mode ■ Sensitivity setting (depending on dielectric constant ϵ_r and buildup). It is usually not necessary to adjust the sensitivity (see "Measuring principle" section → 3)
---------------------------	--

Certificates and approvals

CE mark	The device complies with the legal requirements of the EU directives. In attaching the CE Mark, Endress+Hauser confirms that the device conforms to all relevant EU directives.
Ex approval	ATEX (in conjunction with F34 aluminum housing) FM and CSA (in preparation)
RCM-Tick marking	The supplied product or measuring system meets the ACMA (Australian Communications and Media Authority) requirements for network integrity, interoperability, performance characteristics as well as health and safety regulations. Here, especially the regulatory arrangements for electromagnetic compatibility are met. The products are labelled with the RCM- Tick marking on the name plate.



A0029561

Ordering information

Detailed ordering information is available from the following sources:

- In the Product Configurator on the Endress+Hauser website: www.endress.com → Click "Corporate" → Select your country → Click "Products" → Select the product using the filters and search field → Open product page → The "Configure" button to the right of the product image opens the Product Configurator.
- From your Endress+Hauser Sales Center: www.addresses.endress.com



Product Configurator - the tool for individual product configuration

- Up-to-the-minute configuration data
- Depending on the instrument: Direct input of measuring point-specific information such as measuring range or operating language
- Automatic verification of exclusion criteria
- Automatic creation of the order code and its breakdown in PDF or Excel output format
- Direct ability to order in the Endress+Hauser Online Shop

Accessories

A list of all accessories and spare parts is available at www.endress.com.

In the search field, simply enter the product name (e.g. Minicap) or the product code (e.g. FTC260), and select the desired product from the search results.

The "Accessories / Spare parts" section can be found in the lower section of the product page.

Supplementary documentation

Operating manual (BA)

- Minicap FTC260: KA00093F/00/A6
 - Minicap FTC262: KA00155F/00/A6
 - Rope shortening for FTC262: KA00157F/00/A6
-

Safety instructions (XA)

- Safety instructions (ATEX) for FTC260
XA00011F/00/A3
ATEX II 1/3D
- Safety instructions (ATEX) for FTC262
XA00092F/00/A3
ATEX II 1/3D



71438708

www.addresses.endress.com



SCATTERGOOD & JOHNSON LTD

ELECTRICAL ENGINEERING & FLUID CONTROL DISTRIBUTORS

Est.1899

At Scattergood & Johnson Ltd, we pride ourselves on being a technical distributor to specialist industries.

Working with a range of quality product suppliers across a number of specialist markets, we are not your average 'box shifter' - we are your technical and supply chain partner.

We fully support every product we sell - for free! Our internal team and external sales engineers can answer any product or application question, no matter the complexity.

Backing up this technical ability is a range of 50,000+ products available from stock for nationwide next day delivery (same day if required!), or you can collect what you need from any of our trade counters around the UK.

Select your specialist interest below to learn more about how we can help.



Online, In Branch and On the Road - Scattergood & Johnson Ltd, there when you need us.

www.scatts.co.uk