

# COMPACT SPOOL VALVES

**solenoid air operated**  
G1/4-G3/8 - ISO 5599/1  
subbase-mounted body

**5/2**  
Series  
**541**  
Type  
ISO size 1

## FEATURES

- Modular assembly with joinable subbases
- Subbases with side or bottom ports
- Version with manual spool position testers

## GENERAL

<b>Fluid</b>	Air or neutral gas, filtered, lubricated or not
<b>Operating pressure</b>	3 to 10 bar
<b>Ambient temperature</b>	-10°C to +60°C
<b>Flow (Qv at 6 bar)</b>	1050 l/min (ANR)
<b>Flow coefficient</b>	Kv = 15
<b>Life</b>	15 millions of cycles (in normal operating conditions)
<b>Base</b>	ISO 5599/01- Size 1
<b>Subbase</b>	Single subbase ISO/AFNOR NF E49085 Joinable subbase ISO/VDMA 24345 Joinable subbase with integrated functions

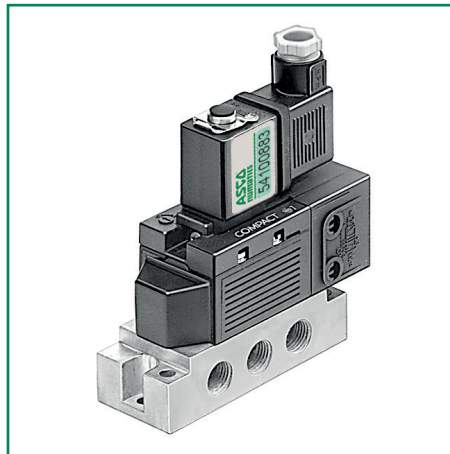

## CONSTRUCTION

### SPOOL VALVE

<b>Body and cover</b>	PA + FG (glass filled polyamide 6/6)
<b>Internal parts</b>	POM (polyacetal), light alloy and brass
<b>Seals</b>	NBR (nitrile) and PUR (polyurethane)

### BUILT-IN SOLENOID PILOT

<b>Seals</b>	NBR (nitrile) and PUR (polyurethane)
<b>Electrical devices</b>	Conforming to standard NF-C79300
<b>Coil and iron circuit</b>	Encapsulated monobloc, rotatable x 360°
<b>Exhaust</b>	M5 ports tapped, with exhaust plug
<b>Manual operator</b>	Maintained

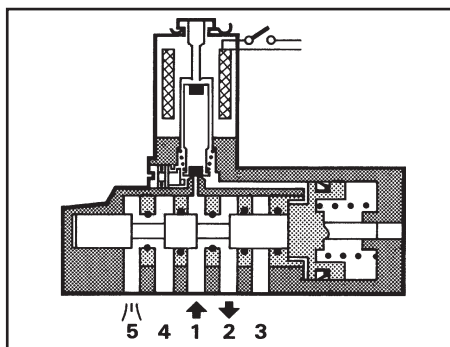

## ELECTRICAL CHARACTERISTICS

type of coil	voltage		consumption		insulation class	protection degree	electrical connection
	~	=	inrush	hold			
standard size 22	~	24V-48V-115V-230V-50Hz	6VA	3,5VA (2,5W)	F	IP 65	spade plug size 22 connector DIN 43650, 11 mm, industry standard B
	=	24V-48V	2,5W				

## SPECIFICATIONS

symbol	operators		response time (ms)		catalogue number		manual operator
	pilot (14)	return (12)	energized	de-energized	with connector	without connector	
	solenoid air operated	spring	18	70	54100883	54100884*	maintained

\* Option : connector with built-in visual indicator and electrical protection ( )

## SUBBASES

description	type	Ø	catalogue number
single subbase (ISO/AFNOR)	compact - side port	G 1/4	35500150
	bottom port	G 1/4	35500077
joinable subbase (ISO/VDMA)	bottom port	G 1/4	35500165
	1 set of 2 end plates (supply and exhaust side ports)	G 3/8	35500166

Other subbases:

00300GB-2017/R01  
Availability, design and specifications are subject to change without notice. All rights reserved.

**DIMENSIONS (mm), WEIGHT (kg)**

VALVE ON **SINGLE** SUBBASE

Code of subbase with **side** port : **35500150**

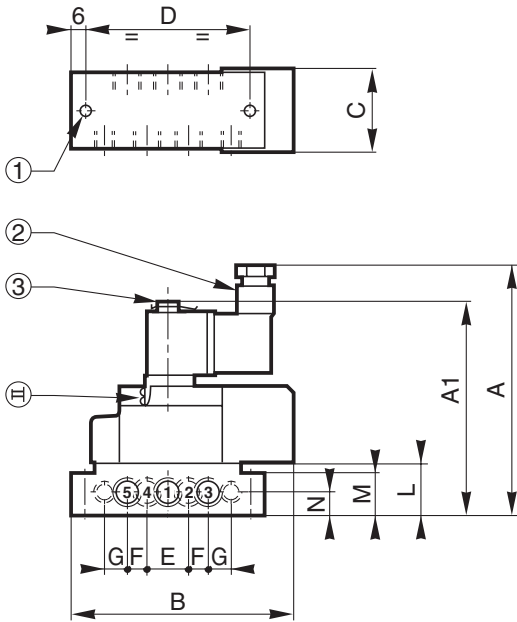

Code of subbase with **bottom** port : **35500077**

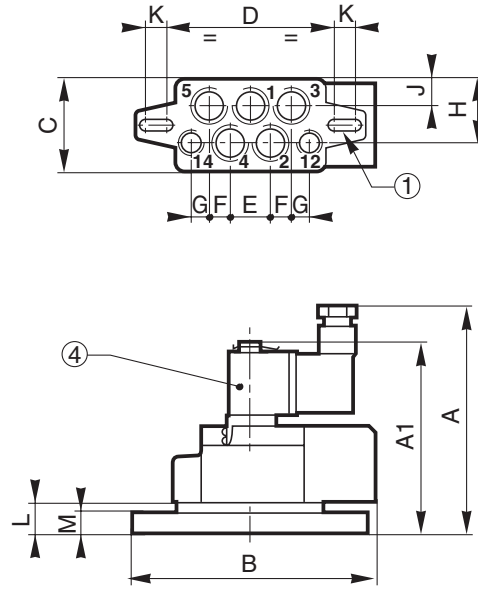

subbase catalogue number	port orifices			A	A1	B	C	D	E	F	G	H	J	K	L	M	N	weight
	12 - 14	2 - 4	1 - 3 - 5															
35500150	G 1/8	G 1/4	G 1/4	118	100	105	39	80	20	10	9	-	-	-	25	19	11	0,450
35500077	G 1/8	G 1/4	G 1/4	109	91	114	47	80	20	10	8,5	31	13,4	9	16	10	-	0,370

weight of compact monostable valve : 0.230 kg

VALVE ON **JOINABLE** SUBBASES WITH BOTTOM PORT ISO/VDMA

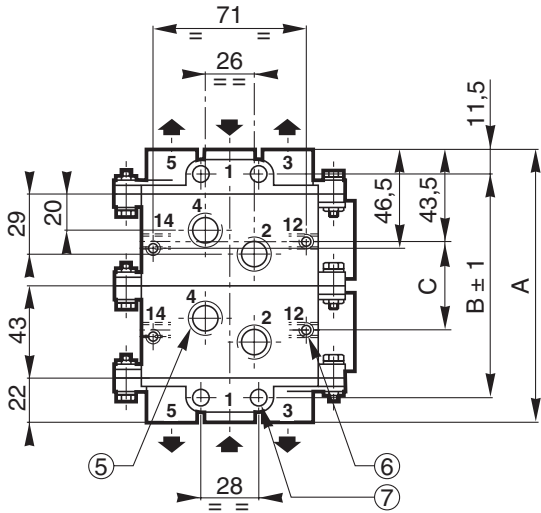

	catalogue number	port orifices		
		12-14	2-4	1-3-5
subbase	35500165	G 1/8	G 1/4	-
2 end plates	35500166	-	-	G 3/8

set of end plate supplied with 3 plugs G 3/8 (for 1-3-5)

number of subbases	A	B ± 1	C	weight
3	173	150	86	1,600
4	216	193	129	2,050
5	259	236	172	2,500
6	302	279	215	2,950
7	345	322	258	3,400
8	388	365	301	3,850

Weight = valves + subbases + end plates

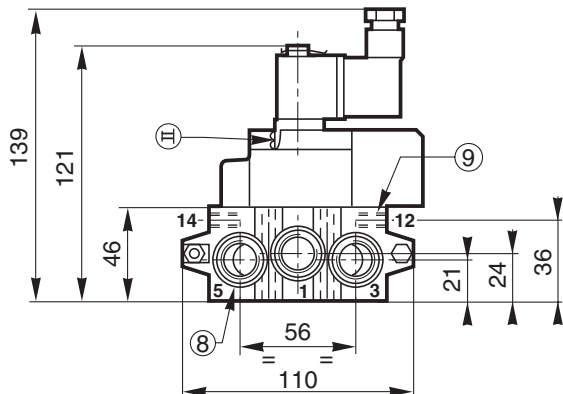

- ① Mounting : 2 Ø 5,5
- ② Size 22 connector
- ③ Port M5 depth 5.5
- ④ Coil rotatable x 360°
- ⑤ 2 ports G 1/4 (2-4)
- ⑥ Bottom mounting : 2 Ø M5
- ⑦ Mounting : 4 Ø 7
- ⑧ 3 ports G 3/8 (1-3-5)
- ⑨ 2 ports G 1/8 (12-14)
- Ⓜ Manual operator



# SCATTERGOOD & JOHNSON LTD

ELECTRICAL ENGINEERING & FLUID CONTROL DISTRIBUTORS

Est.1899

At Scattergood & Johnson Ltd, we pride ourselves on being a technical distributor to specialist industries.

Working with a range of quality product suppliers across a number of specialist markets, we are not your average 'box shifter' - we are your technical and supply chain partner.

We fully support every product we sell - for free! Our internal team and external sales engineers can answer any product or application question, no matter the complexity.

Backing up this technical ability is a range of 50,000+ products available from stock for nationwide next day delivery (same day if required!), or you can collect what you need from any of our trade counters around the UK.

Select your specialist interest below to learn more about how we can help.



Online, In Branch and On the Road - Scattergood & Johnson Ltd, there when you need us.

# [www.scatts.co.uk](http://www.scatts.co.uk)