

# SPOOL VALVE

hand or foot operated  
G 1/4

## SPECIFICATIONS

FLUID	: air or neutral gas, filtered, lubricated or not
PORTS	: G 1/4
PRESSURE	: 0 to 10 bar
TEMPERATURE	: -25°C to +60°C
FLOW (Qv at 6 bar)	: 860 l/min (ANR)

## CONSTRUCTION

Environmentally-protected construction  
 Body: treaded aluminium  
 Internal parts: zinc diecasting, steel,  
 stainless steel, acetal (POM)  
 Sealings: nitrile (NBR) and polyurethane (PUR)

For 3/2 NC  
 connection  
 1 = Pressure  
 2 = Outlet  
 3 = Exhaust



## CHOICE OF EQUIPMENT

[Configurator - CAD Files](#)

Symbols functions	Operators		CODES
	Pilot	Return	
<b>LEVER OPERATED</b>			
	Lever - Lever detented		55102088
	Lever	Spring	55102089
<b>PEDAL OPERATED</b>			
	Pedal 2 positions		55102090
	Pedal	Spring	55102091
<b>BUTTON OPERATED</b>			
	Button	Spring	55102082
	Button push-pull		55102083

Note: do not connect the pressure supply to the exhaust port 3. For a "distributing" function or use in NO function, contact us.

These products exist in versions [5/2](#) and [5/3](#)

00403GB-2016/R01  
 Availability, design and specifications are subject to change without notice. All rights reserved.

**DIMENSIONS AND WEIGHTS**

VALVE LEVER OPERATED

Weight: 0,360 kg

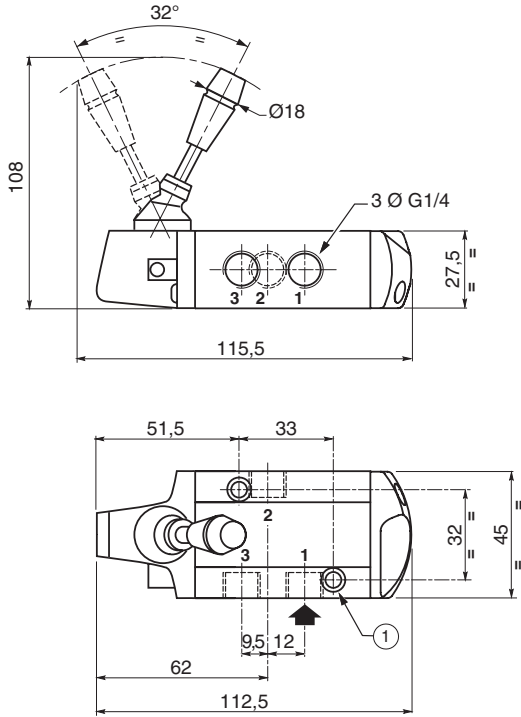

[Configurator - CAD Files](#)

VALVE PEDAL OPERATED

Weight: 0,515 kg

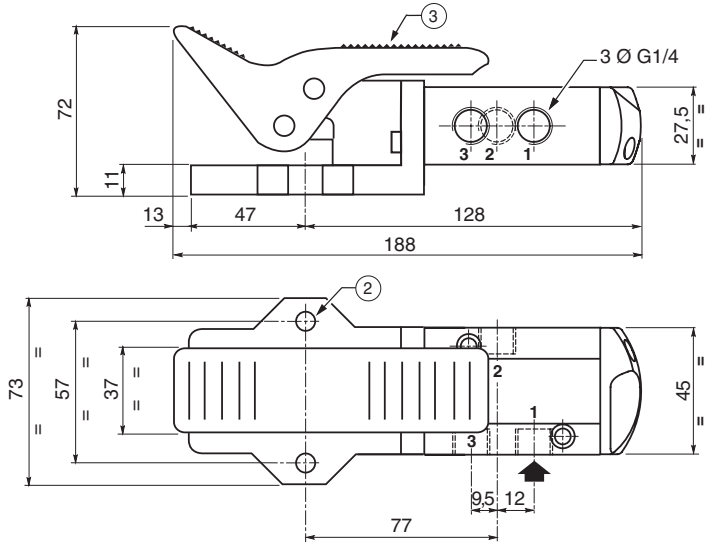

- ① 2 fixing holes : Ø 5,3 - counterbore : Ø 9, dept 5
- ② 2 fixing holes : Ø 8,5
- ③ Return pedal 2 positions

**BUTTON**

BUTTON PUSH-PULL

Weight: 0,230 kg

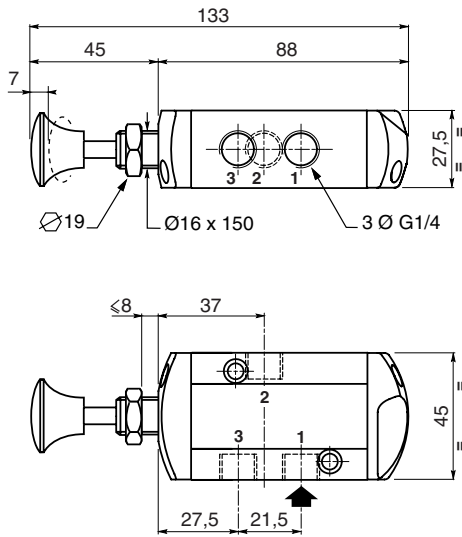



# SCATTERGOOD & JOHNSON LTD

ELECTRICAL ENGINEERING & FLUID CONTROL DISTRIBUTORS

Est.1899

At Scattergood & Johnson Ltd, we pride ourselves on being a technical distributor to specialist industries.

Working with a range of quality product suppliers across a number of specialist markets, we are not your average 'box shifter' - we are your technical and supply chain partner.

We fully support every product we sell - for free! Our internal team and external sales engineers can answer any product or application question, no matter the complexity.

Backing up this technical ability is a range of 50,000+ products available from stock for nationwide next day delivery (same day if required!), or you can collect what you need from any of our trade counters around the UK.

Select your specialist interest below to learn more about how we can help.



Online, In Branch and On the Road - Scattergood & Johnson Ltd, there when you need us.

# [www.scatts.co.uk](http://www.scatts.co.uk)