

ASCO™ Solenoid Valves

Pilot Operated, Floating Diaphragm/Piston, 3/8 to 2

- Two way shut-off valves for automatic control of air, inert gas, water, oil and other gases/liquids compatible with the seal materials used
- Valves require a minimum ΔP of 0,35 bar
- All products are covered by Pressure Equipment Directive 2014/68/EU and are suitable for group 1 and 2 fluids
- The solenoid valves satisfy all relevant EU Directives

General

Differential pressure See «SPECIFICATIONS» [1 bar = 100 kPa]
Maximum viscosity 65 cSt (mm²/s)
Response time 15 - 60 ms (3/8 to 3/4); 40 - 120 ms (1 to 2)

fluids (*)	temperature range (TS)	seal materials (*)
air, inert gas, water, oil	-20°C to +85°C	NBR (nitrile)

Materials in contact with fluid

(*) Ensure that the compatibility of the fluids in contact with the materials is verified

Body Brass / 316L Stainless steel
Shading coil Copper / Silver
Core tube Stainless steel
Core and plugnut Stainless steel
Springs Stainless steel
Seat Brass / 316L Stainless steel
Seal, diaphragm & disc NBR
Piston Brass / st. steel
Piston disc NBR
Disc holder (NO function) PA

Electrical characteristics

Coil insulation class F
Connector Spade plug (cable Ø 6-10 mm)
Connector specification ISO 4400 / EN 175301-803, form A
Electrical safety IEC 335
Electrical enclosure protection Moulded IP65 (EN 60529)
Standard voltages DC (=) : 24V - 48V
 AC (-) : 24V - 48V - 115V - 230V/50 Hz
 (Other voltages and 60 Hz on request)

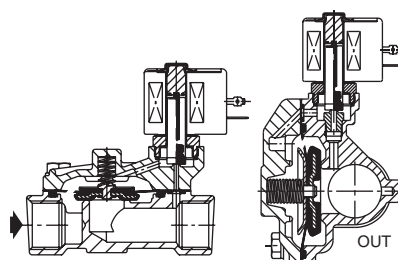
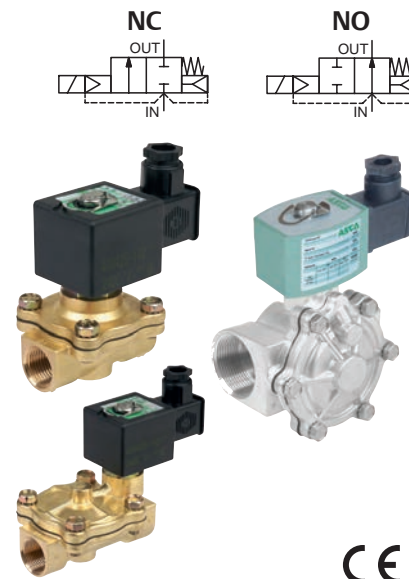

prefix option	power ratings				operator ambient temperature range (TS) (°C)	replacement coil		type ⁽¹⁾
	inrush ~ (VA)	holding ~ (VA) (W)		hot/cold = (W)		~ 230 V/50 Hz	= 24 V DC	
		~ (VA)	~ (W)					
SC	34	15,6	6	-	-20 to +75	400325-117	-	01
	-	-	-	9/ 11,2	-20 to +75	-	400425-142	02
	78	35	16,7	-	-20 to +50	400425-217	-	02
	110	33,6	15,4	12/16,8	-20 to +75	400525-117	400625-142	03
	30	16	8,1	-	-25 to +55	238213-059	-	04
-	-	-	8,5/ 11,6	-25 to +55	-	238913-006	-	05

⁽¹⁾ Refer to the dimensional drawings on the following page.

Specifications

pipe size	orifice size (mm)	flow coefficient Kv (m ³ /h) (l/min)	operating pressure differential (bar)								power coil (W)		Catalog number		options			
			min.	max. (PS)						~	=	brass	stainless steel	maintained man. operator	FPM	EPDM	CR	
				air (*)	water (*)	oil (*)	~	=	~									=
NC - Normally closed																		
3/8	16	2,6 43	0,35	14	9	10	7	10	7	6	11,2	SCE210D001	-	MO	V	E	J	
				20	-	20	-	20	-	16,7	-	SCE210C006	-	MO	V	E	J	
1/2	16	3,4 57	0,35	14	9	10	7	10	7	6	11,2	SCE210D002	-	MO	V	E	J	
				20	-	20	-	20	-	16,7	-	SCE210C007	-	MO	V	E	J	
3/4	19	4,3 72	0,35	9	7	9	6	9	5	6	11,2	SCE210D009	-	MO	V	E	J	
		5,6 93	0,35	17	9	10	9	10	9	6	11,2	SCE210D003	-	MO	V	E	J	
1	25	11,1 185	0,35	9	9	9	9	9	9	6	11,2	SCE210D004	-	MO	V	E	J	
		28 213	0,35	9	9	9	9	9	9	6	11,2	SCE210D008	-	MO	V	E	J	
1 1/4	32	19,3 322	0,35	9	9	9	9	9	9	8,1	11,6	-	SCE210G125	MO	V	E	J	
		32 322	0,35	9	9	9	9	9	9	6	11,2	SCE210D022	-	MO	V	E	J	
1 1/2	32	19,3 322	0,35	9	9	9	9	9	9	6	11,2	SCE210-100 ⁽²⁾	-	MO	V	E	J	
										8,1	11,6	-	SCE210G127	MO	V	E	J	
2	44	37 617	0,35	9	3	9	3	6	3	6	11,2	SCE210-100 ⁽²⁾	-	MO	V	E	J	
										8,1	11,6	-	SCE210G129 ⁽²⁾	MO	V	E	J	

⁽²⁾ Floating piston construction.

00042GB-2019/R02 Availability, design and specifications are subject to change without notice. All rights reserved.

Specifications

pipe size	orifice size	flow coefficient Kv		operating pressure differential (bar)								power coil (W)		Catalog number		options			
				min.	max. (PS)						brass					stainless steel	maintained man. operator	FPM	EPDM
					air (*)	water (*)	oil (*)	air (*)	water (*)	oil (*)									
Rp	(mm)	(m³/h)	(l/min)		~	=	~	=	~	=	~	=							
NO - Normally open																			
3/4	19	5,7	95	0,35	17	17	14	14	14	14	15,4	16,8	SCE210C013	-	MO	V	E	J	
1	25	11,1	185	0,35	9	9	9	9	9	9	15,4	16,8	SCE210D014	-	MO	V	E	J	
1 1/4	28	12,8	213	0,35	9	9	9	9	9	9	15,4	16,8	SCE210D018	-	MO	V	E	J	
	32	19,3	322								15,4	16,8	-	SCE210A131	MO	V	E	J	
1 1/2	32	19,3	322	0,35	9	9	9	9	9	9	15,4	16,8	SCE210D032	SCE210A132	-	V	E	J	
2	44	37	617	0,35	9	9	9	9	9	9	15,4	16,8	SCE210-103 ⁽¹⁾	SCE210A133 ⁽¹⁾	-	V	E	J	

⁽¹⁾ Floating piston construction.

Options

- Valves can also be supplied with FPM (fluoroelastomer), EPDM (ethylene-propylene), CR (chloroprene) and PTFE seals and discs. Use the appropriate optional suffix letter for identification.
- Waterproof enclosure with embedded screw terminal coil according to protection class IP67, CEE-10
- Explosionproof enclosures for use in zones 1/21-2/22, categories 2-3 to ATEX Directive 2014/34/EU ⁽²⁾
- Electrical enclosures according to "NEMA" standards are available
- Compliance with "UL", "CSA" and other local approvals available on request
- For protection against corrosion caused by the environment or the fluid, contact us
- Mounting brackets (3/8 to 3/4 solenoid valves)
- Other pipe connections are available on request
- Connector with visual indication and peak voltage suppression or with cable length of 2 m

⁽²⁾ Please consult the quick selection guide on potentially explosive atmospheres on Emerson.com/asco

Installation

- The solenoid valves can be mounted in any position without affecting operation
- Pipe connection identifier is E = Rp (ISO 7/1)
- Installation/maintenance instructions are included with each valve

Spare parts kit & Accessories

Catalog number	spare parts kit no.		mounting bracket
	~	=	
SCE210G125/G127	C325338	C325365	-
SCE210G129/A131	C325366	C325367	-
SCE210A132	C325368	C325368	-
SCE210A133	C325369	C325369	-
SCE210D001/D002	C302273	C302373	038713-000
SCE210D009	C302277	C302376	038713-000
SCE210C006/C007	C302274	-	038713-000
SCE210D003	C302279	C302378	038914
SCE210D004/D008	C302280	C302379	-
SCE210D022	C302284	C302383	-
SCE210C013	C302336	C302451	038914
SCE210D014/D018	C302338	C302452	-
SCE210D032	C302341	C302453	-
SCE210-100	C304355	C304359	-
SCE210-103	C304361	C304361	-

- Not available

Ordering examples:

SC	E	210	D	001	230V / 50 Hz
SC	E	210	C	007	MO 115V / 50 Hz
SC	E	210	D	022	V 24V / DC
SC	E	210	-	103	230V / 50 Hz

prefix — pipe thread — basic number — voltage — suffix

Ordering examples kits:

C302277 ⁽³⁾	
C302373	V
C302451	E

basic number — suffix

⁽³⁾ Standard prefixes/suffixes are also applicable to kits.

00042GB-2019/R03 Availability, design and specifications are subject to change without notice. All rights reserved.

ASCO™ Solenoid Valves

Dimensions (mm), Weight (kg)



TYPE 01-02
Prefix "SC" Solenoid
Epoxy moulded
IEC 335 / ISO 4400
IP65

Type 01 (AC): SCE210D001/D002/D009
Type 02 (DC): SCE210D001/D002/D009
(AC): SCE210C006/C007

Type 01 (AC): SCE210D003
Type 02 (DC): SCE210D003

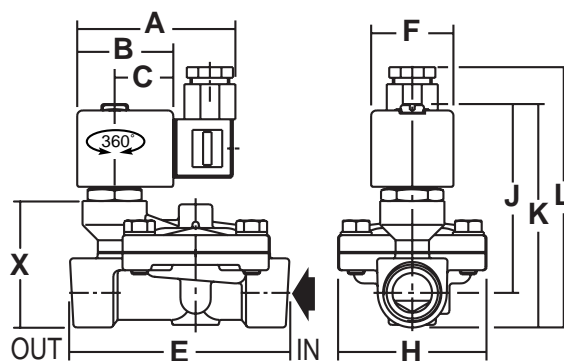
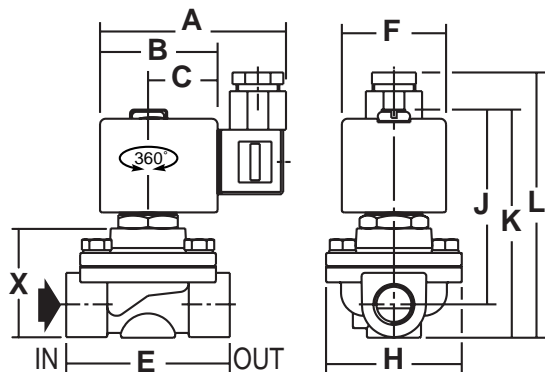

Type 01 (AC): SCE210D004/D008
Type 02 (DC): SCE210D004/D008

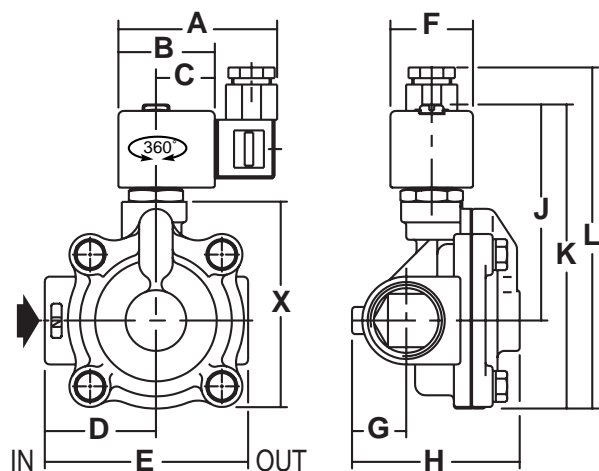

mounting brackets	for valves
	SCE210D001 SCE210D002 SCE210D009 SCE210C006 SCE210C007
	SCE210D003

type	prefix option	Catalog number	A	B	C	D	E	F	G	H	J	K	L	M	X	weight ⁽¹⁾
01	SC	SCE210D001/D002	75	45	27	-	70	39	-	58	72	86	103	-	46	0,8
		SCE210D009	75	45	27	-	71	39	-	58	76	92	109	-	47	0,8
		SCE210D003	75	45	27	-	100	39	-	70	90	105	122	-	60	1,3
		SCE210D004	75	45	27	52	95	39	25	75	101	143	160	-	98	1,8
		SCE210D008	75	45	27	58	115	39	33	99	105	155	172	-	109	2,0
02	SC	SCE210D001/D002	80	50	30	-	70	45	-	58	85	97	111	-	46	0,9
		SCE210D009	80	50	30	-	71	45	-	58	89	106	123	-	57	0,9
		SCE210D003	80	50	30	-	100	45	-	70	94	109	126	-	60	1,4
		SCE210C006/C007	80	50	30	-	70	45	-	58	85	99	116	-	50	0,9
		SCE210D004	80	50	30	52	95	45	25	75	105	147	164	-	98	2,0
SCE210D008	80	50	30	58	115	45	33	99	110	159	175	-	98	2,0		

⁽¹⁾ Incl. coil(s) and connector(s).

00042CB-2019/R02
Availability, design and specifications are subject to change without notice. All rights reserved.

Dimensions (mm), Weight (kg)



TYPE 01-02
Prefix "SC" Solenoid
Epoxy moulded
IEC 335 / ISO 4400
IP65

Type 01 (AC): SCE210D022
Type 02 (DC): SCE210D022

Type 01, AC: SCE210-100
Type 02, DC: SCE210-100

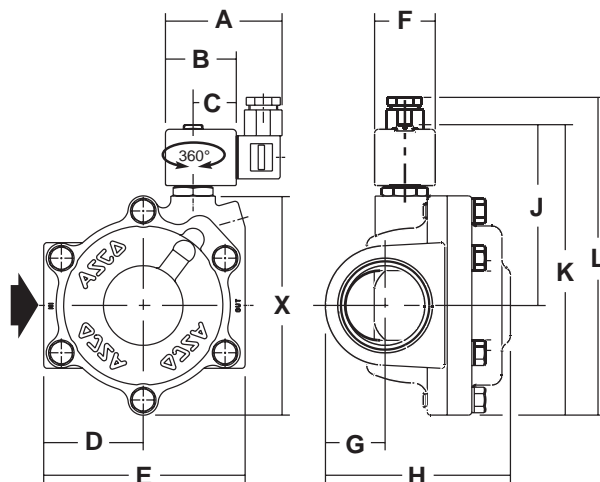
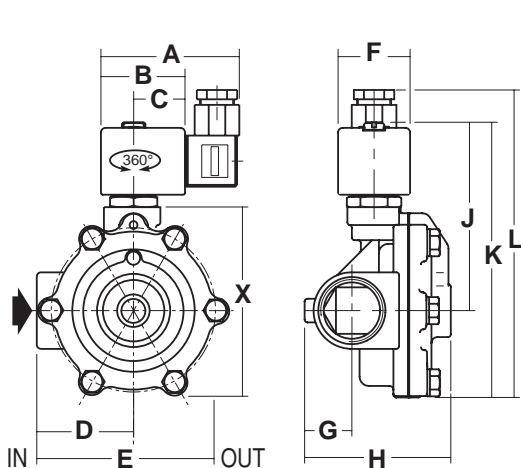

type	prefix option	Catalog number	A	B	C	D	E	F	G	H	J	K	L	M	X	weight ⁽¹⁾
01	SC	SCE210D022	75	45	27	58	115	39	33	99	105	155	172	-	109	2,5
		SCE210-100	75	45	27	64	129	39	39	117	116	186	203	32	140	5,5
02	SC	SCE210D022	80	50	30	58	115	45	33	99	110	159	175	-	109	2,6
		SCE210-100	80	50	30	64	129	45	39	117	120	190	206	32	140	5,5

⁽¹⁾ Incl. coil(s) and connector(s).



TYPE 03
Prefix "SC" Solenoid
Epoxy moulded
IEC 335 / ISO 4400
IP65

SCE210C013

SCE210A131/A132/D014/D018/D032

SCE210-103 / SCE210A133

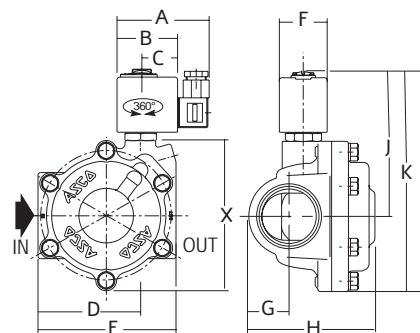
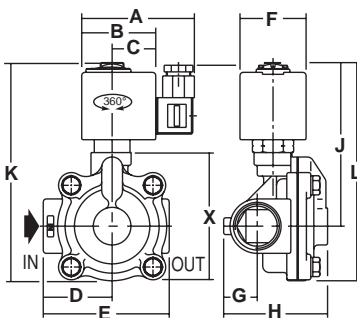
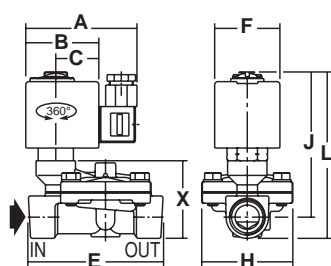

type	prefix option	Catalog number	A	B	C	D	E	F	G	H	J	K	L	M	X	weight ⁽²⁾
03	SC	SCE210C013	91	56	33	-	96	50	-	70	112	-	120	-	81	1,6
		SCE210D014	91	56	33	52	95	50	25	75	125	-	165	-	97	2,1
		SCE210D018	91	56	33	52	95	50	30	85	125	-	165	-	108	2,0
		SCE210D032	91	56	33	56	111	50	33	95	128	-	178	-	121	2,5
		SCE210A131/A132	91	56	33	58	115	50	33	99	128	177	174	-	109	2,7
		SCE210-103	91	56	33	64	129	50	39	117	120	208	205	32	140	4,6
		SCE210A133	91	56	33	64	129	50	39	117	138	208	205	32	140	4,3

⁽²⁾ Incl. coil(s) and connector(s).

mounting brackets	for valves
	SCE210C013

ASCO™ Solenoid Valves

Dimensions (mm), Weight (kg)



TYPE 04-05
Prefix "SC" Solenoid
Epoxy moulded
IEC 335 / ISO 4400
IP65

Type 04 (AC): SCE210G125/127

Type 05 (DC): SCE210G125/127

Type 04 (AC): SCE210G129

Type 05 (DC): SCE210G129

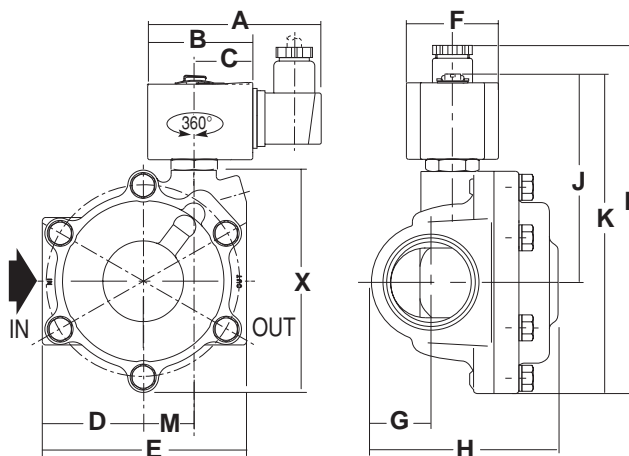
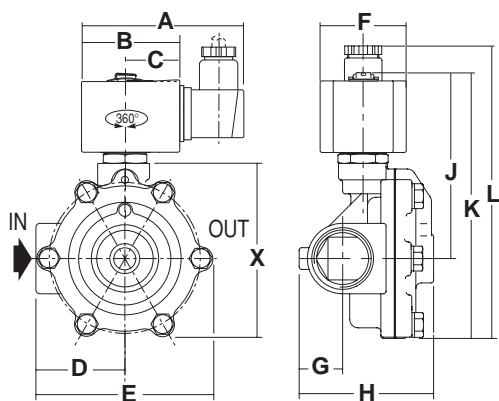

type	prefix option	Catalog number	A	B	C	D	E	F	G	H	J	K	L	M	X	weight ⁽¹⁾
04	SC	SCE210G125 / G127	80	45	28	58	115	39	33	99	105	155	172	-	109	2,4
		SCE210G129	80	45	28	64	129	39	39	117	116	186	203	32	140	4,0
05	SC	SCE210G125 / G127	85	50	30	58	115	45	33	99	110	159	175	-	109	2,6
		SCE210G129	85	50	30	64	129	45	39	117	120	190	206	32	140	4,2

⁽¹⁾ Incl. coil(s) and connector(s)

Series
210

ASCO™ Solenoid Valves

00042GB-2019/R02
Availability, design and specifications are subject to change without notice. All rights reserved.



SCATTERGOOD & JOHNSON LTD

ELECTRICAL ENGINEERING & FLUID CONTROL DISTRIBUTORS

Est.1899

At Scattergood & Johnson Ltd, we pride ourselves on being a technical distributor to specialist industries.

Working with a range of quality product suppliers across a number of specialist markets, we are not your average 'box shifter' - we are your technical and supply chain partner.

We fully support every product we sell - for free! Our internal team and external sales engineers can answer any product or application question, no matter the complexity.

Backing up this technical ability is a range of 50,000+ products available from stock for nationwide next day delivery (same day if required!), or you can collect what you need from any of our trade counters around the UK.

Select your specialist interest below to learn more about how we can help.



Online, In Branch and On the Road - Scattergood & Johnson Ltd, there when you need us.

www.scatts.co.uk