

LBK System **Bus**

3D
SAFETY
RADAR

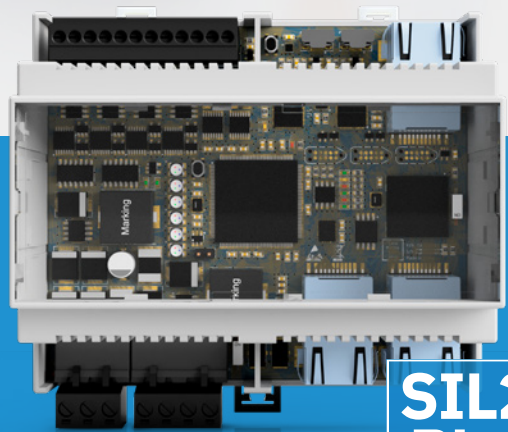

SIL2
PLd
CERTIFIED

WORLD'S FIRST

3D SAFETY RADAR

LBK System Bus

Industrial safety at the highest levels: it detects the access or presence of an operator in a dangerous area allowing real-time dynamic setting of the detection zone, the warning zone, the sensitivity of the system and the input functionality.



LBK-S01

ISC-B01

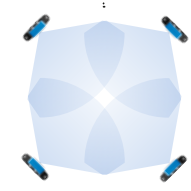
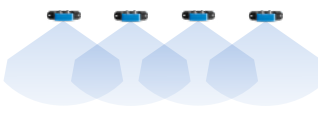
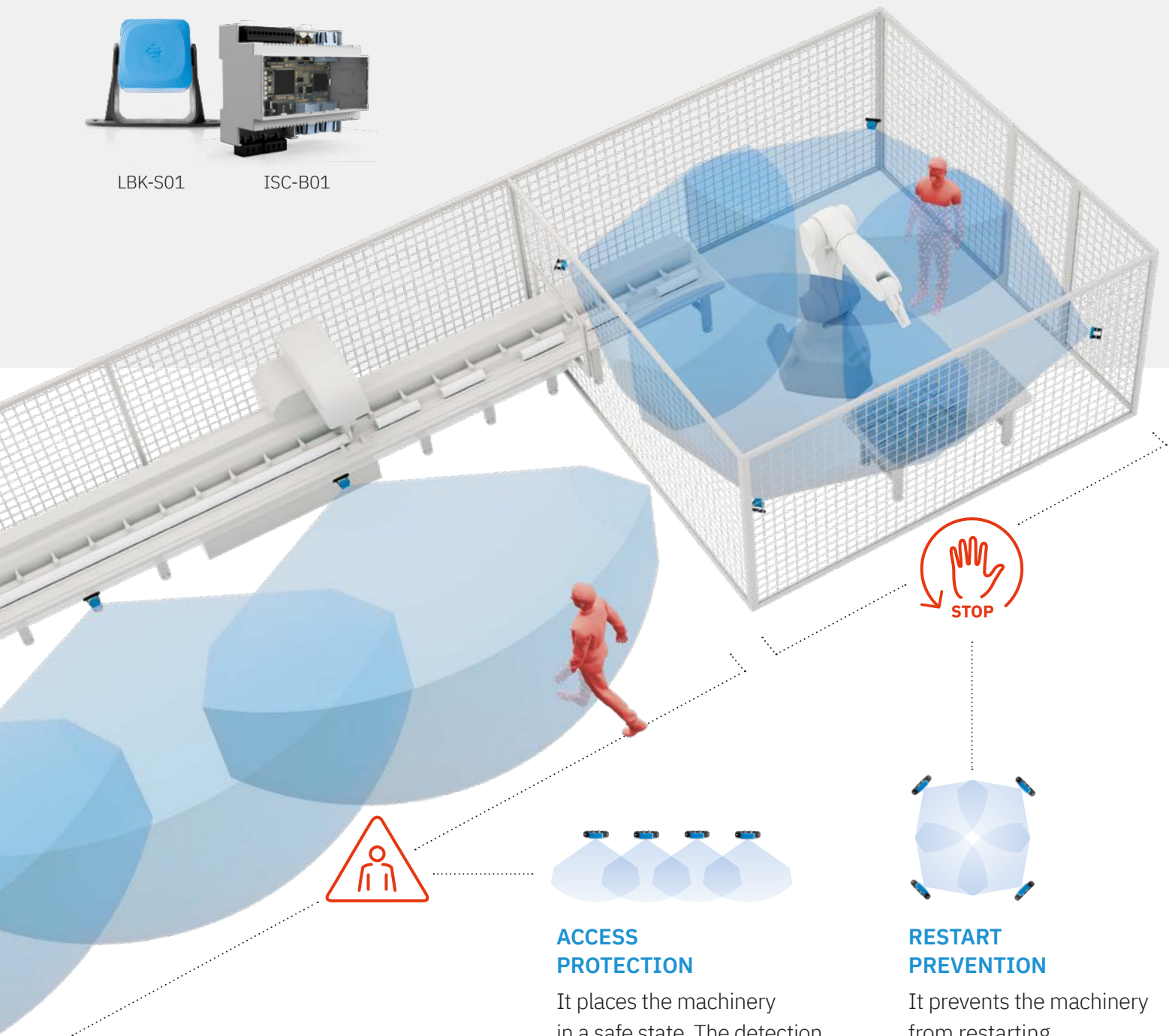

ACCESS PROTECTION

It places the machinery in a safe state. The detection parameters can be dynamically modified in real-time.

RESTART PREVENTION

It prevents the machinery from restarting while operators are in the dangerous area.

**World's first
SIL2/PLd
radar system**



CERTIFIED BY TÜV SUD AS

- **SIL 2** according to IEC 62061
- **PL d, up to Category 3**, according to ISO 13849

**It works where optical
sensors stop.
High safety without
compromising productivity**

Optical devices often fail due to dust, smoke, water or waste generated by the production process. The Inxpect team, highly specialized in radar technology, has developed a sophisticated 24 GHz radar algorithm that filters out those disturbances, reducing false alarms and increasing productivity.

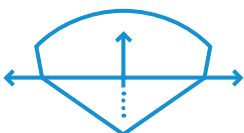
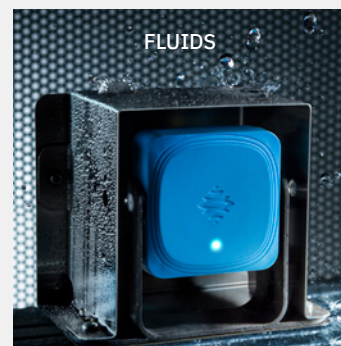

DYNAMIC MODIFICATION OF THE DETECTION ZONE

With ISC-B01 control unit, the system's parameters can be configured in real-time, allowing a dynamic modification of the detection zone.

This feature makes ISC-B01 a perfect solution for Mobile Industrial Robot (MiR) applications.

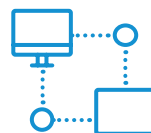

IMPROVE THE COMMUNICATION WITH THE MACHINERY

ISC-B01 ethernet safety fieldbus provides a safety mechanism to communicate with the machinery's PLC. The fieldbus can exchange complex information in real-time, such as the position of the target, and allows a quick integration with the machinery's control system.



REMOTE CONFIGURATION

The ethernet communication guarantees more flexibility, easier integration and the possibility of a remote access for the system configuration. The communication with the ISC-B01 is secured by the most advanced security protocols.

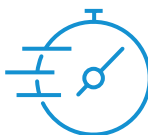

RESPONSE TIME < 100ms

With a response time lower than 100 ms, you can save space and reduce the area required to stop the machinery.

INXPECT
SAFETY APPLICATION



ISC-B01

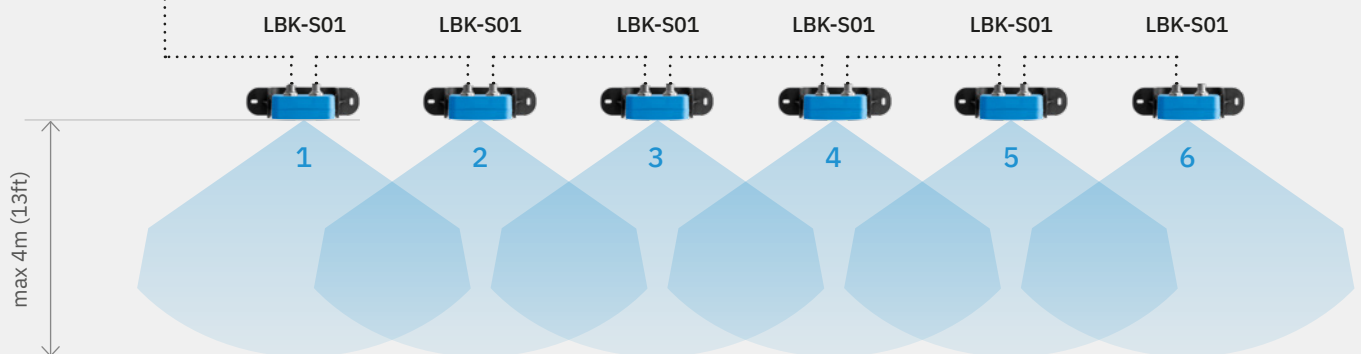
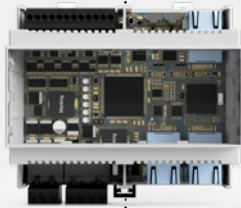

Easy setup

The LBK System is composed of the **ISC-B01** control unit and up to six **LBK-S01** sensors. The maximum depth of the monitored area is 4m (13ft).

Configuring the system is quick and easy, thanks to the user friendly **Inxpect Safety Application**. Guided validation procedures and the simple generation of the configuration report complete the installation.



A perfect alignment between sensors is not required.



The provided Inxpect Safety Application allows multiple configuration modes: automatic for regular-shaped areas, manual for the monitoring of more complex areas.



Programmable Muting function: the configuration of sensor groups that can be temporarily muted allows operators to safely access parts of the dangerous area, according to production needs.

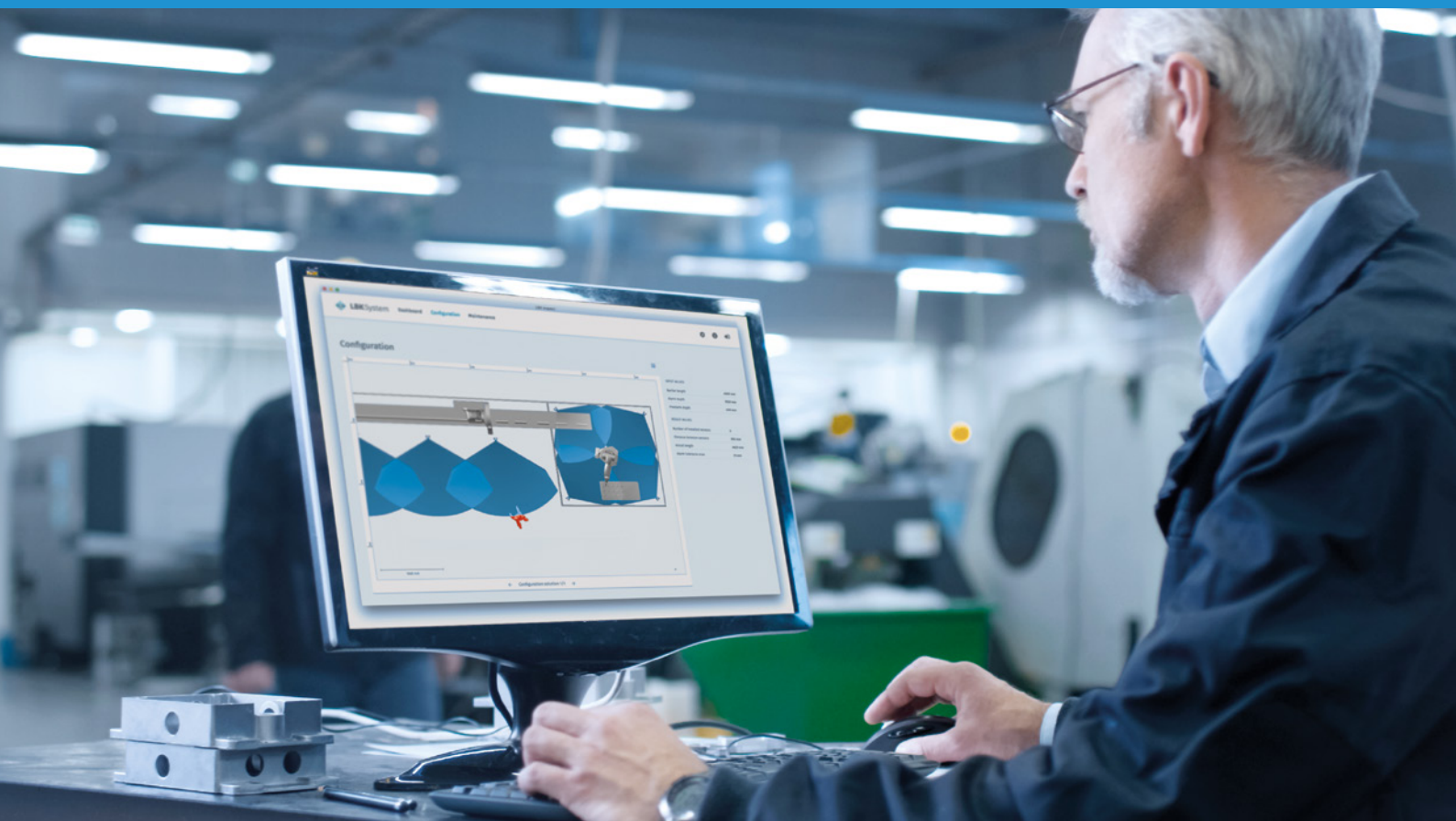

Sensing field

Each LBK-S01 sensor in the LBK System can be field-programmed, independently from the others, to cover either a Wide or a Narrow sensing field. The actual covered area of each sensor depends on installation height and tilt.

WIDE COVERAGE FIELD

Horizontal Plane: 110°
Vertical Plane: 30°

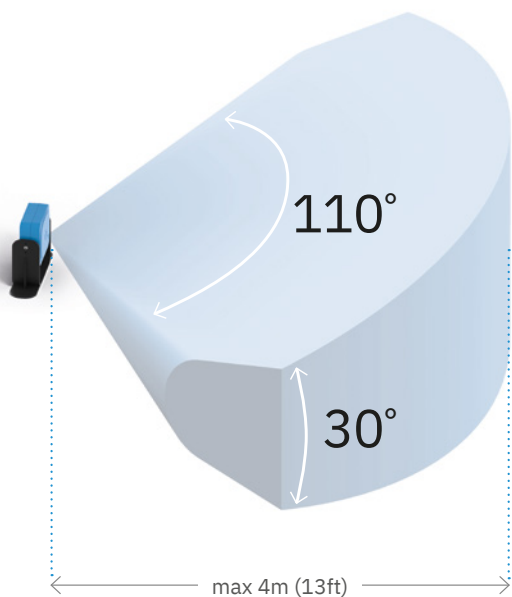

NARROW COVERAGE FIELD

Horizontal Plane: 50°
Vertical Plane: 15°

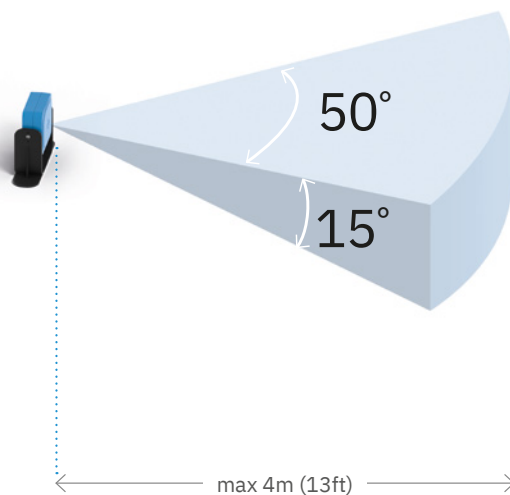



Complies with
INDA Standards
DA103787

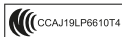

ICASA TA 2019-5126
APPROVED



LBK-S01

The smart radar sensor

The **LBK-S01** sensor is a smart FMCW (Frequency Modulated Continuous Wave) radar device based on proprietary Inxpect detection algorithms. The sensor sends 24 GHz radio waves and recovers motion information, analyzing the returned signals reflected by both static and moving objects in the operative range.

The sensors perform the following primary functions:

- **Motion and scenario analysis.**
- **Communication via CAN bus to the controller of the motion detection signal.**
- **Fault reporting and communication of diagnostic information via CAN bus to the controller.**



out in

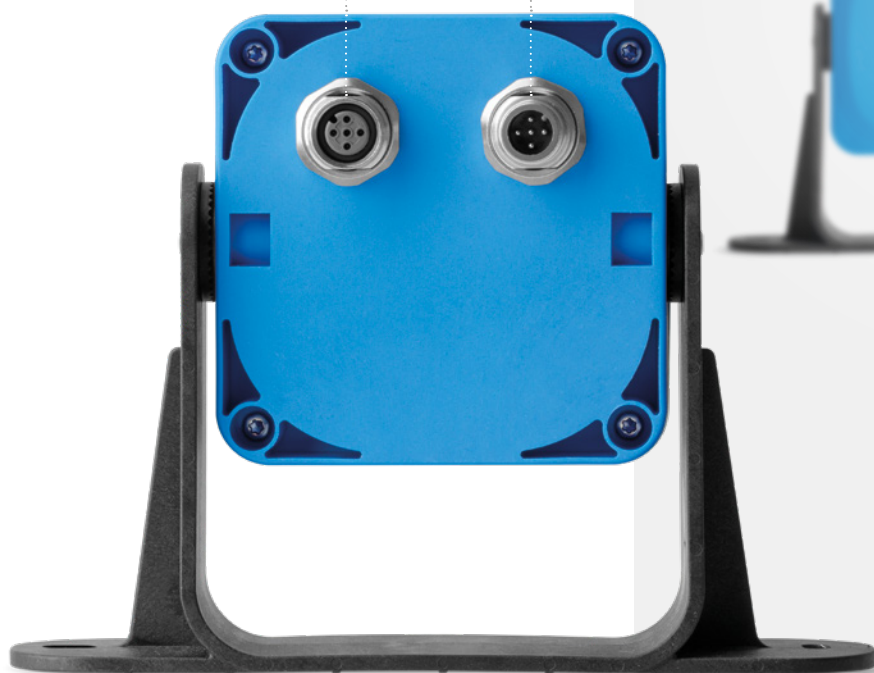



ISC-B01

The control unit

ISC-B01 is the new control unit for the Inxpect radar detection system, which improves the performance of the system providing advanced functionality through the ethernet connection:

- **ISC-B01 can be remotely configured using the Inxpect Safety Application: the security is guaranteed by the adoption of the highest security standards.**
- **The detection zone can be dynamically modified in real-time.**
- **The sensitivity of the system, the warning zone and the input functionality can be dynamically configured.**
- **It supports different fieldbus protocols (e.g. ProfiSafe, CIP Safety).**

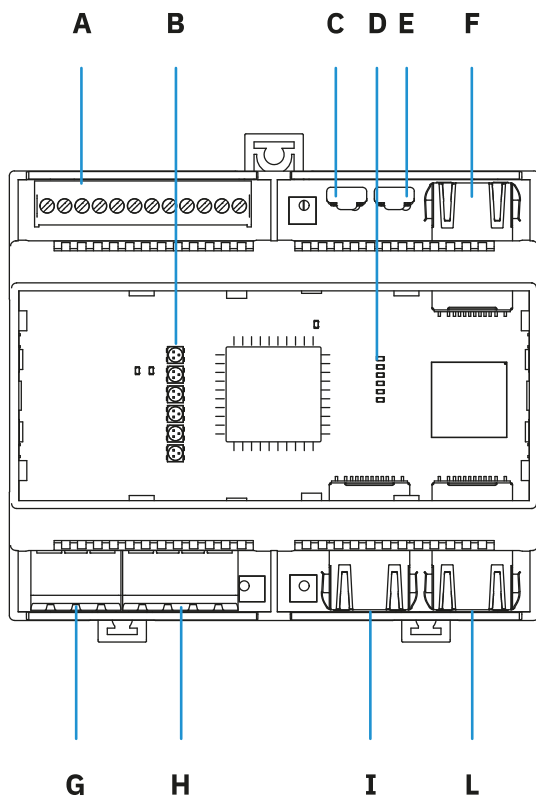
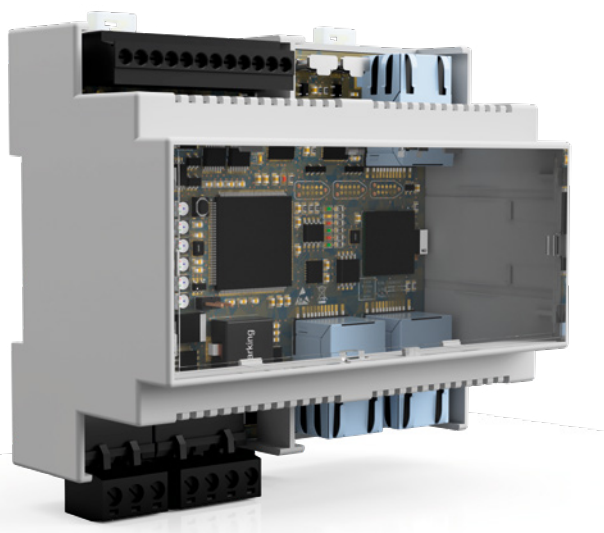

- A** - I/O Connector
- B** - Sensor's status LED
- C** - Micro USB port for the communication with the Inxpect Safety App
- D** - Ethernet fieldbus' status LED
- E** - Micro USB port (reserved)
- F** - Ethernet port for the communication with the Inxpect Safety App
- G** - Power supply connector
- H** - CAN bus and sensor power supply connector
- I** - Ethernet fieldbus port n. 1
- L** - Ethernet fieldbus port n. 2

Dimensions

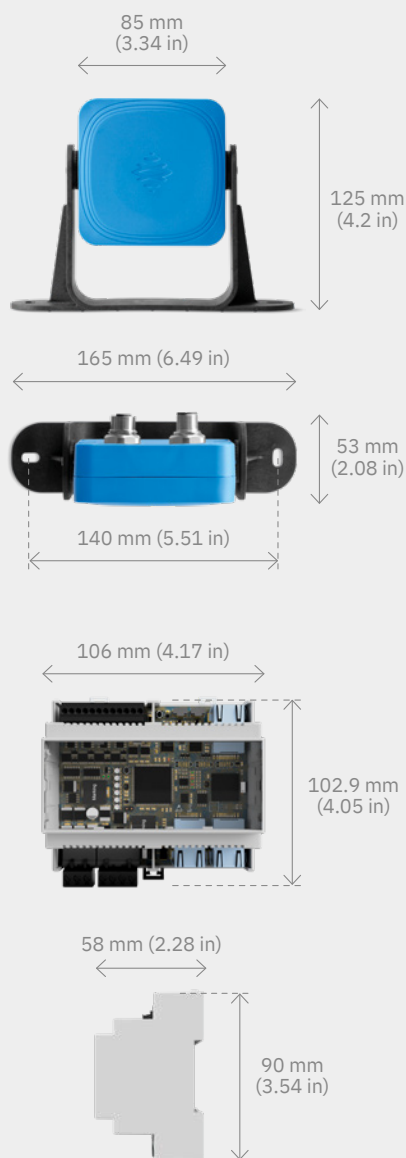

Conformity



Directives 2006/42/EC (MD - Machinery)
2014/53/EU (RED - Radio equipment)

Standards IEC/EN 62061: 2005 SIL 2
EN ISO 13849-1: 2015 PL d
EN ISO 13849-2: 2012
IEC/EN 61496-1: 2013
IEC/EN 61508: 2010 Part 1-7 SIL 2
ETSI EN 300 440 v2.1.1
ETSI EN 301 489-1 v2.2.0 (only emissions)
ETSI EN 301 489-3 v2.1.1 (only emissions)
IEC/EN 61326-3-1: 2017
IEC/EN 61010-1: 2010

General

Detection method	Inxpect motion detection algorithm based on FMCW radar
Frequency	Working band: 24–24,25 GHz (24.05–24.25 for UK and FR) Transmission power: ≤ 13 dBm - Modulation: FMCW
Detection interval	From 1 to 4 m (0 to 13.1 ft), depending on the installation conditions
Sensing field and Installation height	Wide FOV configuration: 110° Horiz. 30° Vert., Height: 0 to 3 m (0 to 9.8 ft) Narrow FOV configuration: 50° Horiz. 15° Vert., Height: 0 to 3 m (0 to 9.8 ft)
Guaranteed response time	< 100 ms
SIL (Safety Integrity Level)	2
PL (Performance Level)	d
Category	2 with sensors in 1oo1 configuration; 3 with sensors in 1oo2 configuration
Total consumption	12 W (controller and six sensors)
Operating Temperature	From -30 to +60 °C (-22 to +140 °F)
Storage Temperature	From -40 to +80 °C (-40 to +176 °F)
Communication protocol (sensors-controller)	CAN complies with standard EN 50325-5
Warranty period	36 months from the date of purchase of the product

Sensor

Connectors	2 5-pin M12 connectors (1 male and 1 female)
CAN bus termination resistance	120 Ω (not supplied, to be installed with termination connector)
Power supply	12 V dc ± 20%, through controller
Degree of protection	IP67
Material	Sensor case: PA66 Bracket: PA66 and glass fiber (GF)

Controller

Outputs	4 Outputs Signal Switching Devices (OSSDs) 2 dual channel safety outputs
Safety outputs	High-side outputs (with extended protection function) Max voltage: 30 V dc Max current: 0,4 A Max power: 12 W
Inputs	2 dual channel TYPE3 digital inputs with common GND
Fieldbus interface	Ethernet based interface with different standard fieldbus (e.g. ProfiSafe)
Power supply	24 V dc (20–28 V dc) Max current: 0.6A
Consumption	Max 5 W
Category	3
Assembly	DIN guide
Degree of protection	IP20
Terminals	Section: 1 mm ² (AWG16) Max Current: 4A with 1 mm ² cables

CAN bus cables

Section	2 x 0,25 mm ² (AWG24) for data signal and 2 x 0,25 mm ² (AWG24) for power supply
Type	4 wires and 1 drain wire (or shield)
Connectors	5-pole M12
Impedance	120 Ω ± 10% (f = 1MHz)
Shield	Shield with twisted wires in tin-plated copper. Requires ground connection.
Length	30 m (98.4 ft) from controller to sensor (configuration with 1 sensor)



SCATTERGOOD & JOHNSON LTD

ELECTRICAL ENGINEERING & FLUID CONTROL DISTRIBUTORS

Est.1899

At Scattergood & Johnson Ltd, we pride ourselves on being a technical distributor to specialist industries.

Working with a range of quality product suppliers across a number of specialist markets, we are not your average 'box shifter' - we are your technical and supply chain partner.

We fully support every product we sell - for free! Our internal team and external sales engineers can answer any product or application question, no matter the complexity.

Backing up this technical ability is a range of 50,000+ products available from stock for nationwide next day delivery (same day if required!), or you can collect what you need from any of our trade counters around the UK.

Select your specialist interest below to learn more about how we can help.



Online, In Branch and On the Road - Scattergood & Johnson Ltd, there when you need us.

www.scatts.co.uk