

# Metallic (Exd/Exe) adaptors and reducers – AD-U / RD-U Series

## Technical specification

Redapt AD-U and RD-U series of explosion-proof metallic adaptors and reducers provide a method of matching electrical thread forms on hazardous area approved equipment whilst ensuring the integrity and Ex approval of the installation is maintained.

Manufactured from hexagon material to facilitate easy installation, they are also supplied complete with a captive O-ring seal. The O-ring is located within a recess on the face of the product, helping to protect the O-ring from the environmental damage and ensuring it is not displaced during installation.

Designed for hazardous area applications and the range is certified to protection concepts Exd "Flameproof" and Exe "Increased Safety" for use in Zone 1 and Zone 2 applications. Also certified Ex tb "dust tight" for use in Zone 21 & 22 applications.



Type AD-U



Type RD-U

## Certifications and compliances



### Code of protection categories

<b>ATEX:</b>	I M2/II 2 GD
<b>IECEX:</b>	Ex db I/IIC Mb/Gb, Ex eb I/IIC Mb/Gb, Ex tb IIIC Db (Aluminium not mining)
<b>CSA:</b>	RD-U Ex db / Ex eb IIC Gb IP66/67/68; CI I Zn 1 AEx eb / AEx db IIC Gb IP54; CI I Div1 Gr ABCD CI II Gr EFG CI III; Type 3 AD-U Ex db / Ex eb IIC Gb IP66/67/68; CI I Zn 1 AEx eb / AEx db IIC Gb IP54; CI I Div1 Gr ABCD CI II Gr EFG CI III; Type 3

### Compliance standards

<b>ATEX:</b>	EN 60079-0, EN 60079-1, EN 60079-7, EN 60079-31
<b>IECEX:</b>	IEC 60079-0, IEC 60079-1, IEC 60079-7, IEC 60079-31
<b>CSA:</b>	CAN/CSA C22.2 No. 60079-0, No. 60079-1, No. 60079-7, ANSI/UL 60079-0, 60079-1, 60079-7, UL1203

### Certificate details

<b>ATEX:</b>	ITS16ATEX101339X
<b>IECEX:</b>	IECEX ITS 16.0013X
<b>CSA:</b>	CSA01CA1248014X
<b>EAC:</b>	RU C-GB.M062.B.06225
<b>CCoE:</b>	P362565/1 (AD-U) ; P485509 (RD-U)
<b>INMETRO:</b>	NCC 18.0133 X

### Ingress protection (IP):

IP64 when fitted without sealing washer. IP66/IP68 when fitted with O-ring or thread sealant according to manufacturer's instructions.

### Temperature

Temperature will depend on the type of O-ring used:

None:	-60°C to ~ +200°C
Nitrile:	-30°C to +80°C (supplied as standard)
EPDM:	-50°C to +100°C
Neoprene:	-40°C to +80°C
Viton:	-20°C to +180°C
Silicone:	-60°C to +180°C
Fluorosilicone:	-60°C to +130°C

The maximum temperature is limited to +150°C for Group I applications

### Plating options

Electroless nickel  
Zinc  
Chromated  
Others on application

### Threadforms

Metric  
NPT  
Pg  
ISO Pipe (BSP)  
ET

Note : stainless steel may not have the roll marking collar.

# Metallic (Exd/Exe) adaptors and reducers - Dimensions

AD-U

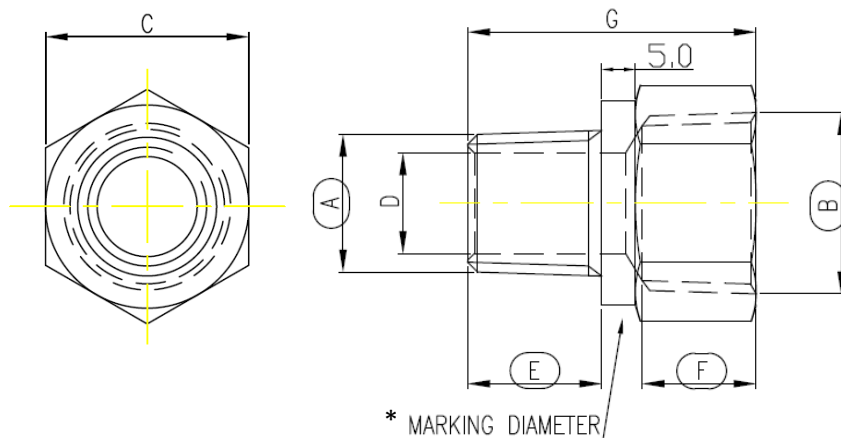

A	B	C	D	E	F	G
Male	Female	A/F	Bore	Thread length	Thread depth	Total length
M16	M16	23.4	10.0	16.0	17.0	38.5
	M20	23.4	10.0	16.0	17.0	38.5
M20	M20	27.0	14.0	16.0	17.0	38.5
	M25	30.5	14.0	16.0	17.0	38.5
M25	M25	31.8	18.0	16.0	17.0	38.5
	M32	37.6	18.0	16.0	17.0	38.5
M32	M32	37.6	24.0	16.0	17.0	38.5
	M40	47.2	24.0	16.0	17.0	38.5
M40	M40	47.2	32.0	16.0	16.5	38.5
	M50	55.9	32.0	16.0	17.0	39.5
M50	M50	57.2	41.0	16.0	17.0	39.5
	M63	70.1	41.0	16.0	17.0	39.5
M63	M63	70.1	53.0	16.0	17.0	39.5
	M75	90.2	53.0	16.0	17.0	39.5
M75	M75	90.2	64.0	16.0	16.5	39.5
	M90	106.4	64.0	16.0	22.0	45.0
M90	M90	106.4	78.0	20.0	22.0	49.0
	M100	114.3	78.0	20.0	22.0	49.0
M100	M100	114.3	88.0	20.0	22.0	49.0

A	B	C	D	E	F	G
Male	Female	A/F	Bore	Thread length	Thread depth	Total length
1/2 NPT	1/2 NPT	23.4	15.0	20.0	20.0	46.0
	3/4 NPT	30.5	15.0	20.0	20.0	46.0
3/4 NPT	3/4 NPT	30.5	19.0	20.0	20.0	46.0
	1 NPT	37.6	19.0	20.0	25.0	51.0
1 NPT	1 NPT	37.6	25.0	25.0	25.0	56.0
	1.1/4 NPT	47.2	25.0	25.0	25.0	56.0
1.1/4 NPT	1.1/4 NPT	47.2	32.0	25.0	25.0	56.0
	1.1/2 NPT	55.9	32.0	25.0	25.0	57.0
1.1/2 NPT	1.1/2 NPT	55.9	38.0	25.0	25.0	57.0
	2 NPT	70.1	38.0	25.0	25.0	57.0
2 NPT	2 NPT	70.1	49.0	25.0	25.0	57.0
	2.1/2 NPT	80.0	49.0	25.0	35.0	67.0
2.1/2 NPT	2.1/2 NPT	80.0	60.0	35.0	35.0	77.0
	3 NPT	106.4	60.0	35.0	35.0	77.0
3 NPT	3 NPT	106.4	75.0	35.0	35.0	77.0
	3.1/2 NPT	114.3	75.0	35.0	35.0	78.0
3.1/2 NPT	4 NPT	127.0	75.0	35.0	35.0	78.0
	3.1/2 NPT	114.3	88.0	35.0	35.0	78.0
4 NPT	4 NPT	127.0	88.0	35.0	35.0	78.0
	4 NPT	127.0	100.0	35.0	35.0	78.0

\* Note : stainless steel may not have the roll marking diameter.

# Metallic (Exd/Exe) adaptors and reducers - Dimensions

RD-U

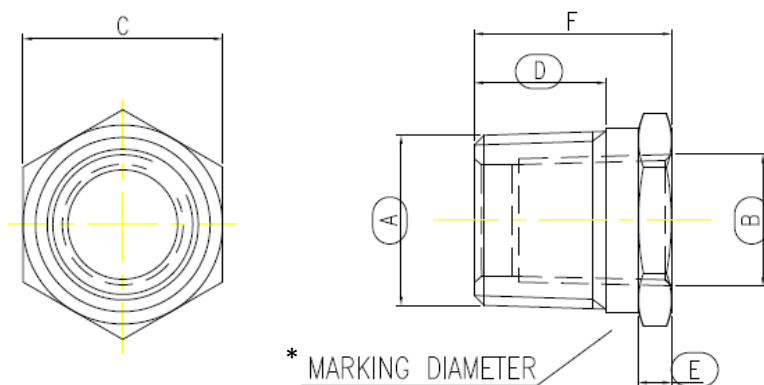

A	B	C	D	E	F
Male	Female	A/F	Thread length	Hexagon length	Total length
M20	M16 & below	27.0	16.0	5.0	26.0
M25	M20 & below	31.8	16.0	5.0	26.0
M32	M25 & below	37.6	16.0	5.0	26.0
M40	M32 & below	47.2	16.0	5.0	26.0
M50	M40 & below	57.2	16.0	6.0	27.0
M63	M50 & below	70.1	16.0	6.0	27.0
M75	M63 & below	90.2	16.0	6.0	27.0
M80	M75 & below	90.2	20.0	6.0	31.0
M85	M75 & below	106.4	20.0	6.0	31.0
M90	M80 & below	106.4	20.0	6.0	31.0
M100	M90 & below	114.3	20.0	6.0	31.0
M110	M90 & below	120.7	20.0	7.0	32.0

A	B	C	D	E	F
Male	Female	A/F	Thread length	Hexagon length	Total length
3/4 NPT	1/2 NPT & below	27.9	20.0	5.0	30.0
1 NPT	3/4 NPT & below	34.9	25.0	5.0	35.0
1.1/4 NPT	1 NPT & below	44.5	25.0	5.0	35.0
1.1/2 NPT	1.1/4 NPT & below	52.1	25.0	5.0	35.0
2 NPT	1.1/2 NPT & below	61.2	25.0	6.0	36.0
2.1/2 NPT	2 NPT & below	80.0	35.0	6.0	46.0
3 NPT	2.1/2 NPT & below	90.2	35.0	6.0	46.0
3.1/2 NPT	3 NPT & below	106.4	35.0	6.0	46.0
4 NPT	3.1/2 NPT & below	120.7	35.0	7.0	47.0

\*Note : stainless steel may not have the roll marking diameter.

# Metallic (Exd/Exe) adaptors and reducers - Product coding

Product	DIGITS 1 & 2
Exd/Exe ADAPTOR	AD
Exd/Exe REDUCER	RD

Certification	DIGIT 3
U	Exd I and IIC & Exe I and IIC

Material	DIGIT 4
1	Brass
2	Mild steel
3	Stainless steel
5	Aluminium

Plating	DIGIT 5
0	Unplated
1	Electroless nickel
2	Zinc
6	Chromated

DIGITS 6 & 7 Male thread ; DIGITS 8 & 9 Female thread							
Metric	ET imperial conduit	NPT	NPSM	ISO pipe parallel (BSPP)	ISO pipe taper (BSPT)	PG	
02 M12							
03 M16	17 5/8" ET	29 1/2" NPT	42 1/2" NPSM	55 1/2" BSPP	68 1/2" BSPT	79	PG7
04 M20	18 3/4" ET	30 3/4" NPT	43 3/4" NPSM	56 3/4" BSPP	69 3/4" BSPT	80	PG9
05 M25	19 1" ET	31 1" NPT	44 1" NPSM	57 1" BSPP	70 1" BSPT	81	PG11
06 M32	20 1 1/4" ET	32 1 1/4" NPT	45 1 1/4" NPSM	58 1 1/4" BSPP	71 1 1/4" BSPT	82	PG13.5
07 M40	21 1 1/2" ET	33 1 1/2" NPT	46 1 1/2" NPSM	59 1 1/2" BSPP	72 1 1/2" BSPT	83	PG16
08 M50	22 2" ET	34 2" NPT	47 2" NPSM	60 2" BSPP	73 2" BSPT	84	PG21
09 M63	23 2 1/2" ET	35 2 1/2" NPT	48 2 1/2" NPSM	61 2 1/2" BSPP	74 2 1/2" BSPT	85	PG29
10 M75	24 3" ET	36 3" NPT	49 3" NPSM	62 3" BSPP	75 3" BSPT	86	PG36
11 M80 x 2.0	ET Special	37 3 1/2" NPT	50 3 1/2" NPSM	63 3 1/2" BSPP	76 3 1/2" BSPT	87	PG42
12 M85 x 2.0		38 4" NPT	51 4" NPSM	64 4" BSPP	77 4" BSPT	88	PG48
13 M90 x 2.0		NT Special	NS Special	BP Special	BT Special		PG Special
14 M100 x 2.0							
15 M110 x 2.0							
BZ M120 x 2.0							

## Example

Digits 1 & 2	Digit 3	Digit 4	Digit 5	Digits 6 & 7	Digits 8 & 9
AD	- U	- 1	- 1	- 29	- 04
Adaptor	Exd/e certified	Brass	Nickel-plated	1/2" NPT (male)	M20 (female)

Always quote male thread first.

Note: threadform codes below to be used for both male and female threads.



## Adaptors and reducers series - selection guide

STEP 2 – Having obtained the reference number, go to the relevant column within the dimension tables to obtain the adaptor or reducer's dimensions. Please note that these dimensions refer to metallic products only.

### Adaptors

#### Metric x metric, metric x PG, PG x metric, PG x PG

Reference numbers	201	202	203	204	205	206	207	208	209	210	211	212	213	214	215	216	257	258	259
Hex across flats	23.4	27.0	30.5	33.0	36.0	37.6	37.6	47.2	55.9	61.2	70.1	90.2	106.4	106.4	114.3	23.4	31.8	41.3	57.2
Hex across corners	26.8	31.0	35.0	38.0	41.5	43.2	43.2	53.4	64.3	70.4	81.8	103.7	122.4	122.4	131.4	26.8	36.1	47.7	66.0
Male thread length	16	16	16	16	16	16	16	16	16	16	16	16	16	20	20	15	16	16	16
Female thread length	17	17	17	17	17	17	17	17	17	17	17	17	22	22	22	20	17	17	17
Total length	38.5	38.5	38.5	38.5	38.5	38.5	38.5	38.5	39.5	39.5	39.5	39.5	45.0	49.0	49.0	42.0	38.5	38.5	39.5

#### Metric x NPT, PG x NPT

Reference numbers	217	218	219	220	221	222	223	224	225	226	227	228	229	230	231	261	262	263	-
Hex across flats	27.0	30.5	32.0	37.6	37.6	41.3	47.2	55.9	57.2	70.1	80.0	106.4	106.4	114.3	127.0	90.2	120.7	139.7	-
Hex across corners	31.0	35.0	36.7	43.2	43.2	47.5	53.4	64.3	66.0	81.8	92.0	122.4	122.4	131.4	147.0	104.1	139.4	161.3	-
Male thread length	16	16	16	16	16	16	16	16	16	16	16	16	16	16	16	20	20	-	-
Female thread length	20	20	20	20	25	25	26	26	26	27	40	35	42	42	44	22	22	22	-
Total length	42	42	42	42	47	47	47	48	48	48	58	58	62	62	62	48	48	49	-

#### NPT x metric, NPT x PG

Reference numbers	232	233	234	235	236	237	238	239	240	241	242	243	244	260	265	-	-	-	-
Hex across flats	23.4	28.6	30.5	37.6	37.6	44.5	55.9	70.1	70.1	90.2	90.2	106.4	114.3	90.2	33.0	-	-	-	-
Hex across corners	26.8	32.9	35.0	43.2	43.2	51.1	64.3	70.4	81.8	103.7	103.7	122.4	131.4	103.7	38.0	-	-	-	-
Male thread length	20	20	20	20	25	25	25	25	25	25	35	35	35	16	20	-	-	-	-
Female thread length	17	17	17	17	17	17	17	17	17	17	17	22	22	35	77	-	-	-	-
Total length	43	43	43	43	48	48	49	49	49	49	59	64	64	58	43	-	-	-	-

#### NPT x NPT

Reference numbers	245	246	247	248	249	250	251	252	253	254	255	256	264	-	-	-	-	-	-
Hex across flats	23.4	30.5	37.6	37.6	47.2	55.9	70.1	80.0	80.0	106.4	114.3	127.0	158.8	-	-	-	-	-	-
Hex across corners	26.8	35.0	43.2	43.2	53.4	64.3	81.8	92.0	92.0	122.4	131.4	146.0	183.3	-	-	-	-	-	-
Male thread length	20	20	20	25	25	25	25	25	35	35	35	35	35	-	-	-	-	-	-
Female thread length	20	20	25	25	25	25	25	35	35	35	35	35	47	-	-	-	-	-	-
Total length	46	46	51	56	56	57	57	67	77	77	78	78	81	-	-	-	-	-	-

### Reducers

#### Metric and PG

Reference numbers	301	302	303	304	305	306	307	308	309	310	311	312	313	324	325	326	-	-	-
Hex across flats	27.0	30.5	31.8	36.0	37.6	44.5	47.2	55.9	57.2	70.1	90.2	106.4	114.3	61.2	120.7	127.0	-	-	-
Hex across corners	31.0	35.0	36.7	41.5	43.2	51.1	53.4	64.3	66.0	81.8	103.7	122.4	131.0	70.7	139.4	146.6	-	-	-
Male thread length	16	16	16	16	16	16	16	16	16	16	16	20	20	16	16	16	-	-	-
Total length	26	26	26	26	26	26	26	27	27	27	27	31	31	27	28	28	-	-	-

#### NPT

Reference numbers	314	315	316	317	318	319	320	321	322	323	327	-	-	-	-	-	-	-	-
Hex across flats	23.4	27.9	34.9	44.5	52.1	61.2	80.0	90.2	106.4	120.7	146.0	-	-	-	-	-	-	-	-
Hex across corners	26.8	32.1	40.2	51.1	59.9	70.4	92.0	103.7	122.4	138.8	168.6	-	-	-	-	-	-	-	-
Male thread length	20	20	25	25	25	25	35	35	35	35	35	-	-	-	-	-	-	-	-
Total length	30	30	35	35	35	36	46	46	46	47	47	-	-	-	-	-	-	-	-

# Thread dimension chart

## ISO metric

BS 3643 1.5mm pitch

Size	Major dia.	TPI
M12	11.97	16.93
M16	15.97	16.93
M20	19.97	16.93
M25	24.97	16.93
M32	31.97	16.93
M40	39.97	16.93
M50	49.97	16.93
M63	62.97	16.93
M75	74.97	16.93
2.0mm pitch		
M80	79.97	12.70
M85	84.97	12.70
M90	89.97	12.70
M100	99.97	12.70
M110	109.97	12.70
M120	119.97	12.70

## Alternate ISO pipe thread designations

UK	<b>BSP Parallel or Taper</b> BS2279 (BS21)
Europe	<b>G</b> (Parallel) <b>GK</b> (Taper) <b>R</b> (Parallel) <b>RK</b> (Taper)
Japan	<b>PF</b> (Parallel) JIS B 303
CIS	<b>K mpy</b> (Taper)

## NPT

ANSI.ASME B1.20.1

Size	Pipe dia.	TPI
1/2"	21.34	14.00
3/4"	26.67	14.00
1"	33.40	11.50
1 1/4"	42.16	11.50
1 1/2"	48.26	11.50
2"	60.33	11.50
2 1/2"	73.03	8.00
3"	88.90	8.00
3 1/2"	101.60	8.00
4"	114.30	8.00

## PG

DIN 40430

Size	Major dia.	TPI
PG7	12.50	20.00
PG9	15.20	18.00
PG11	18.60	18.00
PG13.5	20.40	18.00
PG16	22.50	18.00
PG21	28.30	16.00
PG29	37.00	16.00
PG36	47.00	16.00
PG42	54.00	16.00
PG48	59.30	16.00

## BSP ISO pipe thread

ISO R/7; UNI 6125

Size	Pipe Dia.	TPI
3/8"	16.66	19.00
1/2"	20.96	14.00
3/4"	26.44	14.00
1"	33.25	11.00
1 1/4"	41.91	11.00
1 1/2"	47.80	11.00
2"	59.61	11.00
2 1/2"	75.18	11.00
3"	87.88	11.00

## ET imperial conduit

BS31

Size	Major dia.	TPI
5/8"	15.88	18.00
3/4"	19.05	16.00
1"	25.40	16.00
1 1/4"	31.75	16.00
1 1/2"	38.10	14.00
2"	50.80	14.00
2 1/2"	63.50	14.00
3"	76.20	14.00

## Thread dimension substitution chart

Metric	NPT (or NPS)	PG	BSP ISO Pipe	ET
M16	–	7, 9	–	5/8"
M20	1/2"	11, 13.5	1/2"	3/4"
M25	3/4"	16	3/4"	1"
M32	1"	21	1"	1 1/4"
M40	1 1/4"	29	1 1/4"	1 1/2"
M50	1 1/2"	36	1 1/2"	2"
M63	2"	42, 48	2"	2 1/2"
M75	2 1/2"	–	2 1/2"	3"
M90 x 2.0	3"	–	3"	–
M100 x 2.0	3 1/2"	–	–	–
M110 x 2.0	–	–	–	–
M120 x 2.0	–	–	–	–



# SCATTERGOOD & JOHNSON LTD

ELECTRICAL ENGINEERING & FLUID CONTROL DISTRIBUTORS

Est.1899

At Scattergood & Johnson Ltd, we pride ourselves on being a technical distributor to specialist industries.

Working with a range of quality product suppliers across a number of specialist markets, we are not your average 'box shifter' - we are your technical and supply chain partner.

We fully support every product we sell - for free! Our internal team and external sales engineers can answer any product or application question, no matter the complexity.

Backing up this technical ability is a range of 50,000+ products available from stock for nationwide next day delivery (same day if required!), or you can collect what you need from any of our trade counters around the UK.

Select your specialist interest below to learn more about how we can help.



Online, In Branch and On the Road - Scattergood & Johnson Ltd, there when you need us.

# [www.scatts.co.uk](http://www.scatts.co.uk)