

# Xbase Tech-Note

---

## ARM Cortex-A7 528MHz, 2 Ethernet, Safety Outputs

- Companion of X5 Wireless Handheld
- Wi-Fi access point dedicated to X5 safety network
- Dedicated safety signals for X5 Emergency Stop, Enabling and Selector
- Compatible with JMobile runtime. Supports JMobile protocols and gateway functions. JM4web HTML5 interface for web HMI.
- OPC UA server and client
- Compatible with Corvina Cloud secure remote connectivity.
- Plug-in module for system expansion.
- Rugged all metal design.
- Wide operating temperature range.



## Highlights

Xbase Base Station is a rugged and compact controller designed as the companion device for wireless safety handheld HMI devices such as X5. The device includes safety hardware matching the one installed in handheld devices and provides hardware safety signals ready for connection to machine safety circuits.

Safety wireless communication is based on Wi-Fi with support of 2.4 GHz and 5 GHz bands for worldwide operation. The combination of xBase and handheld devices such as X5 wireless implements the unique no-touch pairing procedure invented by EXOR and makes them the ideal solution for field interface to demanding systems such as the AGV's.

The product can integrate JMobile HMI with HTML interface and powerful gateway functions and Corvina Cloud secure remote connection. Speaking across the vast library of JMobile protocols as well as OPC UA to higher enterprise level control, the eXware is a true Plug and Use product.

- Linux-based open platform
- System settings by web browser
- 2 Ethernet ports for network separation WAN/LAN
- Dual-band Wi-Fi for safety communication to handheld devices
- Ready for Corvina Cloud secure remote connectivity
- Supports JMobile protocols including OPC UA server and client

# Xbase - Technical Data



System Resources	
CPU	i.MX6UL ARM Cortex A7 - 528 MHz
Operating System	Linux 4.14
Flash	4 GB
RAM	512 MB
FRAM	32Kbytes
Real Time Clock, RTC Back-up	Yes, rechargeable Lithium battery (not user-replaceable)
Buzzer	Yes
Sensors	Temperature (internal)
Safety Outputs	Emergency Stop (2+2 relay contacts NO) Enabling Device (2+2 relay contacts NO) Selector (4 source outputs)
Digital I/O	1DI, 2DO Safety Auxiliary functions
Interface	
Wireless	IEEE Std 802.11a/b/g/n (Safety Link)
Ethernet Port	2 (port 0 - 10/100, port 1 - 10/100)
USB Port	1 (Host v. 2.0, max. 500 mA)
Serial Port	1 (RS232/422/485, sw programmable)
SD Card	Yes
Expansion	1 slot for plug-in modules
Ratings	
Power Supply	24 Vdc (10 to 32 Vdc)
Current Consumption	0.4 A max. at 24 Vdc
Input Protection	Electronic
Environment Conditions	
Operating Temp	+5 to +45°C
Storage Temp	-20 to +70°C
Operating / Storage Humidity	5-85% RH, non condensing
Protection Class	IP20
Dimensions and Weights	
Faceplate LxH	45x134 mm
Depth D+T	102 mm
Weight	Approx 0.65 Kg
Installation	DIN Rail (TS35)
Approvals	
Certifications*	CE (Radio Equipment Directive 2014/53/UE for installation in industrial environments) FCC
Safety*	IEC 61508, EN ISO 13849-1, EN 61010-1 / EN 61010-2-201, UL61010-1 / UL61010-2-201
Safety functions*	SIL (IEC 61508): Emergency Stop SIL3, Enabling Device SIL 3, Selector SIL 1 Performance Level (EN ISO 13849-1): Emergency Stop PLd. Cat.3, Enabling Device PLd. Cat.3, Selector PLd. Cat.1

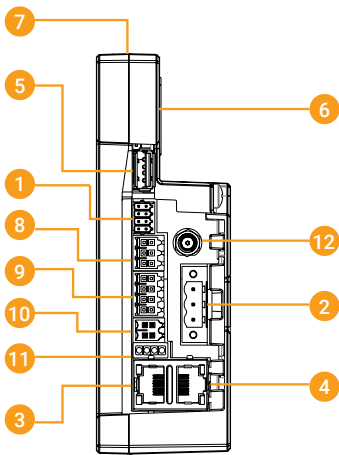

- 1 Serial Port
- 2 Power Supply
- 3 Ethernet Port #1
- 4 Ethernet Port #0
- 5 USB Host
- 6 Plug-in Expansion Slot

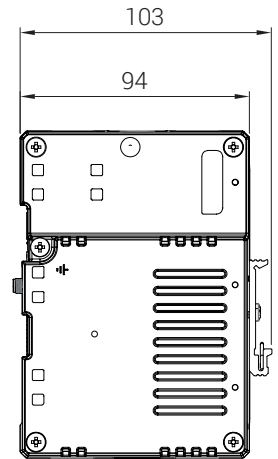
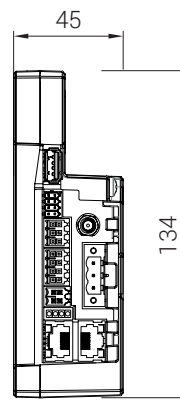
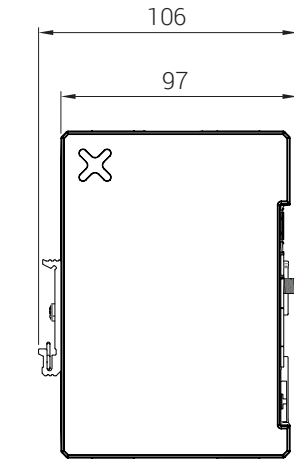

- 7 SD Card Slot
- 8 Selector Outputs
- 9 Safety Module Outputs
- 10 Auxiliary I/O
- 11 Status LEDs
- 12 Wi-Fi Antenna\*

\* connect the supplied antenna or a remote antenna via cable

\* In progress

## Ordering Information

Model	Part Number	Description
X5 Wireless	+X5SWJ0HYE0	HMI X5 WIRELESS JM
Xbase	+X5B0J000YE0	BASE STATION X5
Xcharging	+X5C00100YE0	CHARGING STATION



# SCATTERGOOD & JOHNSON LTD

ELECTRICAL ENGINEERING & FLUID CONTROL DISTRIBUTORS

Est.1899

At Scattergood & Johnson Ltd, we pride ourselves on being a technical distributor to specialist industries.

Working with a range of quality product suppliers across a number of specialist markets, we are not your average 'box shifter' - we are your technical and supply chain partner.

We fully support every product we sell - for free! Our internal team and external sales engineers can answer any product or application question, no matter the complexity.

Backing up this technical ability is a range of 50,000+ products available from stock for nationwide next day delivery (same day if required!), or you can collect what you need from any of our trade counters around the UK.

Select your specialist interest below to learn more about how we can help.



Online, In Branch and On the Road - Scattergood & Johnson Ltd, there when you need us.

# [www.scatts.co.uk](http://www.scatts.co.uk)