

INSTALLATION MANUAL

T121

Two-wire universal, isolated transmitter
for RTD sensors and thermocouples

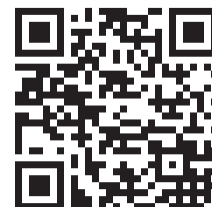

 **SENECA**



SENECA s.r.l.

Via Austria, 26 – 35127 – PADOVA – ITALY

Tel. +39.049.8705355 - 8705359 - Fax +39.049.8706287

Manuals and configuration software are available at website: www.seneca.it/products/t121

This document is property of SENECA Srl. Duplication and reproduction are forbidden, if not authorized. Contents of the present documentation refers to products and technologies described in it. This informations may be modified or integrated for technical and / or commercial requirements.

GENERAL DESCRIPTION

The T121 instrument converts input signals and retransmits them into a normalized current signal for 4 - 20 mA loop. The input signals may come from J, K, R, S, T, B, E, N, L thermocouples (EN 60584), RTD sensors (thermistors) as Pt100/500/1000, Ni100/120/1000, Cu50/100 and moreover, the instrument T121 can read voltage and resistance values.

MODULE LAYOUT

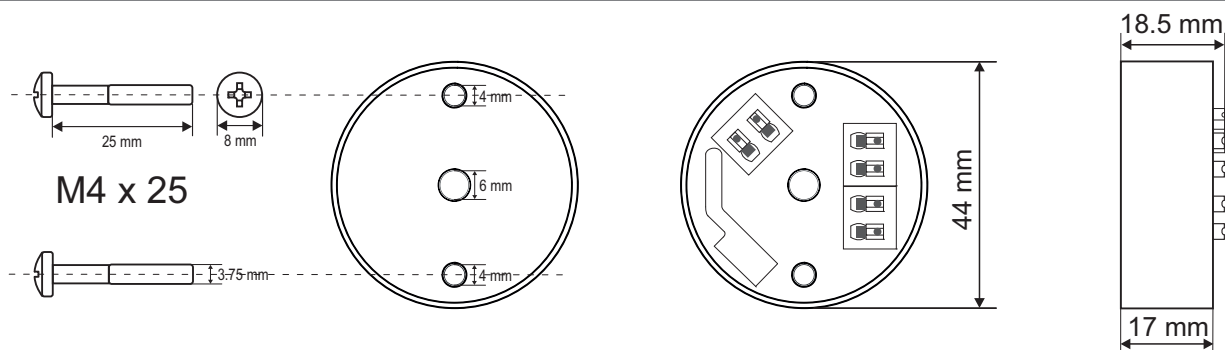

Weight	35 g.	Case	Material PA6 reinforced with glass-fibre, black color.
---------------	-------	-------------	--

GENERAL CHARACTERISTICS

- High accuracy.
- 16 bit conversion measurement.
- Insulation 1500 V~.
- Compact size and fast connections with spring terminals.
- All parameters can be configured with dedicated software: EASY SETUP downloadable from the website www.seneca.it in the T121 software section.

TECHNICAL SPECIFICATIONS

OUTPUT / POWER SUPPLY

<i>Operating range</i>	7 – 30 V $\overline{=}$
<i>Current output</i>	Loop 4 – 20 mA $\overline{=}$
<i>Load resistance</i>	1 k Ω @ 26 V $\overline{=}$, 21 mA (see: Load Resistance / Minimum operating voltage Diagram)
<i>Resolution</i>	2 μ A (> 13 bit)
<i>Output in case of over-range</i>	102.5% of full-scale (see Over-range table)
<i>Output in case of fault</i>	Programmable between 3.4 and 23 mA (see Fault table)
<i>Current output protection</i>	< 30mA

POTENTIOMETER INPUT

<i>Potentiometer value</i>	Potentiometer resistance: up to 1700 Ω without external resistor.
<i>Energizing current</i>	375 μ A
<i>Input impedance</i>	10 M Ω
<i>Sensor fault detection</i>	Yes, may be disabled

THERMOCOUPLE INPUT

<i>Input impedance</i>	10 M Ω
<i>Cold junction compensation</i>	- 40 – 100 \pm 1.5 $^{\circ}$ C, may be disabled
<i>Sensor fault detection</i>	Yes, may be disabled

TECHNICAL SPECIFICATIONS

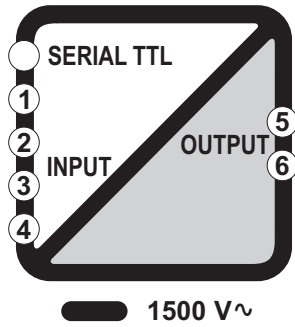
mV INPUT <i>Input impedance</i>	10 MΩ
RTD / RESISTOR INPUT <i>Energizing current</i> <i>Sensor fault detection</i> <i>Maximum cable resistance</i> <i>Influence of cable resistance</i>	375 μA Yes, may be disabled 25 Ω 0.0033 Ω/Ω
OTHER FEATURES <i>Sampling time</i> <i>Response time (10 – 90%)</i> <i>Network freq. rejection</i> <i>Error caused by EMI</i>	300 ms < 620 ms > 60 dB at 50 and 60 Hz < 0.5% (EMI = <i>ElectroMagnetic Interference</i>)
STANDARDS	EN61000-6-4 Electromagnetic emission, industrial environment EN61000-6-2 Electromagnetic immunity, industrial environment EN61010-1 Safety
INSULATION	
ENVIRONMENTAL COND. <i>Temperature</i> <i>Humidity</i> <i>Altitude</i> <i>Storage temperature</i> <i>Protection degree</i>	-40° – + 85°C. 30% – 90% not condensing. Up to 2000 m. a.s.l. -40° – + 105°C. IP20.
CONNECTIONS	6 spring terminals for 0.2 to 2.5 mm ² conductor section, suggested wire stripping 8 mm, 1 Serial programming connector TTL with 4 pin.

LOAD RESISTANCE / MINIMUM OPERATING VOLTAGE DIAGRAM

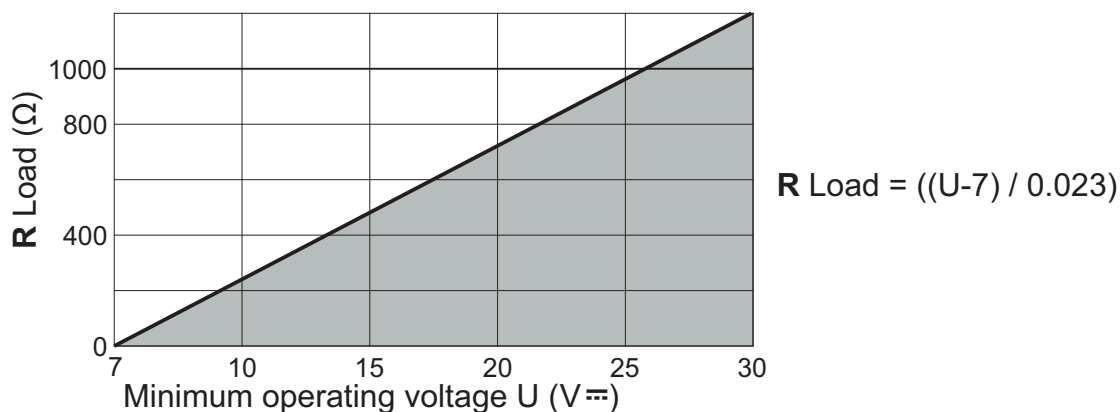

Input measurement range table

Type	Input	Measur. Range	Min. Span	Resolution	Standard
Thermocouple	J	-210° – 1200 °C	50 °C	5 µV	EN 60584
	K	-200° – 1372 °C	50 °C	5 µV	EN 60584
	R	-50° – 1768 °C	100 °C	5 µV	EN 60584
	S	-50° – 1768 °C	100 °C	5 µV	EN 60584
	T	-200° – 400 °C	50 °C	5 µV	EN 60584
	B(*)	0° – 1820 °C	100 °C	5 µV	EN 60584
	E	-200° – 1000 °C	50 °C	5 µV	EN 60584
	N	-200° – 1300 °C	50 °C	5 µV	EN 60584
	L	-200° – 800 °C	50 °C	5 µV	GOST 8.585
RTD	Ni100	-60° – 250 °C	20 °C	6 mΩ	DIN 43760
	Ni120	-80° – 260 °C	20 °C	6 mΩ	DIN 43760
	Ni1000	-60° – 120 °C	20 °C	6 mΩ	DIN 43760
	Pt100	-200° – 650 °C	20 °C	28 mΩ	EN 60751
	Pt500	-200° – 650 °C	20 °C	28 mΩ	
	Pt1000	-200° – 200 °C	20 °C	28 mΩ	
	Cu50	-180° – 200 °C	20 °C	6 mΩ	GOST 6651
	Cu100	-180° – 200 °C	20 °C	6 mΩ	GOST 6651
Voltage	mV	-150 – 150 mV	2.5 mV	5 µV	
Potentiometer	Ω	500 Ω – 100 kΩ	10 %	0.0015 %	
Resistor	Ω	0 – 400 Ω	10 mΩ	6 mΩ	
Resistor	Ω	0 – 1760 Ω	50 mΩ	28 mΩ	

NB .: EMI: Electromagnetic Interference can cause an error of <0.5% of span

Accuracy measurement table: the greater between the value of the sum A + B and the value C

Input type	A: % of measurement	B: % of Span	C: Minimum
Thermocouple J, K, T, N, E, L	0.05 %	0.05 %	0.5 °C
Thermocouple B(*), R, S	0.05 %	0.05 %	1 °C
RTD (**)	0.05 %	0.05 %	0.1 °C
Resistor	0.05 %	0.05 %	40 mΩ
Resistor	0.05 %	0.05 %	200 mΩ
Voltage	0.05 %	0.05 %	15 µV
Potentiometer	0.05 %	0.05 %	0.01 %

(*) TCB: ThermoCouple B: between 0° and 250 °C the measurement is null. (**) RTD: Errors calculated on the resistive value of sensor.

PRELIMINARY WARNINGS



Before performing any operation it is mandatory to read the full contents of this manual.

The module may only be used by qualified and skilled technicians in the field of electric installation. Specific documentation is available for download at website: www.seneca.it/products/t121.



Only the Manufacturer is authorized to repair the module or to replace damaged parts. The product is susceptible to electrostatic discharge, take appropriate countermeasures during any operation.



The warranty is null and void in case of improper use or tampering of the module or devices supplied by the Manufacturer, necessary for its correct operation, if the instructions in this manual have not been complied with.

PRELIMINARY WARNING



Disposal of electrical & electronic equipment (applicable throughout the EU and other countries with separate collection programs). The symbol found on this product or on its packaging, indicates that this product it must be handed over to an authorised collection point for **the recycling of electrical and electronic equipments**.

ELECTRICAL CONNECTIONS



In order to satisfy the electromagnetic compliance requirements: - **Use shielded cables for signals**.
 - Connect the shield to a preferential ground for devices.
 - Separate the shielded cables from other cables used for power installations. (transformers, inverters, motors, induction ovens, etc...).

• ANALOGIC INPUT

The module allows to read temperature inputs as TC thermocouples, RTD thermistors with 2, 3 or 4 wire connection and retransmits the input reading value on the 4 - 20 mA output loop. In addition T121 can be used to read voltages (mV) and resistors (Ω).

Thermocouple Connection	2 wire RTD Connection	3 wire RTD Connection	4 wire RTD Connection	Resistor Connection	Potentiometer Connection	Voltage (mV) Connection

2 wire connection

This connection can be used for short distances (< 10 m) between module and probe, you should remember that this connection introduces an error in the measurement (which can be removed by software programming) equivalent to the resistance contributed by the connection cables to the measurement. The module must be programmed by PC for 2-wire connection.

3 wire connection

This connection can be used for medium-long distances (> 10 m) between module and probe. The instrument performs compensation for the resistance of the connection cables. For the compensation to be correct, the resistor values of each conductor must be the same. The module must be programmed by PC for 3 wires connection.

4 wire connection

This connection can be used for medium-long distances (> 10 m) between module and probe. It offers maximum precision because the instrument measures the resistor of the sensor independently from the resistor of the cables. The module must be programmed by PC for 4 wires connection.

Potentiometer connection

A potentiometer with resistor between 500 and 1,7 k Ω may be connected directly to the module. If the potentiometer has a resistor greater than 1,7 k Ω **up to 100 k Ω maximum**, it will be necessary to use a resistor in parallel with potentiometer: **R = 1.5 k Ω** .

• ANALOG OUTPUT

Current loop connection 4 – 20 mA (regulated current).

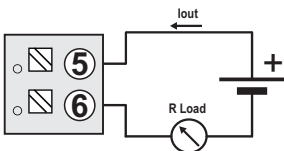

Note: in order to reduce the instrument's dissipation, we recommend to connect a Load $> 250 \Omega$ is connected

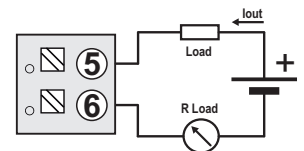

ELECTRICAL CONNECTIONS

• INSERTING AND REMOVING FROM THE TERMINALS WITH PUSH-WIRE CONNECTION

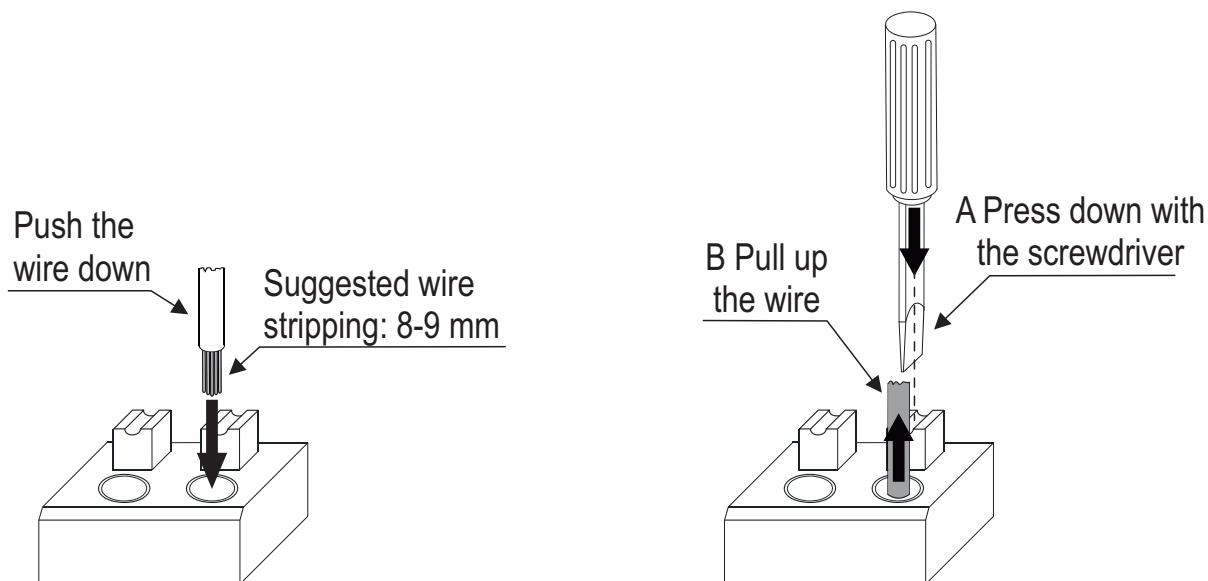

CONFIGURATIONS

• SOFTWARE CONFIGURATION

The PC configuration of this module is possible with the following accessories:

S117P1: RS232/USB, TTL/USB, RS485/USB asynchronous and **optoisolated** serial converter

EASY-USB: USB - UART TTL **non insulated** converter

The module can be powered from the programming connector.

Then you can configure the T121 even if disconnected from the 4 - 20 mA loop.

You can set the following parameters:

- Start and full measurement scale.
- RTD connection: 2 wires, 3 wires and 4 wires.
- Measurement filter: disabled or enabled.
- Output: Normal (4 – 20 mA) or reversed (20 – 4 mA).
- Input type.
- Cable resistance compensation for 2 wires measurement.
- Output value in case of failure: Value in mA.
- Cold junction compensation : YES (enabled) / NO (disabled)
- Over-Range: NO (Limited output between 0 % and 100%) or YES (limited output from -2.5 % to 102.5 %).

The following table shows the values of the parameters.

• OUTPUT LIMITS / OVER-RANGE / FAULT TABLE

Output limits	Over-range / $\pm 2.5 \%$	Fault $\pm 5 \%$
20 mA	20.4 mA	21 mA
4 mA	3.6 mA	< 3.4mA

• PROGRAMMING CONNECTOR ACCESS

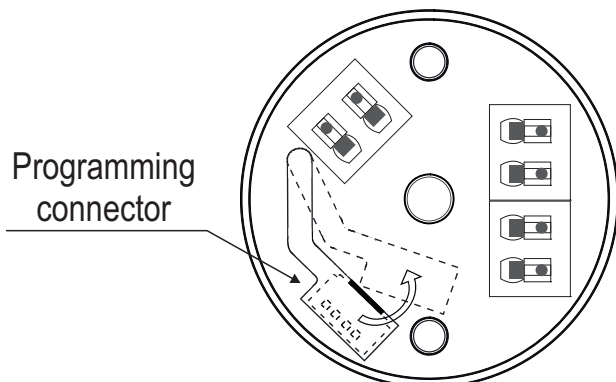

- 1 Pull up the plastic protective cover by using the specific slot.
- 2 Move the plastic cover as shown in the picture aside.

• CONNECTIONS TO THE PROGRAMMING CONVERTER S117P1

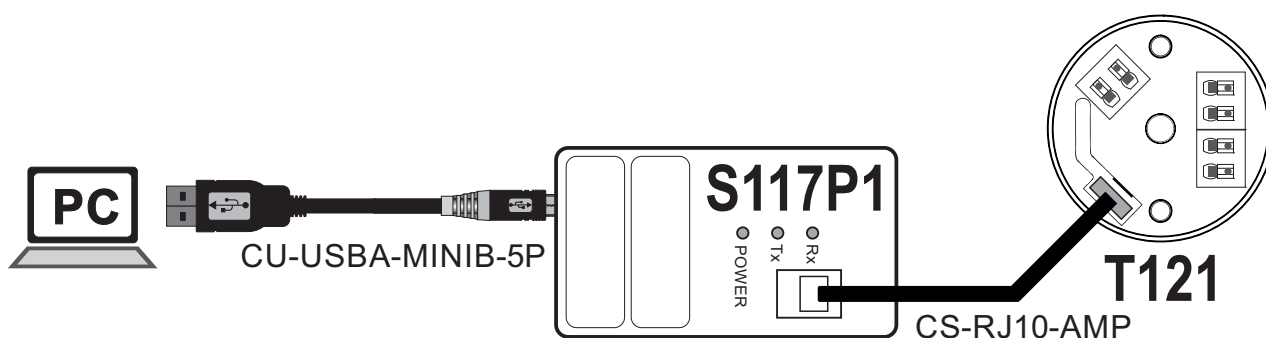

• CONNECTIONS TO THE PROGRAMMING CONVERTER EASY-USB

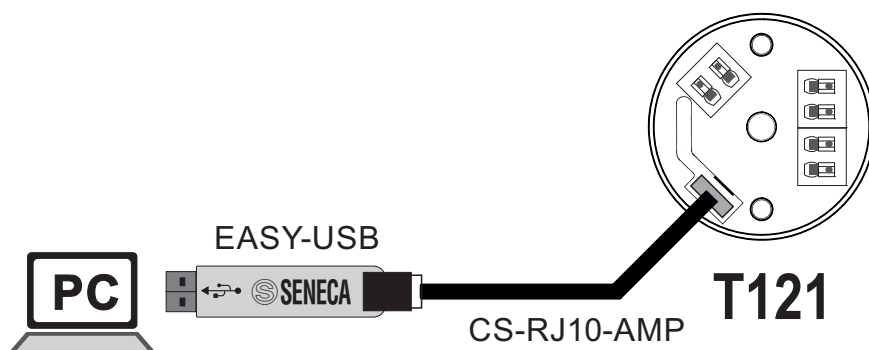

FACTORY SETTINGS

• DEFAULT CONDITION FOR THE CONFIGURATION PARAMETERS

The instrument leaves the factory with the following default configuration (unless otherwise indicated on the instrument case):

<i>TC wiring</i>	To terminals 3+ and 4-
<i>Cold junction compensation</i>	YES (enabled)
<i>Filter</i>	NO (disabled)
<i>Reverse output</i>	NO (disabled)
<i>TC type</i>	K
<i>Measurement range start</i>	0 °C
<i>Measurement full Scale</i>	1000 °C
<i>Output signal in case of fault</i>	21 mA
<i>Over-Range</i>	YES (limited output between -2.5 % and 102.5 %).

TABLE OF USER CONFIGURABLE SENSOR TYPES

Sensor	Type	Operating range
Custom	mV	± 150 mV
	RTD < 400 Ω	0 – 400 Ω
	RTD < 1760 Ω	0 – 1760 Ω
	TC	± 150 mV
	Potentiometer	500 Ω – 100 k Ω
	Resistor < 400 Ω	0 – 400 Ω
	Resistor < 1760 Ω	0 – 1760 Ω

CUSTOMIZATION OF THE INTERPOLATION CURVE

The EASY SETUP software allows the configuration of the T121 module in order to linearise also the sensors Custom if their operating range is within the indicated limits. The curves of some additional sensors are already included in the software.

There is also a tool to properly configure the S311A product for T121 module connection.

CONTACTS

Technical support	support@seneca.it
Product Informations	sales@seneca.it



SCATTERGOOD & JOHNSON LTD

ELECTRICAL ENGINEERING & FLUID CONTROL DISTRIBUTORS

Est.1899

At Scattergood & Johnson Ltd, we pride ourselves on being a technical distributor to specialist industries.

Working with a range of quality product suppliers across a number of specialist markets, we are not your average 'box shifter' - we are your technical and supply chain partner.

We fully support every product we sell - for free! Our internal team and external sales engineers can answer any product or application question, no matter the complexity.

Backing up this technical ability is a range of 50,000+ products available from stock for nationwide next day delivery (same day if required!), or you can collect what you need from any of our trade counters around the UK.

Select your specialist interest below to learn more about how we can help.



Online, In Branch and On the Road - Scattergood & Johnson Ltd, there when you need us.

www.scatts.co.uk