



# INSTALLATION AND USER'S MANUAL

Language of the manual	English
Product	<b>Z-SUPPLY</b>
Description	<b>Single-phase switching power supply: 24V @ 1.5A</b>

<b>Contents:</b>	<b>Page</b>
1.0 Disclaimer	2
2.0 Description and General features	2
2.1 Description	
2.2 General features	
3.0 Technical specifications	2
3.1 General specifications	
3.2 Power supply / input	
3.3 Output voltage	
3.4 Output relay, «power good»	
3.5 Enclosure	
3.6 Connectors	
3.7 Environmental conditions	
3.8 Standards	
3.9 Module layout	
4.0 Preliminary instructions for use	4
5.0 Installation	5
5.1 Installation on/ removal from DIN 46277 rail	
6.0 Electrical connections	6
6.1 Power supply	
6.2 24 Vdc-output by screw terminal	
6.3 24 Vdc-output by IDC10 for Seneca modules	
6.4 Output relay and «power-good»	
7.0 LEDs for signalling	7
8.0 Accessories	8



Manufacturer	  UNI EN ISO 9001    CERTIFICATE Nr. 9115.SENE	<b>Seneca s.r.l.</b> Via Austria, 26 35127 - PADOVA - ITALIA Tel. +39.049.8705355 - 8705359 - Fax +39.049.8706287
Web		<a href="http://www.seneca.it">www.seneca.it</a>
Mail		Technical support: <a href="mailto:support@seneca.it">support@seneca.it</a> Product information: <a href="mailto:sales@seneca.it">sales@seneca.it</a>

This document is property of SENECA srl. Duplication and reproduction are forbidden, if not authorized. Contents of the present documentation refers to products and technologies described in it. All technical data contained in the document may be modified without prior notice Content of this documentation is subject to periodical revision.

## 1.0 DISCLAIMER



Before executing any operation it's mandatory to read all the content of this user manual. Only electrical-skilled technicians can use the module described in this user Manual; it is responsibility of the installer to verify that the installation complies with safety standards.



Only the Manufacturer is authorized to repair the module or to replace damaged components.



No warranty is guaranteed in connection with faults resulting from improper use, from modifications or repairs carried out by Manufacturer-unauthorised personnel on the module, or if the content of this user Manual is not followed.



This module is designed for connection to hazardous electric voltages. Ignoring this warning can result in severe personal injury or mechanical damage.

## 2.0 DESCRIPTION AND GENERAL FEATURES

### 2.1 Description

Single-phase switching power supply for Seneca modules: it can be installed on DIN 46277 rail. Input voltage range: 100-260 Vac @ 47 - 63 Hz; output: 24 Vdc @ 1,5 A.

### 2.2 General features

- AC input rated voltage from 110 Vac to 230 Vac @ 47 Hz-63 Hz, 0.7 A
- DC input rated voltage from 110 Vdc to 315 Vdc @ 0.7 A
- Output voltage: 24 Vdc  $\pm$  2% (it is possible the redundancy between two Z-SUPPLY through connection in parallel of their respective output, ONLY by IDC10 connector)
- Output maximum-current: 1.5 A
- Internal fuse: 1.25 A, type T (delayed), for the protection against of the over-current and over-voltage
- Quick installation on DIN 46277 rail
- Isolation up to 3 KVac between input voltage and output voltage
- LED to signal the status of the output voltage and power supply
- It is possible to supply the modules of the Seneca Z-PC Line through IDC10 connector

## 3.0 TECHNICAL SPECIFICATIONS

### 3.1 General specifications

Efficiency	87% @ 1.5 A, 230 V, $\cos\Phi$ 0,7
Power supplied	36 W max
Isolation between: input, output	3 KVac / 60 s
Over-voltage category/Pollution degree	II/2
Power consumption (no load)	< 1.4 W
Power consumption (full load)	< 6.6 W
Current trip protection	1.7 A

Max resistive load	15 $\Omega$
Max capacitive load	3000 $\mu$ F
Output ripple	< 40 mV
Output regulation	< 1%
Dynamic regulation	< 1%
Turn-off time	15 ms @ 120 Vac, 60 ms @ 230 Vac

### 3.2 Power supply/ input

Rated voltage	110- 240 V @ 50..60 Hz
Input range for AC power supply	100- 265 V @ 47-63 Hz; 110-315 Vdc
Current consumption	Max 0.7A @ 100V; 0.27 A @ 265 V
External input fuse (recommended)	2 A, type T
Internal input fuse	1.25 A, type T (delayed), it can not be replaced
Inrush current limitation (plug in)	<25 A
Power factor	>0.60
Start-up voltage with full load	~100 Vac (with load: 15 $\Omega$ )
Shut-down voltage	~90Vac

### 3.3 Output voltage

Output voltage	24 Vdc $\pm$ 2 %
Output redundancy (more Z-SUPPLY modules)	The output of a Z-SUPPLY can be parallel-connected with the output of another Z-SUPPLY( <b>only</b> by IDC10);see fig.6
Max output current	1.5 A
Over-load limit current	1.7 A
Load regulation	< 1%
Rated ripple	< 50 mVpp
Protection against the short-circuit and over-load	Yes, hiccup @ over-load limit with auto reset

Derating curve for output, the derate starts at 55 °C for 0.02 A/K

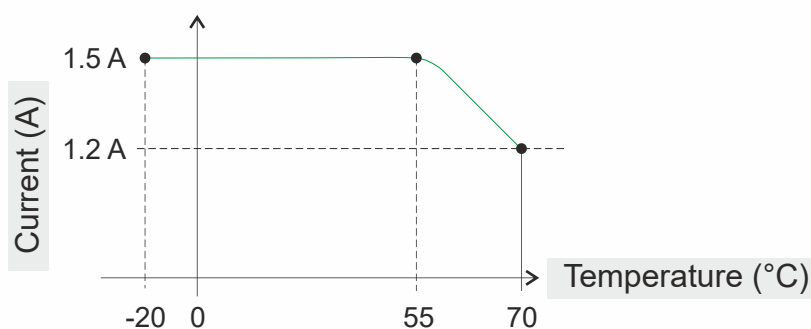

### 3.4 Output relay, «power-good»

Relay type	N.O. with 1 A / 30 Vdc (resistive)
Relay activation	Output voltage > 23.5 Vdc

### 3.5 Enclosure

Dimension	100 x 35 x 111 mm
Box; protection class	Black plastic, IP20 (International protection)
Weight	215 g

### 3.6 Connectors

Connectors	IDC with 10 pins for Seneca bus (output redundancy)
	Removable screw terminals: pitch 5.08 mm

### 3.7 Environmental conditions

Operating temperature	-20 °C.. +70 °C
Humidity	30 - 90% a 40 °C not condensing
Storage temperature	-40 .. +85°C

### 3.8 Standards

Standards	EN 61000-6-4/ 2007 (electromagnetic emission, in industrial environment)
	EN 61000-6-2/ 2005 (electromagnetic immunity, in industrial environment)
	EN 61010-1/ 2001 (safety)

### 3.9 Module layout

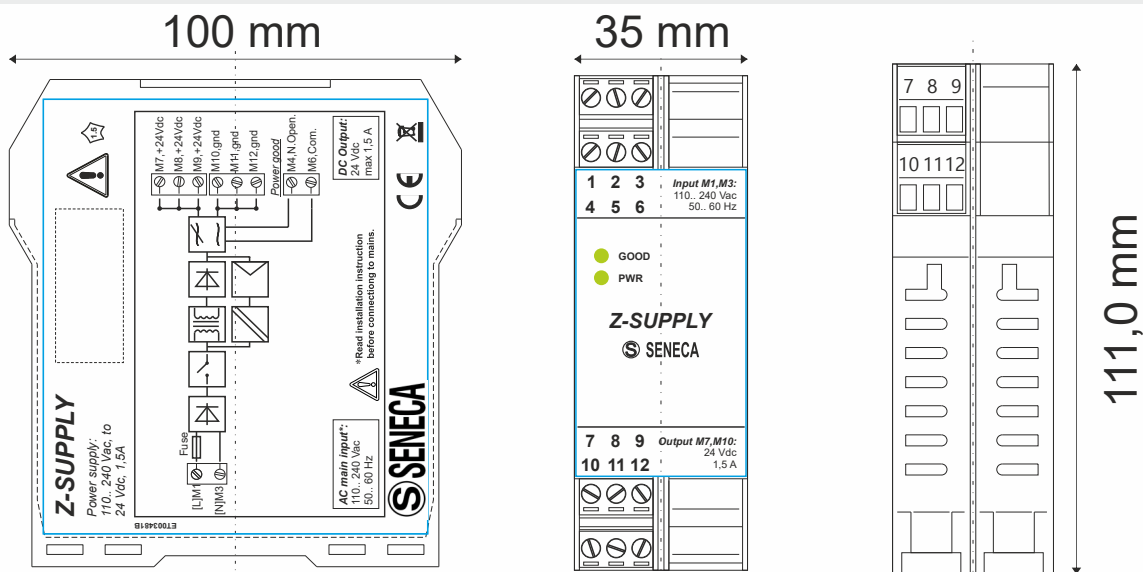

## 4.0 PRELIMINARY INSTRUCTIONS FOR USE

The module is designed to be installed on DIN 46277 rail (fig. 1) in vertical position.



No operation on the module is allowed while it is power on.  
**It is forbidden** to install the module near heat-emitting devices.



It is recommended that the use and installation operations are performed by an electrical-skilled technician because it is possible to be exposed to risk of electrocution.  
 Z-SUPPLY module can achieve a very high temperature, so it is important to be careful when using it.

## 5.0 INSTALLATION



**Power off the module before cabling.**

To install/remove the Z-SUPPLY on/from DIN 46277 rail, execute the following operations (Fig.1a and Fig.1b)

### 5.1 Installation on/removal from DIN 46277 rail

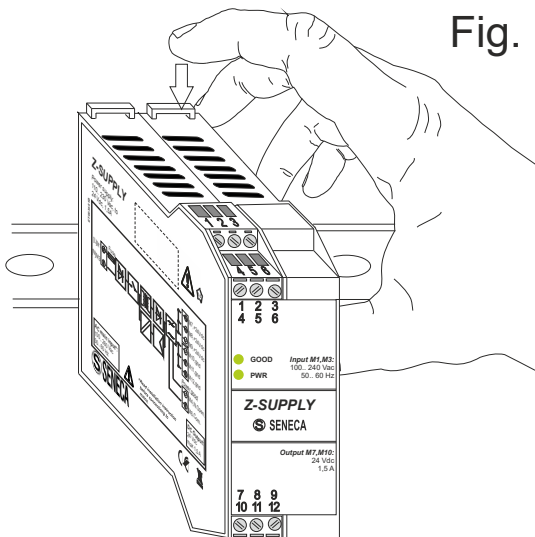

Fig. 1a

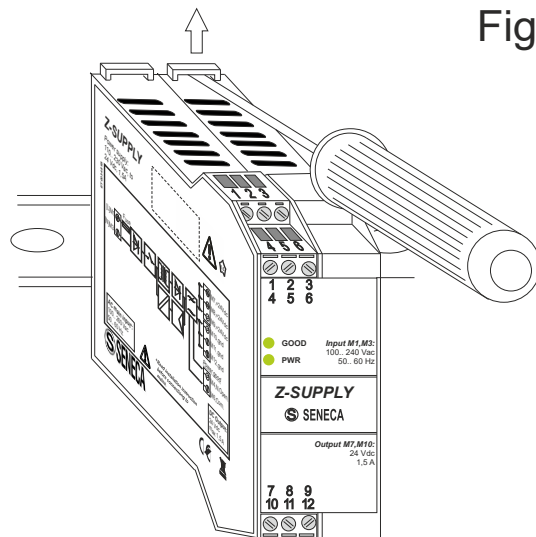

Fig. 1b

#### INSTALLATION

- 1) Pull the four latches (placed in the back-side panel) outwards;
- 2) insert the module in a DIN rail free slot;
- 3) make sure that the IDC10-connector pins are inserted on the slot correctly;
- 4) press the four latches inwards.

#### REMOVAL

- 1) Pull the four latches (placed in the back-side panel) outwards, using a screwdriver;
- 2) pull out the module gently.

It's important to insert the pins on the slot correctly because IDC10-connector is polarized; this connection is facilitated by use of a female/male insertion between IDC10 connector and DIN rail slot (Fig 1c and Fig 1d).

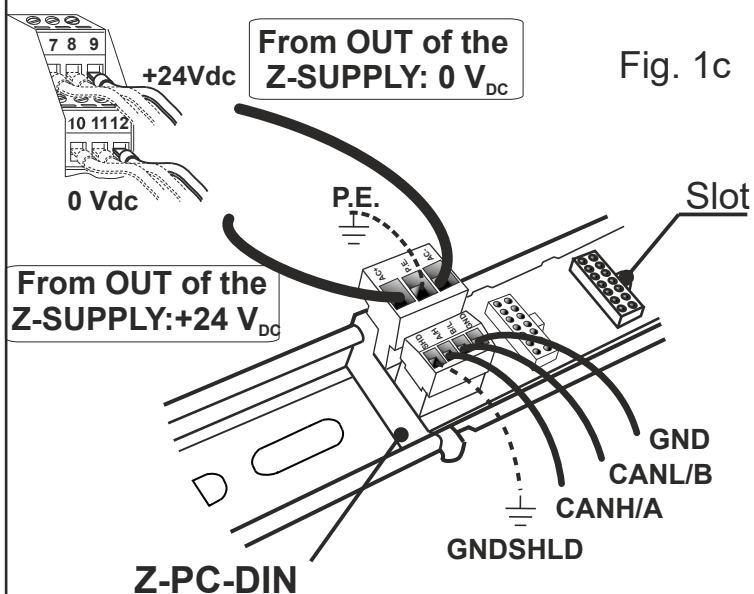

Fig. 1c

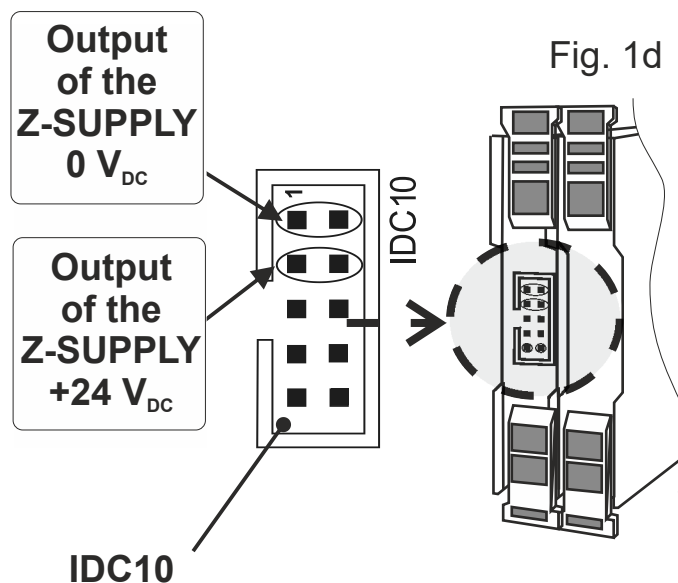

Fig. 1d

For better performance and long term functioning, **it is forbidden** to obstruct the Z-SUPPLY ventilation openings (Fig. 2).

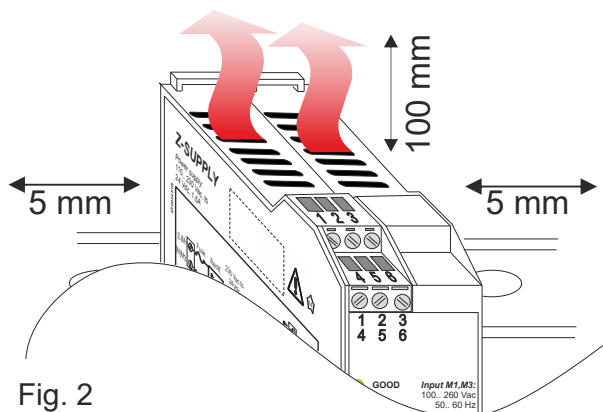

Fig. 2

## 6.0 ELECTRICAL CONNECTIONS

### 6.1 Power supply

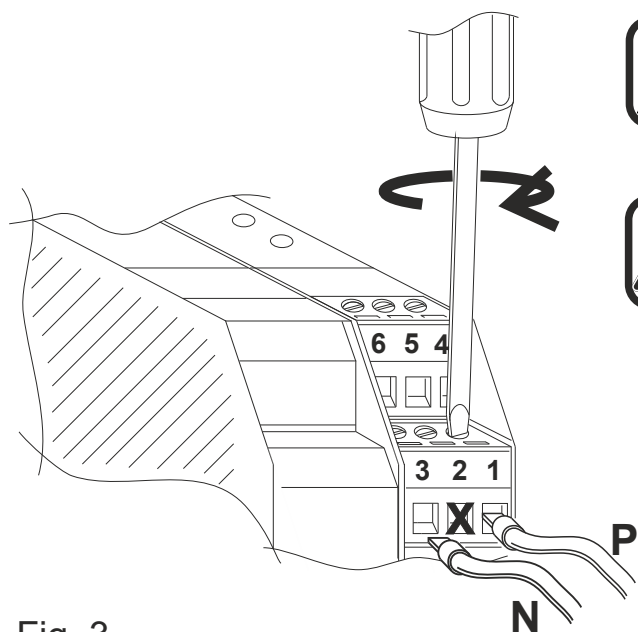

Fig. 3



The electrical connections should only be carried out on a disconnected module and under ESD safe conditions.



**Make sure that the Z-SUPPLY is power off before executing any operations.**

Before powering the Z-SUPPLY, it is necessary to cable phase (P) and neutral (N) of the single-phase network, through the screw terminals 3 and 1.



Wire section (recommended):  
0.5 mm<sup>2</sup>-2.5 mm<sup>2</sup>

### 6.2 24 Vdc-output by screw terminals

The output is available on the screw terminals M7,M8,M9 (+24 Vdc) and M10,M11,M12 (0 V dc) as shown in Fig.4.

The output is protected against the current over-load. If the output is over-loaded, Z-SUPPLY protection system will be activated automatically and output value is not stable (hiccup). Protection status can be shown through «good» LED (blinking light); in this case, it is necessary to decrease the output load. When the Z-SUPPLY is restarted, will be reset automatically.

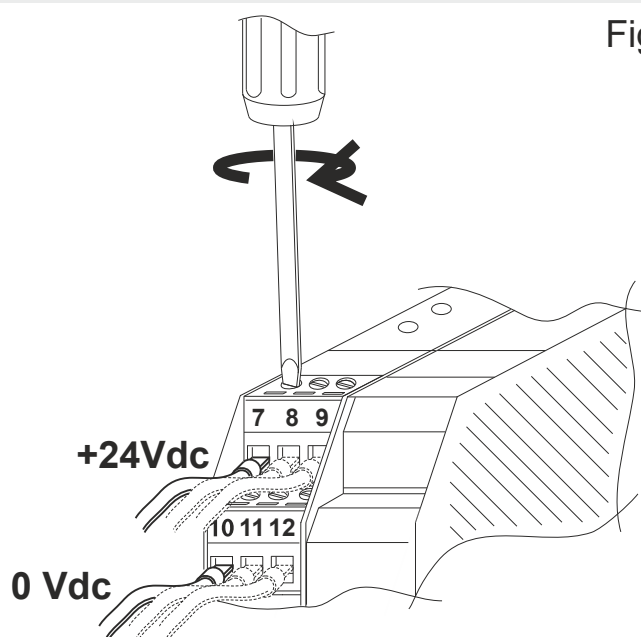

Fig. 4

### 6.3 24 Vdc-output by IDC10 for Seneca modules

Before using 24 Vdc output through IDC10 connector, see Fig.1d and in Fig.1c. Through IDC10 connector, Z-SUPPLY can power up to 15 modules.

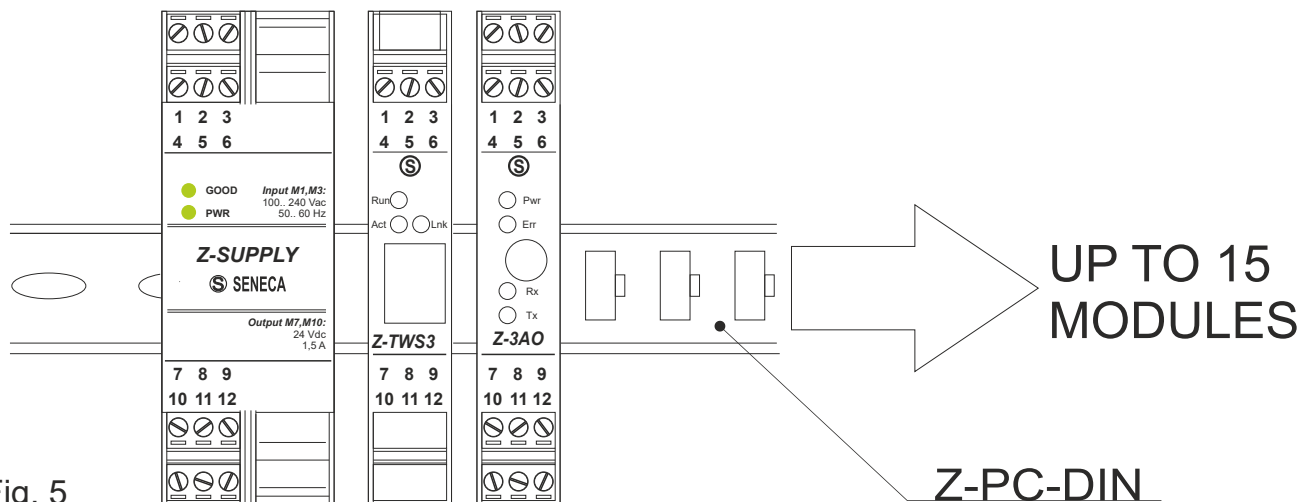

Fig. 5

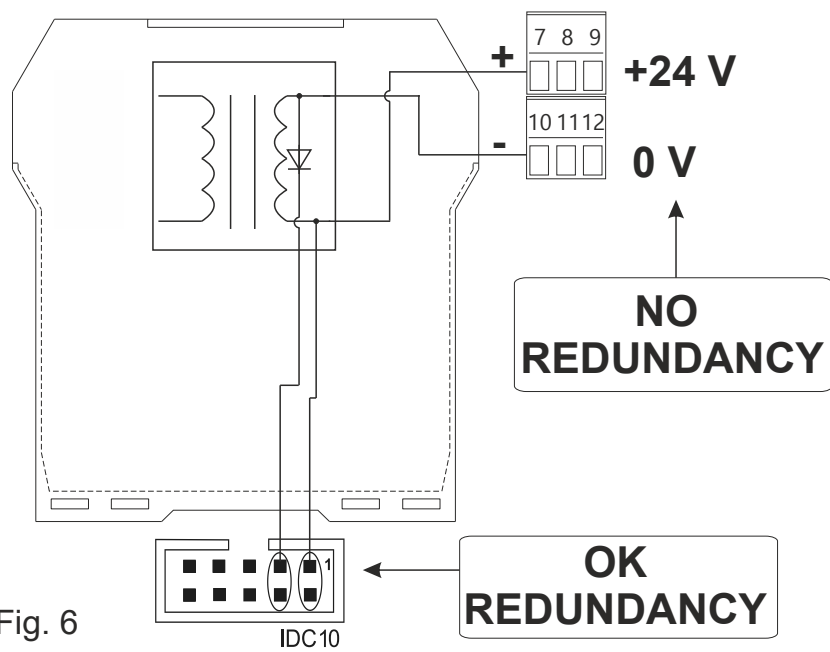

Fig. 6

All the connection shown in fig.6 are internal, into the Z-SUPPLY.

As you can see in the fig.6, there is a diode internally connected at the end of the IDC10 output: so, it is possible to connect more Z-SUPPLY modules in parallel **ONLY** if the redundant outputs are connected by IDC10.

**IT IS FORBIDDEN** to connect more Z-SUPPLY modules in parallel using the redundant outputs by screw terminals (in alternative, connect a diode at the end of the output, for each Z-SUPPLY, externally).

### 6.4 Output relay and «power good»

The output voltage equal to 24 Vdc is guaranteed by an internal relay, which enables the output voltage only if the voltage between its terminals is greater than 23.5 V. If the output voltage is supplied correctly, the LED «good» will be on; otherwise, if a over-loading occurs, the LED «good» will be blinking. The relay contacts are available on the screw terminals M4 (normally open) and M6 (common).

### 7.0 LEDs for SIGNALLING

LED	STATUS	MEANING
Good	Constant light	24 Vdc output is ON and regulated
	Off	24 Vdc output is disabled
	Blinking light	Output over-load
Pwr	Constant light	24 Vdc output is ON
	Off	24 Vdc output is OFF

**8.0 ACCESSORIES**

CODE		DESCRIPTION
Z-PC-DIN	AL1-35	DIN rail support with screw terminals P=35 mm
	AL2-17,5	DIN rail support with screw terminals P=17,5 mm
Z-PC-DIN	1-35	DIN 1 slot support for rear connector P=35 mm
	2-17,5	DIN 2 slot support for rear connector P=17,5 mm
	4-35	DIN 4 slot support for rear connector P=35 mm
	8-17,5	DIN 8 slot support for rear connector P=17,5 mm



Disposal of Electrical & Electronic Equipment (Applicable throughout the European Union and other European countries with separate collections programs; see WEEE directive). This symbol, found on your product or on its packaging, indicates that this product should not be treated as household waste when you wish to dispose of it. Instead, it should be handed over to an applicable collection point for the recycling of electrical & electronic equipment. By ensuring this product is disposed of correctly, you will help prevent potential negative consequences to the environment and human health, which could otherwise be caused by inappropriate disposal of this product. The recycling of materials will help to conserve natural resources. For more detailed information about the recycling of the product, please contact your local city office, waste disposal service of the retail store where you purchased this product.



# SCATTERGOOD & JOHNSON LTD

ELECTRICAL ENGINEERING & FLUID CONTROL DISTRIBUTORS

Est.1899

At Scattergood & Johnson Ltd, we pride ourselves on being a technical distributor to specialist industries.

Working with a range of quality product suppliers across a number of specialist markets, we are not your average 'box shifter' - we are your technical and supply chain partner.

We fully support every product we sell - for free! Our internal team and external sales engineers can answer any product or application question, no matter the complexity.

Backing up this technical ability is a range of 50,000+ products available from stock for nationwide next day delivery (same day if required!), or you can collect what you need from any of our trade counters around the UK.

Select your specialist interest below to learn more about how we can help.



Online, In Branch and On the Road - Scattergood & Johnson Ltd, there when you need us.

# [www.scatts.co.uk](http://www.scatts.co.uk)