





INSTALLATION MANUAL

Z-KEY Z-KEY-P

PRELIMINARY WARNINGS

The word **WARNING** preceded by the symbol  indicates conditions or actions that put the user's safety at risk. The word **ATTENTION** preceded by the symbol  indicates conditions or actions that might damage the instrument or the connected equipment. The warranty shall become null and void in the event of improper use or tampering with the module or devices supplied by the manufacturer as necessary for its correct operation, and if the instructions contained in this manual are not followed.

	WARNING: The full content of this manual must be read before any operation. The module must only be used by qualified electricians. Specific documentation is available via QR-CODE shown on page 1.
	The module must be repaired and damaged parts replaced by the Manufacturer. The product is sensitive to electrostatic discharges. Take appropriate measures during any operation.
	Electrical and electronic waste disposal (applicable in the European Union and other countries with recycling). The symbol on the product or its packaging shows the product must be surrendered to a collection centre authorized to recycle electrical and electronic waste.



DOCUMENTATION
Z-KEY



DOCUMENTATION
Z-KEY-P



SENECA s.r.l.; Via Austria, 26 – 35127 – PADOVA – ITALY; Tel. +39.049.8705359 - Fax +39.049.8706287

CONTACT INFORMATION

Technical support	support@seneca.it	Product information	sales@seneca.it
-------------------	-------------------	---------------------	-----------------

This document is the property of SENECA srl. Copies and reproduction are prohibited unless authorised. The content of this document corresponds to the described products and technologies. Stated data may be modified or supplemented for technical and/or sales purposes.

MODULE LAYOUT

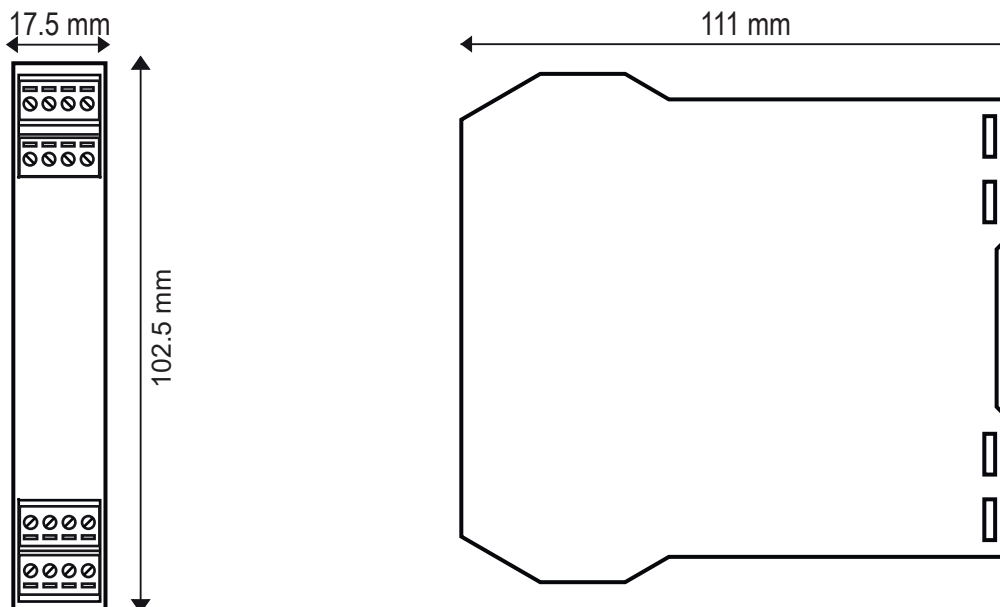

Dimensions: 17.5 x 102.5 x 111 mm, **Weight:** 100 g; **Enclosure:** PA6, black

SIGNALS VIA LED ON FRONT PANEL

LED	STATUS	LED meaning
PWR	ON	The device is powered correctly
SD / COM Z-KEY version only	Flashing	Accessing the microSD card
SD / COM Z-KEY-P version only	Flashing	Profinet communication active
	Off	No Profinet communication
TX1	Flashing	Data transmission on port #1 RS485
RX1	Flashing	Data receipt on port #1 RS485
TX2	Flashing	Data transmission on port #2 RS485/RS232
RX2	Flashing	Data reception on port #2 RS485/RS232
ETH ACT Green	Flashing	Packet transmission on Ethernet port
ETH LNK Yellow	ON	Ethernet connection present

TECHNICAL SPECIFICATIONS

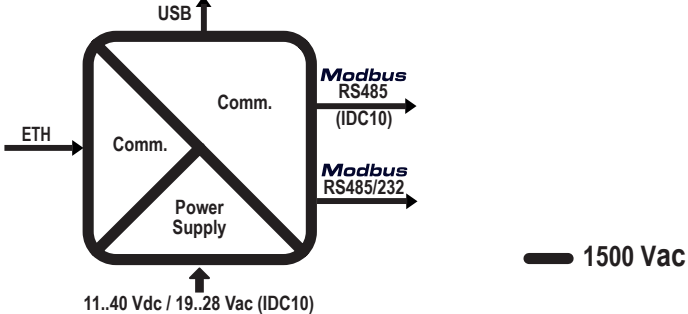
STANDARDS	<p>EN61000-6-4 Electromagnetic emissions, industrial environment. EN61000-6-2 Electromagnetic immunity, industrial environment. EN60950-1 Security in information processing equipment</p> <p>Additional notes: a 1 A delayed fuse must be installed near the module, in series with the power supply connection.</p>
INSULATION	
ENVIRONMENTAL CONDITIONS	<p><i>Temperature:</i> -25 °C – + 65 °C <i>Humidity:</i> 30%– 90% non condensing. <i>Altitude:</i> Up to 2000 m above sea level <i>Storage temperature:</i> -30 °C – + 85 °C <i>Protection rating:</i> IP20 (Not evaluated by UL)</p>
ASSEMBLY	IEC EN60715, 35mm DIN rail in vertical position.
CONNECTIONS	<p>3-way removable screw terminals, pitch 5 mm Rear connector IDC10 for DIN bar 46277 RJ45 front connector SMA antenna connector side micro USB port microSD card slot</p>
POWER SUPPLY	<p>Voltage: 11 – 40 Vdc; 19 – 28 Vac 50 – 60 Hz Absorption: Max. 1,5W</p>
COMMUNICATION PORTS	<p><u>RS242 or RS485 switchable on terminal 10 - 11 - 12</u> Maximum Baud rate 115 k, maximum cable length RS232 < 3m <u>RS485 IDC10 rear connector:</u> Maximum Baud rate 115 k. <u>RJ45 front Ethernet connector:</u> 100 Mbit/s, maximum distance 100 m</p>

ATTENTION

The device may only be powered by a power supply unit with a limited energy electric circuit max. 40Vdc / 28Vac Max output in accordance with CAN/CSA-C22.2 No. 61010-1-12 / UL Std. No. 61010-1 (3rd Edition) chapter 6.3.1/6.3.2 and 9.4 or class 2 according to CSA 223/UL 1310.

FACTORY IP ADDRESS

The default module IP address is static: **192.168.90.101**

WEB SERVER

To access the maintenance Web Server with **192.168.90.101** factory IP address:

Default user: **admin**, Default password: **admin**, **http://192.168.90.101**

IDC10 CONNECTOR

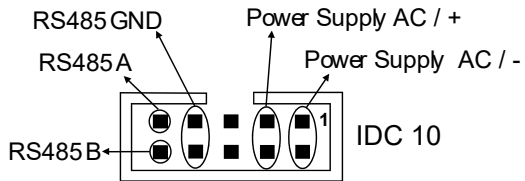

The illustration shows the meanings of the various IDC10 connector pins if signals are to be sent via them directly.

SETTING THE DIP-SWITCHES

SETTINGS OF FACTORY PARAMETERS

This procedure returns the IP to the factory one (192.168.90.101) and the Web Server/FTP server access credentials to user: admin and password: admin.

1. Turn the module off and set all eight SW1 DIP-switches to ON.
2. Turn on the module and wait 10 seconds.
3. Turn the module off and set all eight SW1 DIP-switches to OFF.

KEY		
1	ON	
0	OFF	

RS232/RS485 SETTING: RS232 or RS485 configuration on terminals 10-11-12 (serial port 2)

SW2			
1	ON		RS232 ACTIVATION
0	OFF		RS485 ACTIVATION

INSTALLATION REGULATIONS

The module has been designed for vertical installation on a DIN 46277 rail. For optimal operation and long life, adequate ventilation must be provided. Avoid positioning ducting or other objects that obstruct the ventilation slots. Avoid mounting modules over heat-generating equipment. Installation in the bottom part of the electrical panel is recommended.

ATTENTION

These are open-type devices and intended for installation in an end enclosure / panel offering mechanical protection and protection against spread of fire.

ELECTRICAL CONNECTIONS

CAUTION

On first start-up the module must be supplied without any interruptions for at least 72 hours to charge the internal batteries. Switch the module off with the PS1 button before connecting inputs and outputs.

To meet the electromagnetic immunity requirements:

- use shielded signal cables;
- connect the shield to a preferential instrumentation earth system;
- separate shielded cables from other cables used for power installations (transformers, inverters, motors, etc...).

POWER SUPPLY	SERIAL PORT 2: RS485 SW2 = OFF	SERIAL PORT 2: RS232 SW2 = ON
Tens. aus. 1 Vac/Vdc 2 Vac/Vdc 3	GND 10 A (+) 11 B (-) 12	GND 10 RX 11 TX 12

ATTENTION

Use only copper or copper-clad aluminium or AL-CU or CU-AL conductors



SCATTERGOOD & JOHNSON LTD

ELECTRICAL ENGINEERING & FLUID CONTROL DISTRIBUTORS

Est.1899

At Scattergood & Johnson Ltd, we pride ourselves on being a technical distributor to specialist industries.

Working with a range of quality product suppliers across a number of specialist markets, we are not your average 'box shifter' - we are your technical and supply chain partner.

We fully support every product we sell - for free! Our internal team and external sales engineers can answer any product or application question, no matter the complexity.

Backing up this technical ability is a range of 50,000+ products available from stock for nationwide next day delivery (same day if required!), or you can collect what you need from any of our trade counters around the UK.

Select your specialist interest below to learn more about how we can help.



Online, In Branch and On the Road - Scattergood & Johnson Ltd, there when you need us.

www.scatts.co.uk