

SMALL COMPACT THERMOSTAT

KTO 111 / KTS 111



- > Safe wiring with Push-In connection terminal
- > Faster and tool-free wiring
- > Improved air intakes for ventilation
- > Easy adjustability of switch temperature setting
- > for use in up to 5,000 m altitude

The mechanical thermostats KTO 111 and KTS 111 are two state regulators for use up to 5,000 meters in altitude, thanks to optimised air gap and increased creepage distance. By use of Push-In terminals the thermostat is wired tool-free. The Push-In terminals provide constant pressure on the wires to prevent them from coming loose (e.g. during transport).

KTO 111: Thermostat (NC); contact breaker for regulating heaters. The contact opens when temperature is rising.

KTS 111: Thermostat (NO); contact maker for regulating of filter fans and heat exchangers or for switching signal devices when temperature limit has been exceeded. The contact closes when temperature is rising.



TECHNICAL DATA

Switch temperature difference	7 K (±4 K tolerance)
Sensor element	thermostatic bimetal
Contact type	snap-action contact
Service life	100,000 cycles verified
Max. operating voltage, frequency range	AC 250 V, 50-60 Hz
Max. inrush current	AC 16 A for 10 sec.
Connection ¹	2 Push-In clamps rigid wire 2.5 mm ² (AWG 14) stranded wire 1.5 mm ² (AWG 16)
Mounting	clip for 35 mm DIN rail, EN 60715
Casing	plastic according to UL94 V-0, light grey
Dimensions	60 x 33 x 41 mm
Weight	approx. 40 g
Fitting position	variable
Operating/Storage temperature	-45 to +80 °C (-49 to +176 °F)
Operating/Storage humidity	max. 90 % RH (non-condensing)
Protection type/Protection class	IP20 / II
Overvoltage category/Altitude	II: up to 5,000 m; III: up to 2,000 m

¹ Stripped length of rigid wire: 10 to 12 mm. When connecting with wires, wire end ferrules must be used (square or trapezoid crimp). Length of wire end ferrule: 10 mm or 12 mm.

Important note: The contact system of the regulator is subjected to environmental influences, thus the contact resistance may change. This can lead to a voltage drop and/or self-heating of the contacts.

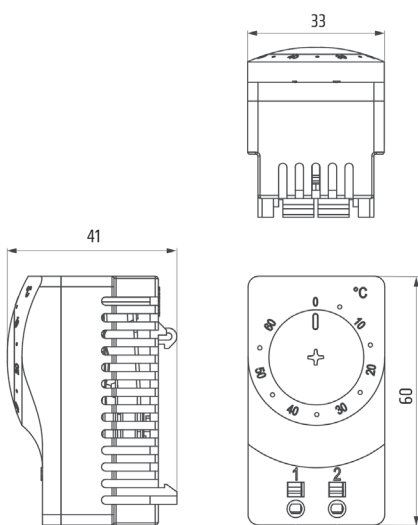

Connection diagrams

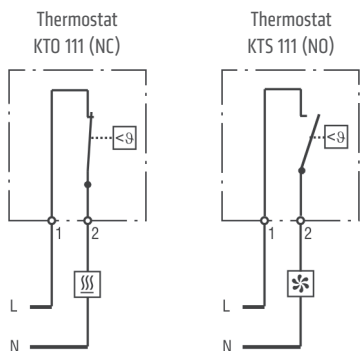

- Heater
- Filter fan, Cooling equipment, Signal device

Examples of connection

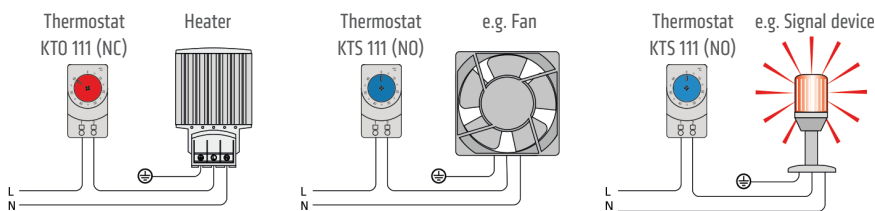

Setting range	Art. No. Contact breaker (NC)	Art. No. Contact maker (NO)	Switching current ² /capacity max			Approvals		
			AC 250 V	AC 120 V	DC 24-72 V			
0 to +60 °C	11100.0-00	11101.0-00	10 (2) A	15 (2) A	30 W	VDE	UL File No. E164102	EAC
-10 to +50 °C	11100.0-01	11101.0-01	10 (2) A	15 (2) A	30 W	VDE	UL File No. E164102	EAC
+20 to +80 °C	11100.0-02	11101.0-02	3 (2) A	3 (2) A	30 W	VDE	UL File No. E164102	EAC
+32 to +140 °F	11100.9-00	11101.9-00	10 (2) A	15 (2) A	30 W	VDE	UL File No. E164102	EAC
+14 to +122 °F	11100.9-01	11101.9-01	10 (2) A	15 (2) A	30 W	VDE	UL File No. E164102	EAC

² The level of switching current has an influence on the tolerance accuracy;



SCATTERGOOD & JOHNSON LTD

ELECTRICAL ENGINEERING & FLUID CONTROL DISTRIBUTORS

Est.1899

At Scattergood & Johnson Ltd, we pride ourselves on being a technical distributor to specialist industries.

Working with a range of quality product suppliers across a number of specialist markets, we are not your average 'box shifter' - we are your technical and supply chain partner.

We fully support every product we sell - for free! Our internal team and external sales engineers can answer any product or application question, no matter the complexity.

Backing up this technical ability is a range of 50,000+ products available from stock for nationwide next day delivery (same day if required!), or you can collect what you need from any of our trade counters around the UK.

Select your specialist interest below to learn more about how we can help.



Online, In Branch and On the Road - Scattergood & Johnson Ltd, there when you need us.

www.scatts.co.uk