

R88M-1□

# 1S servo motor

## Simplified machine design and maintenance

- 23-bit resolution encoder
- Compact and small motor size
- Multi-turn encoder design without mechanics: 16-bit, 65536 turns
- Battery-free absolute multi-turn encoder or incremental encoder
- Pre-assembled motor cables
- Designed for easy EMC compliance

## Ratings

- 230 VAC from 50 W to 1.5 kW  
(rated torque from 0.159 to 8.59 Nm)
- 400 VAC from 400 W to 15 kW  
(rated torque from 1.91 to 95.5 Nm)



## System configuration

(Refer to servo drive chapter)

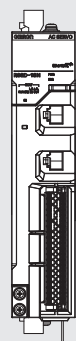

1S servo drive

### 1S servo motor (Flange size 80 mm or less)

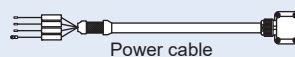

Power cable

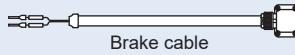

Brake cable

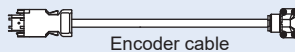

Encoder cable

**SYSMAC**  
always in control

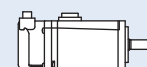

3000 rpm (50 W - 750 W)

### 1S servo motor (Flange size 100 mm or more)

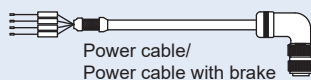

Power cable/  
Power cable with brake

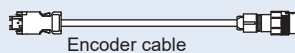

Encoder cable

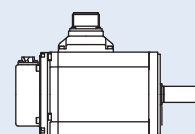

3000 rpm (1 kW - 5 kW)  
2000 rpm (400 W - 3 kW)  
1500 rpm (4 kW - 15 kW)  
1000 rpm (900 W - 3 kW)

Servo motor / Servo drive combination

1S servo motor						1S servo drive	
Appearance	Speed	Voltage	Rated torque	Capacity	Model		
	3000 min <sup>-1</sup>	230 V	0.159 Nm	50 W	R88M-1M05030T-□	R88D-1SN01H-ECT	
			0.318 Nm	100 W	R88M-1M10030(H/T)-□	R88D-1SN01H-ECT	
			0.637 Nm	200 W	R88M-1M20030(H/T)-□	R88D-1SN02H-ECT	
			1.27 Nm	400 W	R88M-1M40030(H/T)-□	R88D-1SN04H-ECT	
			2.39 Nm	750 W	R88M-1M75030(H/T)-□	R88D-1SN08H-ECT	
			3.18 Nm	1 kW	R88M-1L1K030(H/T)-□	R88D-1SN15H-ECT	
		400 V	4.77 Nm	1.5 kW	R88M-1L1K530(H/T)-□	R88D-1SN15H-ECT	
			2.39 Nm	750 W	R88M-1L75030C-□	R88D-1SN10F-ECT	
			3.18 Nm	1 kW	R88M-1L1K030C-□	R88D-1SN10F-ECT	
			4.77 Nm	1.5 kW	R88M-1L1K530C-□	R88D-1SN15F-ECT	
			6.37 Nm	2 kW	R88M-1L2K030C-□	R88D-1SN20F-ECT	
			9.55 Nm	3 kW	R88M-1L3K030C-□	R88D-1SN30F-ECT	
	2000 min <sup>-1</sup>	230 V	12.7 Nm	4 kW	R88M-1L4K030C-□	R88D-1SN55F-ECT	
			15.9 Nm	5 kW	R88M-1L5K030C-□	R88D-1SN55F-ECT	
			4.77 Nm	1 kW	R88M-1M1K020(H/T)-□	R88D-1SN15H-ECT	
			7.16 Nm	1.5 kW	R88M-1M1K520(H/T)-□	R88D-1SN15H-ECT	
			400 V	1.91 Nm	400 W	R88M-1M40020C-□	R88D-1SN06F-ECT
				2.86 Nm	600 W	R88M-1M60020C-□	R88D-1SN06F-ECT
		4.77 Nm		1 kW	R88M-1M1K020C-□	R88D-1SN10F-ECT	
		7.16 Nm		1.5 kW	R88M-1M1K520C-□	R88D-1SN15F-ECT	
		9.55 Nm		2 kW	R88M-1M2K020C-□	R88D-1SN20F-ECT	
		14.3 Nm		3 kW	R88M-1M3K020C-□	R88D-1SN30F-ECT	
		1500 min <sup>-1</sup>	400 V	25.5 Nm	4 kW	R88M-1M4K015C-□	R88D-1SN55F-ECT
				35 Nm	5.5 kW	R88M-1M5K515C-□	R88D-1SN55F-ECT
47.8 Nm	7.5 kW			R88M-1M7K515C-□	R88D-1SN75F-ECT		
70 Nm	11 kW			R88M-1M11K015C-□	R88D-1SN150F-ECT		
1000 min <sup>-1</sup>	230 V	95.5 Nm	15 kW	R88M-1M15K015C-□	R88D-1SN150F-ECT		
		8.59 Nm	900 W	R88M-1M90010T-□	R88D-1SN15H-ECT		
	400 V	8.59 Nm	900 W	R88M-1M90010C-□	R88D-1SN10F-ECT		
		19.1 Nm	2 kW	R88M-1M2K010C-□	R88D-1SN20F-ECT		
			28.7 Nm	3 kW	R88M-1M3K010C-□	R88D-1SN30F-ECT	

Note: For servo motor and cable part numbers, refer to ordering information at the end of this chapter.

Note: Refer to the servo drive chapter for drive options selection and detailed specifications.

Type designation

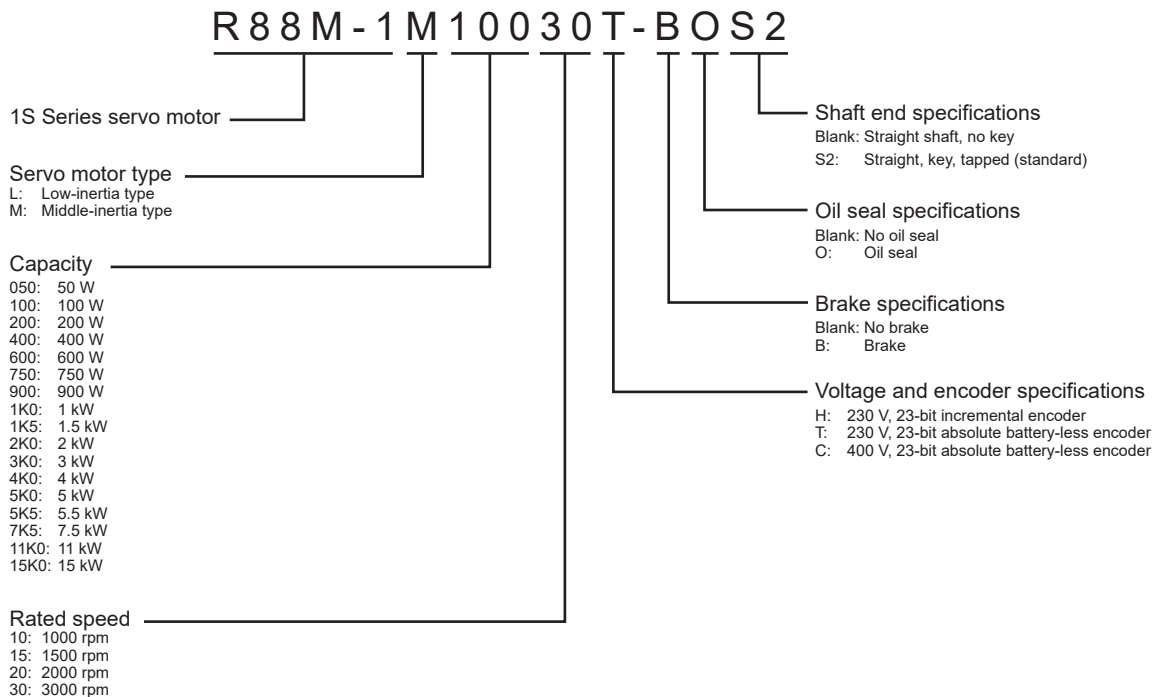

Specifications

3000 r/min servo motors, 230 V

Ratings and specifications

Voltage		230 V							
Servo motor model: R88M-1□	23-bit incremental encoder	–	M10030H-□	M20030H-□	M40030H-□	M75030H-□	L1K030H-□	L1K530H-□	
	23-bit absolute encoder	M05030T-□	M10030T-□	M20030T-□	M40030T-□	M75030T-□	L1K030T-□	L1K530T-□	
Rated output	W	50	100	200	400	750	1000	1500	
Rated torque	Nm	0.159	0.318	0.637	1.27	2.39	3.18	4.77	
Instantaneous peak torque	Nm	0.56	1.11	2.2	4.5	8.4	9.55	14.3	
Rated current	A (rms)	0.67	0.84	1.5	2.5	4.6	5.2	8.8	
Instantaneous max. current	A (rms)	2.6	3.1	5.6	9.1	16.9	16.9	28.4	
Rated speed	min <sup>-1</sup>	3000							
Max. speed	min <sup>-1</sup>	6000					5000		
Torque constant	N·m/A	0.25	0.42	0.48	0.56	0.59	0.67	0.58	
Rotor moment of inertia	kg·m <sup>2</sup> ×10 <sup>-4</sup> (without brake)	0.0418	0.089	0.2232	0.4452	1.8242	2.1042		
	kg·m <sup>2</sup> ×10 <sup>-4</sup> (with brake)	0.0496	0.0968	0.2832	0.5052	2.0742	2.5542		
Electrical time constant	ms	0.67	0.83	2.4	2.6	3.3	5.9	6.1	
Allowable radial load	N	68			245		490		
Allowable thrust load	N	58			88		196		
Weight	kg (without brake)	0.35	0.52	1.0	1.4	2.9	5.7		
	kg (with brake)	0.59	0.77	1.3	1.9	3.9	7.4		
Brake specifications	Excitation voltage* <sup>1</sup>	24 VDC ±10%							
	Holding brake moment of inertia J	kg·m <sup>2</sup> ×10 <sup>-4</sup>		0.0078		0.06		0.25	0.45
	Current consumption (at 20°C)	A		0.27		0.32		0.37	0.70
	Static friction torque	Nm (minimum)		0.32		1.37		2.55	9.3
Basic specifications	Insulation class	Type F							
	Ambient operating/storage temperature	0 to 40°C/-20 to 65°C							
	Ambient operating/storage humidity	20 to 90% (non-condensing)							
	Atmosphere	No corrosive gases							
	Insulation resistance	10 MΩ min. at 500 VDC between the power terminals and FG terminal							
	Vibration resistance	Vibration acceleration of 49 m/s <sup>2</sup>							
	Impact resistance	Acceleration of 98 m/s <sup>2</sup> max. 3 times each in X, Y and Z directions							
	Enclosure	IP67 (except for through-shaft parts when connectors are inserted)							

\*1 This is a non-excitable brake (it is released when excitation voltage is applied).

Torque-speed characteristics

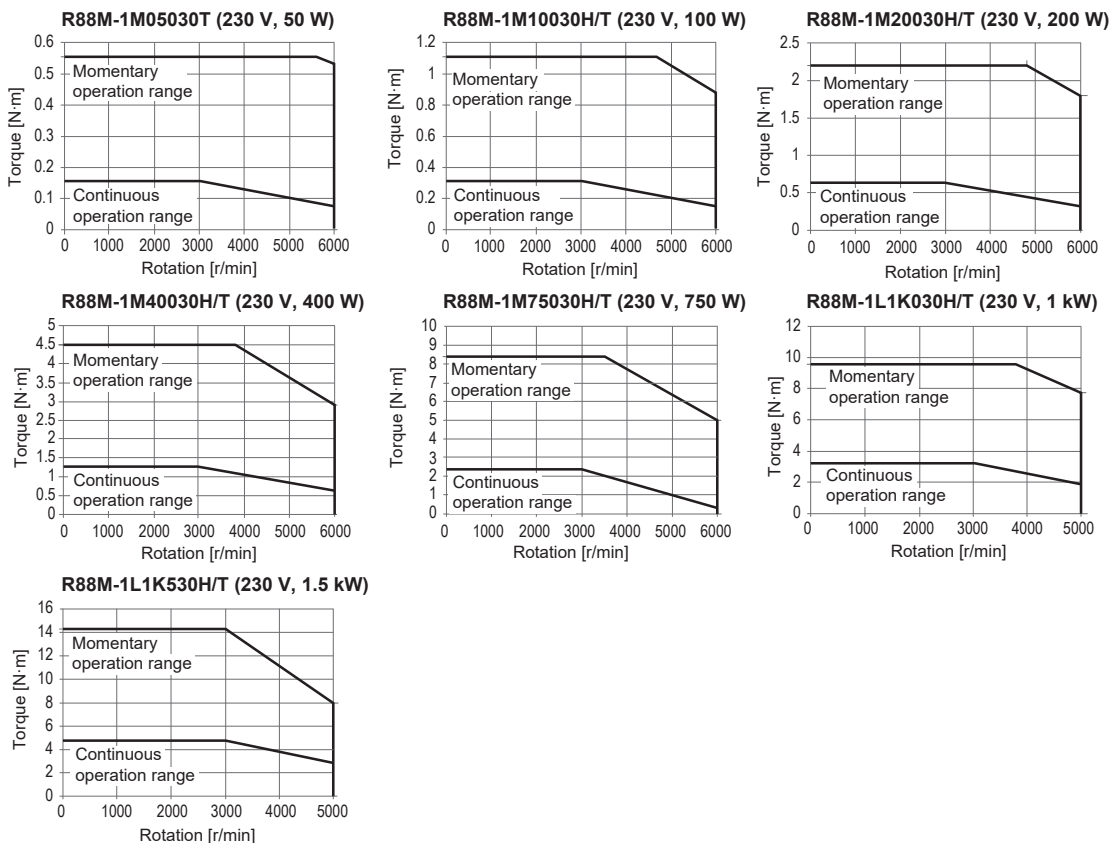

3000 r/min servo motors, 400 V

Ratings and specifications

Voltage		400 V								
Servo motor model: R88M-1□	23-bit absolute encoder	L75030C-□	L1K030C-□	L1K530C-□	L2K030C-□	L3K030C-□	L4K030C-□	L5K030C-□		
Rated output	W	750	1000	1500	2000	3000	4000	5000		
Rated torque	Nm	2.39	3.18	4.77	6.37	9.55	12.7	15.9		
Instantaneous peak torque	Nm	7.16	9.55	14.3	19.1	28.7	38.2	47.7		
Rated current	A (rms)	3.0	3.0	4.5	6.3	8.7	12.8	13.6		
Instantaneous max. current	A (rms)	9.6	9.6	14.1	19.8	27.7	42.4			
Rated speed	min <sup>-1</sup>	3000								
Max. speed	min <sup>-1</sup>	5000								
Torque constant	N·m/A	0.91	1.17	1.17	1.15	1.23	1.11	1.32		
Rotor moment of inertia	kg·m <sup>2</sup> ×10 <sup>-4</sup> (without brake)	1.3042	2.1042		2.4042	6.8122	8.8122	10.6122		
	kg·m <sup>2</sup> ×10 <sup>-4</sup> (with brake)	1.7542	2.5542		2.8542	7.3122	11.3122	13.1122		
Electrical time constant	ms	4.3	5.9		6.3	11.0	12.0	13.0		
Allowable radial load	N	490						880		
Allowable thrust load	N	196						343		
Weight	kg (without brake)	4.1	5.7		6.4	11.5	13.5	16.0		
	kg (with brake)	5.8	7.4		8.1	12.5	16.0	18.5		
Brake specifications	Excitation voltage* <sup>1</sup>	24 VDC ±10%								
	Holding brake moment of inertia J	kg·m <sup>2</sup> ×10 <sup>-4</sup> 0.45				0.50		2.5		
	Current consumption (at 20°C)	A 0.70				0.66		0.6		
	Static friction torque	Nm (minimum) 9.3				12.0		16.0		
Basic specifications	Insulation class	Type F								
	Ambient operating/storage temperature	0 to 40°C/-20 to 65°C								
	Ambient operating/storage humidity	20 to 90% (non-condensing)								
	Atmosphere	No corrosive gases								
	Insulation resistance	10 MΩ min. at 500 VDC between the power terminals and FG terminal								
	Vibration resistance	Vibration acceleration of 49 m/s <sup>2</sup>								
	Impact resistance	Acceleration of 98 m/s <sup>2</sup> max. 3 times each in X, Y and Z directions								
	Enclosure	IP67 (except for through-shaft parts when connectors are inserted)								

\*<sup>1</sup> This is a non-excitabile brake (it is released when excitation voltage is applied).

Torque-speed characteristics

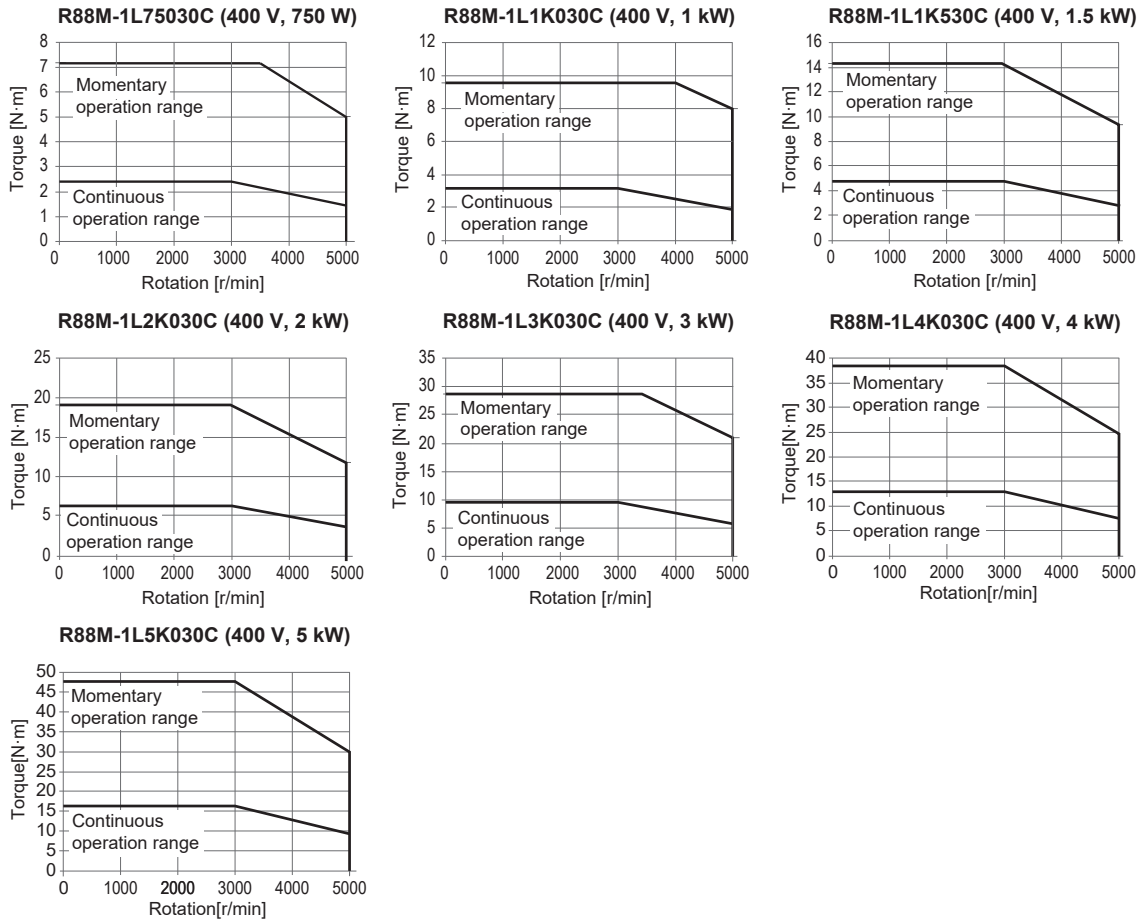

2000 r/min servo motors, 230 V/400 V

Ratings and specifications

Voltage		230 V		400 V						
Servo motor model: R88M-1□	23-bit incremental encoder	M1K020H-□	M1K520H-□							
	23-bit absolute encoder	M1K020T-□	M1K520T-□	M40020C-□	M60020C-□	M1K020C-□	M1K520C-□	M2K020C-□	M3K020C-□	
Rated output	W	1000	1500	400	600	1000	1500	2000	3000	
Rated torque	Nm	4.77	7.16	1.91	2.86	4.77	7.16	9.55	14.3	
Instantaneous peak torque	Nm	14.3	21.5	5.73	8.59	14.3	21.5	28.7	43.0	
Rated current	A (rms)	5.2	8.6	1.1	1.6	2.9	4.1	5.7	8.6	
Instantaneous max. current	A (rms)	16.9	28.4	3.9	5.5	9.4	13.5	19.8	28.3	
Rated speed	min <sup>-1</sup>	2000								
Max. speed	min <sup>-1</sup>	3000								
Torque constant	N·m/A	0.93	0.83	1.75	1.84	1.69	1.75		1.74	
Rotor moment of inertia	kg·m <sup>2</sup> ×10 <sup>-4</sup> (without brake)	6.0042	9.0042	2.5042	3.9042	6.0042	9.0042	12.2042	15.3122	
	kg·m <sup>2</sup> ×10 <sup>-4</sup> (with brake)	6.5042	9.5042	2.8472	4.2472	6.5042	9.5042	12.7042	17.4122	
Electrical time constant	ms	13.0	15.0	6.8	7.8	13.0	13.0	14.0	20.0	
Allowable radial load	N	490							784	
Allowable thrust load	N	196							343	
Weight	kg (without brake)	6.6	8.5	3.9	4.7	6.6	8.5	10.0	12.0	
	kg (with brake)	8.6	10.5	4.8	5.8	8.6	10.5	12.0	15.0	
Brake specifications	Excitation voltage <sup>*1</sup>	24 VDC ±10%								
	Holding brake moment of inertia J	kg·m <sup>2</sup> ×10 <sup>-4</sup>		0.5		0.343		0.5		2.1
	Current consumption (at 20°C)	A		0.51		0.3		0.51		0.66
	Static friction torque	Nm (minimum)		9.0		3.92		9.0		12.0
Basic specifications	Insulation class	Type F								
	Ambient operating/storage temperature	0 to 40°C/-20 to 65°C								
	Ambient operating/storage humidity	20 to 90% (non-condensing)								
	Atmosphere	No corrosive gases								
	Insulation resistance	10 MΩ min. at 500 VDC between the power terminals and FG terminal								
	Vibration resistance	Vibration acceleration of 49 m/s <sup>2</sup>								
	Impact resistance	Acceleration of 98 m/s <sup>2</sup> max. 3 times each in X, Y and Z directions								
Enclosure	IP67 (except for through-shaft parts when connectors are inserted)									

\*1 This is a non-excitabile brake (it is released when excitation voltage is applied).

Torque-speed characteristics

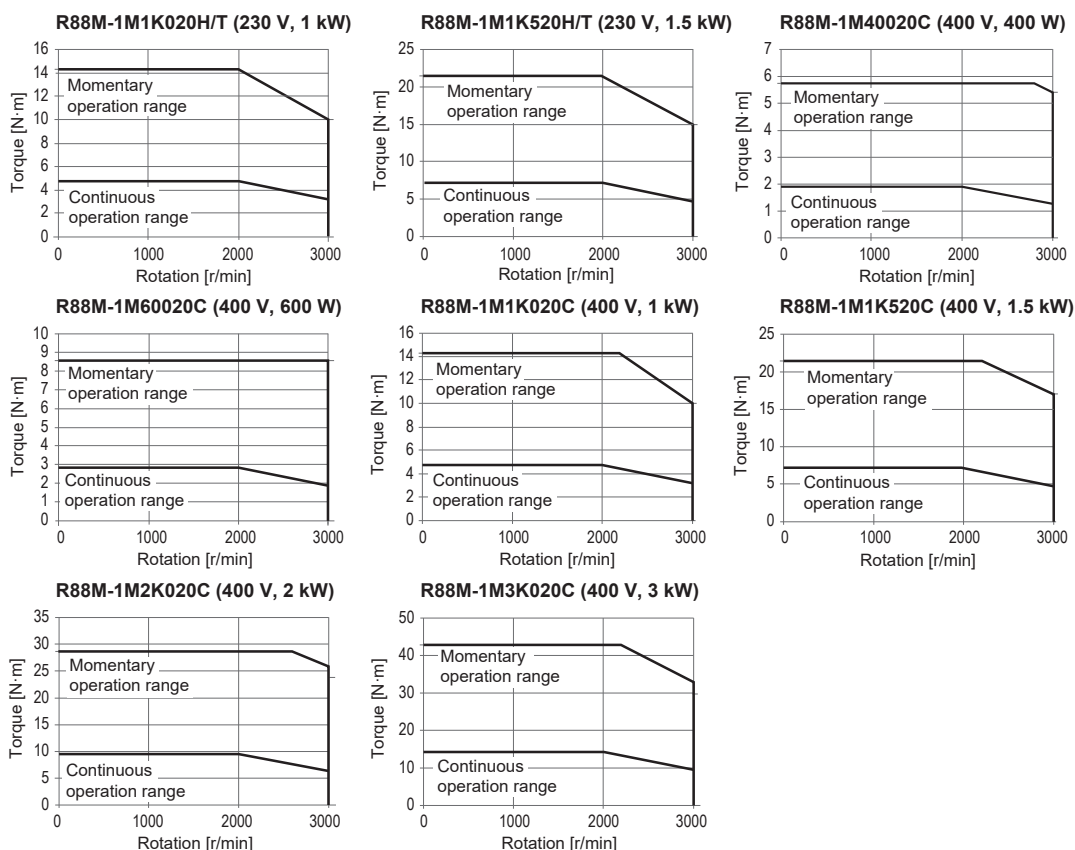

1500 r/min servo motors, 400 V

Ratings and specifications

Voltage		400 V					
Servo motor model: R88M-1□	23-bit absolute encoder	M4K015C-□	M5K515C-□	M7K515C-□	M11K015C-□	M15K015C-□	
Rated output	W	4,000	5,500	7,500	11,000	15,000	
Rated torque	Nm	25.5	35.0	47.8	70	95.5	
Instantaneous peak torque	Nm	75	95	119	175	224	
Rated current	A (rms)	12.8	14.0	22.0	31.4	33.3	
Instantaneous max. current	A (rms)	42.4		56.5	80.7	81.2	
Rated speed	min <sup>-1</sup>	1,500					
Max. speed	min <sup>-1</sup>	3,000				2,000	
Torque constant	N·m/A (rms)	2.07	2.68	2.49	2.6	3.27	
Rotor moment of inertia	kg·m <sup>2</sup> ×10 <sup>-4</sup> (without brake)	54.0122	77.0122	113.0122	229.0122	340.0122	
	kg·m <sup>2</sup> ×10 <sup>-4</sup> (with brake)	60.0122	83.0122	118.0122	253.0122	365.0122	
Electrical time constant	ms	18	19	23	29		
Allowable radial load	N	1,200	1,470		2,500		
Allowable thrust load	N	343	490	686			
Weight	kg (without brake)	21	29	39	63	85	
	kg (with brake)	26	34	45	73	99	
Brake specifications	Excitation voltage <sup>*1</sup>	24 VDC ±10%					
	Holding brake moment of inertia J	6.0		5.0	24.0	25.0	
	Current consumption (at 20°C)	1.0		1.4	1.7	0.92	
	Static friction torque	Nm (minimum)		32 min.	42 min.	54.9 min.	90 min.
Basic specifications	Insulation class	Class F					
	Ambient operating/storage temperature	0 to 40°C/-20 to 65°C					
	Ambient operating/storage humidity	20 to 90% (non-condensing)					
	Atmosphere	No corrosive gases					
	Insulation resistance	10 MΩ min. at 500 VDC between the power terminals and FG terminal					
	Vibration resistance	Vibration acceleration of 49 m/s <sup>2</sup>					
	Impact resistance	Acceleration of 98 m/s <sup>2</sup> max. 3 times each in X, Y and Z directions					
Enclosure	IP67 (except for through-shaft parts when connectors are inserted)						

\*1 This is a non-excitable brake (it is released when excitation voltage is applied).

Torque-speed characteristics

R88M-1M4K015C (400 V, 4 kW)

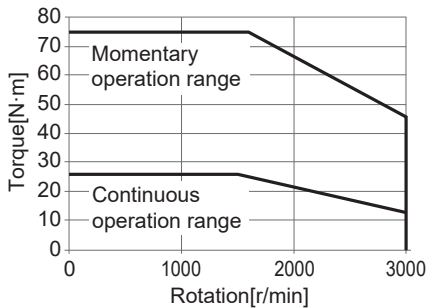

R88M-1M5K515C (400 V, 5.5 kW)

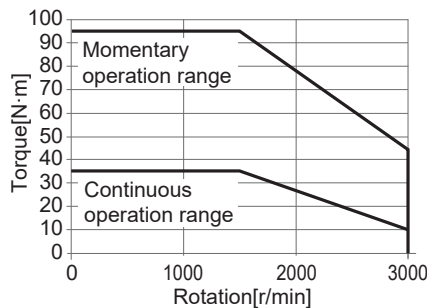

R88M-1M7K515C (400 V, 7.5 kW)

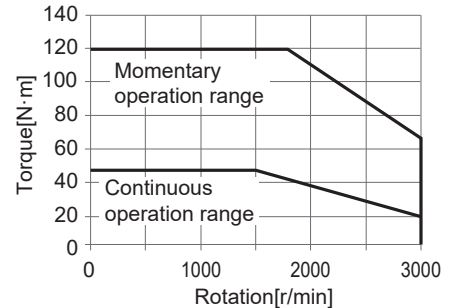

R88M-1M11K015C (400 V, 11 kW)

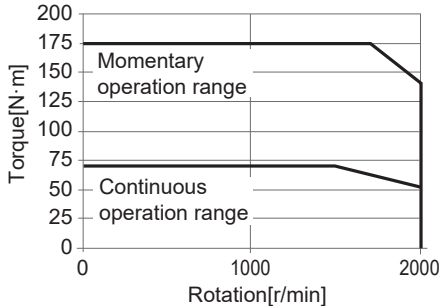

R88M-1M15K015C (400 V, 15 kW)

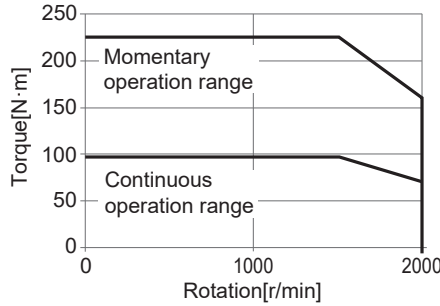

1000 r/min servo motors, 230 V/400 V

Ratings and specifications

Voltage		230 V		400 V	
Servo motor model: R88M-1□	23-bit absolute encoder	M90010T-□	M90010C-□	M2K010C-□	M3K010C-□
Rated output	W	900		2000	3000
Rated torque	Nm	8.59		19.1	28.7
Instantaneous peak torque	Nm	19.3		47.7	71.7
Rated current	A (rms)	6.7	3.6	7.1	10.6
Instantaneous max. current	A (rms)	16.9	9.0	19.5	27.7
Rated speed	min <sup>-1</sup>	1000			
Max. speed	min <sup>-1</sup>	2000			
Torque constant	N·m/A	1.28	2.41	3.00	2.97
Rotor moment of inertia	kg·m <sup>2</sup> ×10 <sup>-4</sup> (without brake)	9.0042		40.0122	68.0122
	kg·m <sup>2</sup> ×10 <sup>-4</sup> (with brake)	9.5042		45.1122	73.1122
Electrical time constant	ms	15.0	13.0	16.0	19.0
Allowable radial load	N	686		1176	1470
Allowable thrust load	N	196		490	
Weight	kg (without brake)	8.5		18.0	28.0
	kg (with brake)	10.5		22.0	33.0
Brake specifications	Excitation voltage <sup>*1</sup>	24 VDC ±10%			
	Holding brake moment of inertia J	kg·m <sup>2</sup> ×10 <sup>-4</sup>	0.5		5.1
	Current consumption (at 20°C)	A	0.51	1.2	1.0
	Static friction torque	Nm (minimum)	9.0		22.0
Basic specifications	Insulation class	Type F			
	Ambient operating/storage temperature	0 to 40°C/-20 to 65°C			
	Ambient operating/storage humidity	20 to 90% (non-condensing)			
	Atmosphere	No corrosive gases			
	Insulation resistance	10 MΩ min. at 500 VDC between the power terminals and FG terminal			
	Vibration resistance	Vibration acceleration of 49 m/s <sup>2</sup>			
	Impact resistance	Acceleration of 98 m/s <sup>2</sup> max. 3 times each in X, Y and Z directions			
Enclosure	IP67 (except for through-shaft parts when connectors are inserted)				

\*1 This is a non-excitabile brake (it is released when excitation voltage is applied).

Torque-speed characteristics

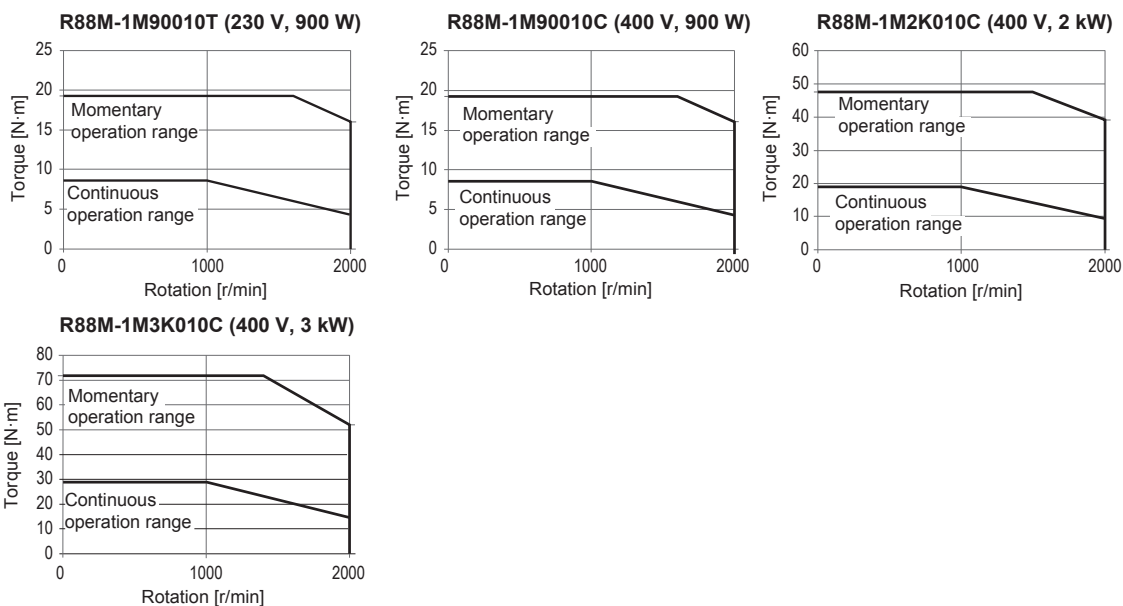

Dimensions

Servo motors

Type 3000 r/min motors (230 V, 50 W)

Dimensions (mm)	Without brake	With brake	Approx. mass (kg)	
Model: R88M-1□	LL	LL	Without brake	With brake
M05030T-□S2	67.5	103.5	0.35	0.59

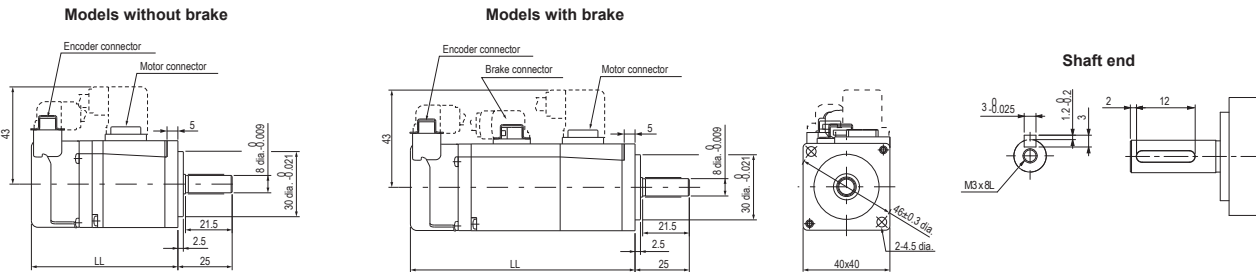

Type 3000 r/min motors (230 V, 100 W)

Dimensions (mm)	Without brake	With brake	Approx. mass (kg)	
Model: R88M-1□	LL	LL	Without brake	With brake
M10030(H/T)-□S2	90	126	0.52	0.77

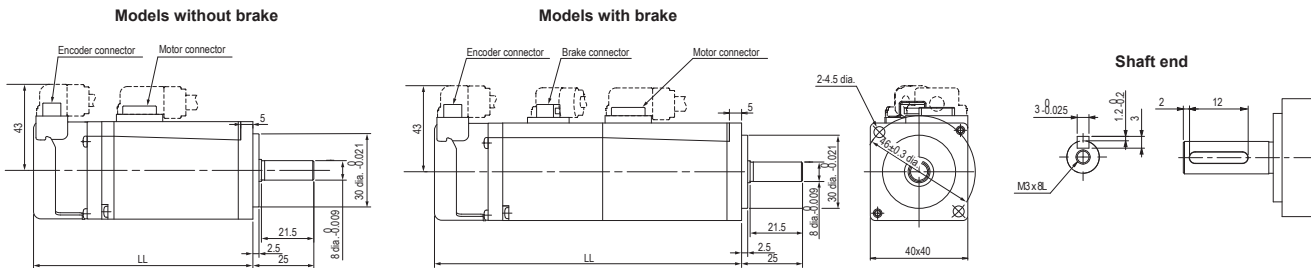

Type 3000 r/min motors (230 V, 200 W to 750 W)

Dimensions (mm)	Without brake		With brake		LR	Flange surface					Shaft end						Approx. mass (kg)		
	LL	KL1	LL	KL1		LB	LC	LD	LG	LZ	S	QA	QK	W	U	T	Tap x depth	Without brake	With brake
M20030(H/T)-□S2	79.5	52.6	107.5	52.6	30	50 dia. <sup>0</sup> <sub>-0.025</sub>	60	70	6	4.5	11 dia. <sup>0</sup> <sub>-0.011</sub>	2	20	4 <sup>0</sup> <sub>-0.03</sub>	1.5 <sup>0</sup> <sub>-0.2</sub>	4	M4 x 10L	1.0	1.3
M40030(H/T)-□S2	105.5		133.5								14 dia. <sup>0</sup> <sub>-0.011</sub>			5 <sup>0</sup> <sub>-0.03</sub>	2 <sup>0</sup> <sub>-0.2</sub>	5	M5 x 12L	1.4	1.9
M75030(H/T)-□S2	117.3	63.2	153	63.2	35	70 dia. <sup>0</sup> <sub>-0.03</sub>	80	90	8	6	19 dia. <sup>0</sup> <sub>-0.013</sub>	3	24	6 <sup>0</sup> <sub>-0.03</sub>	2.5 <sup>0</sup> <sub>-0.2</sub>	6		2.9	3.9

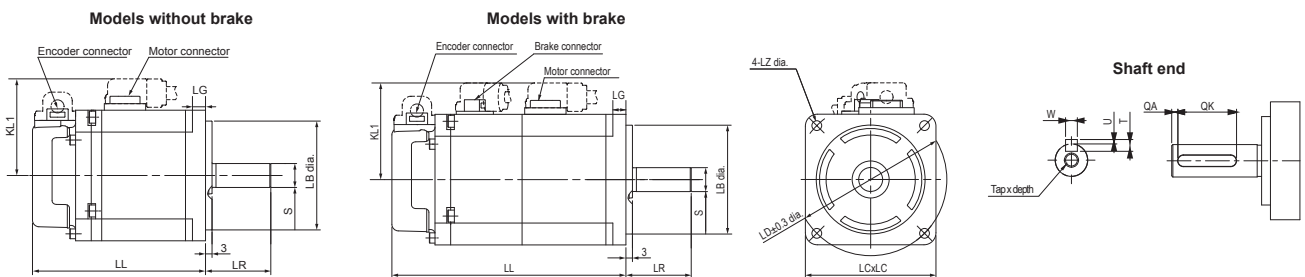

Type 3000 r/min motors (230 V, 1 kW to 1.5 kW / 400 V, 750 W to 3 kW)

Dimensions (mm)	Without brake				With brake				LR	Flange surface						Shaft end					Approx. mass (kg)			
	Model: R88M-1□	LL	KB1	KB2	KL1	LL	KB1	KB2		KL1	LB	LC	LD	LE	LG	LZ	S	QA	QK	W	U	T	Tap x depth	Without brake
L1K030(H/T)-□S2	168	85	153	97	209	85	194	97	55	95 dia. $0_{-0.035}$	100	115	3	10	9	19 dia. $0_{-0.013}$	3	42	6 $0_{-0.03}$	2.5 $0_{-0.2}$	6	M5 x 12L	5.7	7.4
L1K530(H/T)-□S2					180	56	165	104														4.1	5.8	
L75030C-□S2	139	56	124		209	85	194															5.7	7.4	
L1K030C-□S2	168	85	153		220	96	205															6.4	8.1	
L1K530C-□S2	179	96	164																					
L2K030C-□S2	179	96	164		220	96	205																	
L3K030C-□S2	184	112	169	116	230	112	215	119		110 dia. $0_{-0.035}$	130	145	4	12	9	22 dia. $0_{-0.013}$		8 $0_{-0.036}$	3 $0_{-0.4}$	7		11.5	12.5	

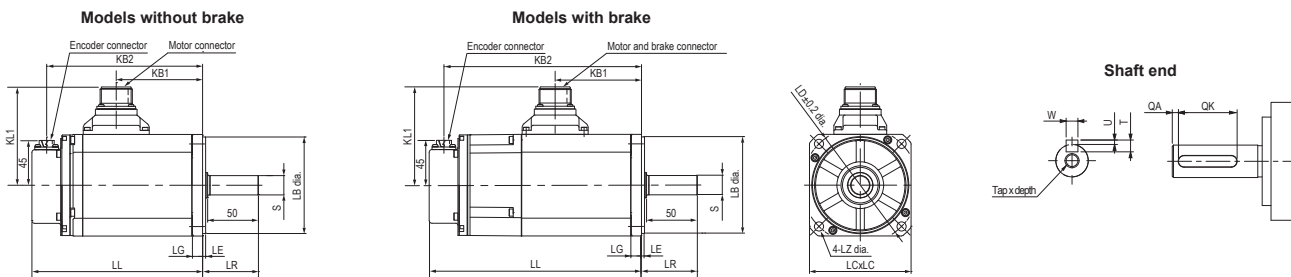

Type 3000 r/min motors (400 V, 4 kW to 5 kW)

Dimensions (mm)	Without brake		With brake		Approx. mass (kg)		
	Model: R88M-1□	LL	KB1	LL	KB1	Without brake	With brake
L4K030C-□S2		208	128	251	128	13.5	16.0
L5K030C-□S2		232	152	275	152	16.0	18.5

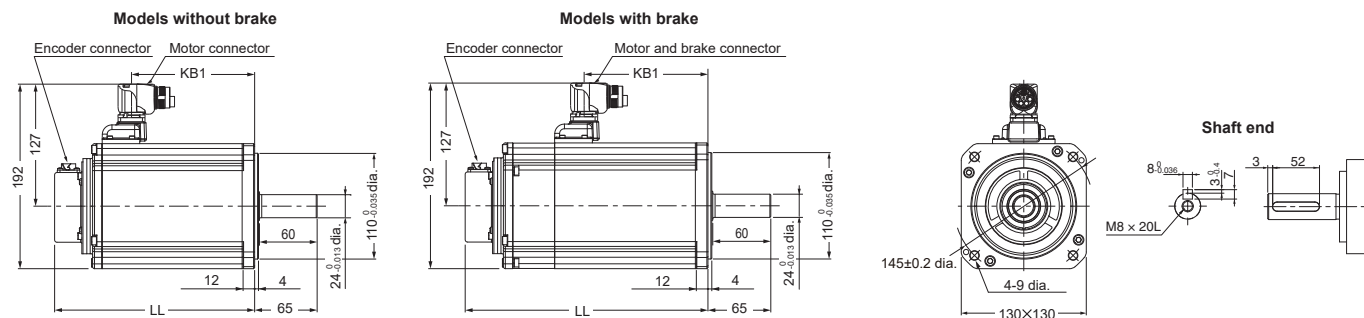

Type 2000 r/min motors (400 V, 400 W to 600 W)

Dimensions (mm)	Without brake				With brake				Approx. mass (kg)	
	Model: R88M-1□	LL	KB1	KB2	KL1	LL	KB1	KB2	KL1	Without brake
M40020C-□S2	134.8	52	120.5	97	152.3	52	138	104	3.9	4.8
M60020C-□S2	151.8	69	137.5		169.3	69	155		4.7	5.8

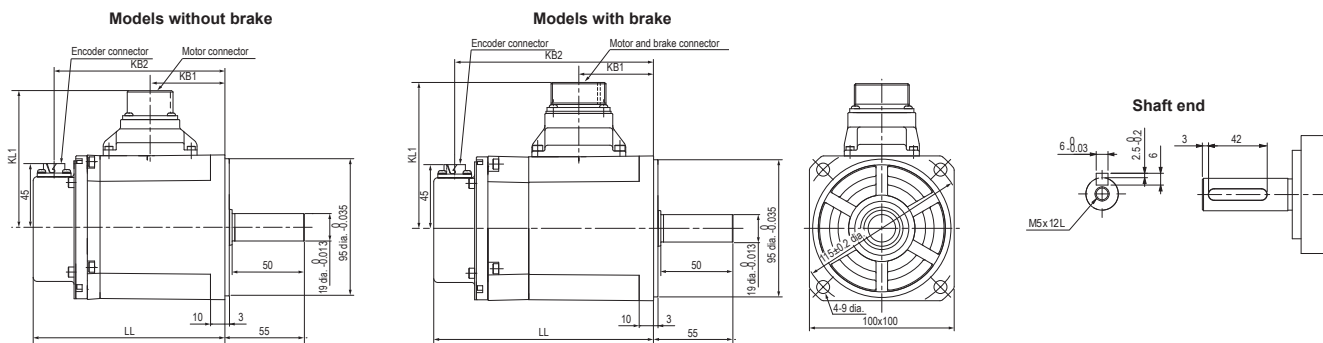

Type 2000 r/min motors (230 V, 1 kW to 1.5 kW / 400 V, 1 kW to 3 kW)

Dimensions (mm)	Without brake					With brake					LR	Shaft end							Approx. mass (kg)		
	LL	KB1	KB2	KL1	KL2	LL	KB1	KB2	KL1	KL2		S	Q	QA	QK	W	U	T	Tap x depth	Without brake	With brake
M1K020(H/T)-□S2	120.5	63	109	76	118	162	63	149	76	118	55	22 dia. <sup>0</sup> <sub>-0.013</sub>	50	3	42	8 <sup>0</sup> <sub>-0.036</sub>	3 <sup>0</sup> <sub>-0.4</sub>	7	M5 x 12L	6.6	8.6
M1K520(H/T)-□S2	138	79	125			179	79	166												8.5	10.5
M1K020C-□S2	120.5	63	109			162	64	150		119										6.6	8.6
M1K520C-□S2	138	79	125			179	81	167												8.5	10.5
M2K020C-□S2	160	98	148			201	99	189												10.0	12.0
M3K020C-□S2	191	119	176	45	116	234	118	219	45	119	65	24 dia. <sup>0</sup> <sub>-0.013</sub>	60		52				M8 x 20L	12.0	15.0

Models without brake

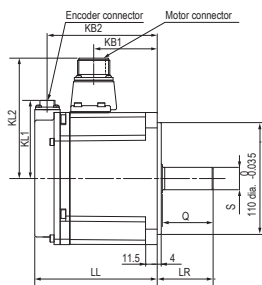

Models with brake

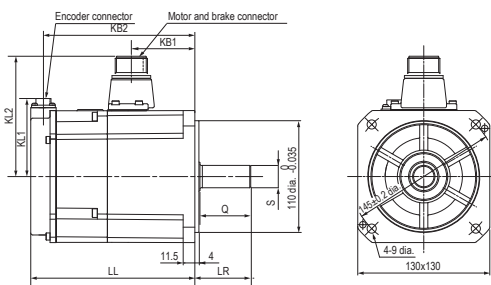

Shaft end

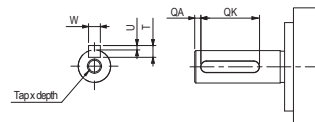

Type 1500 r/min motors (400 V, 4 kW)

Dimensions (mm)	Without brake		With brake		Approx. mass (kg)	
	LL	KB1	LL	KB1	Without brake	With brake
M4K015C-□S2	176	102	223	102	21.0	26.0

Models without brake

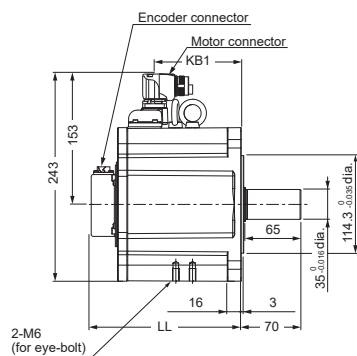

Models with brake

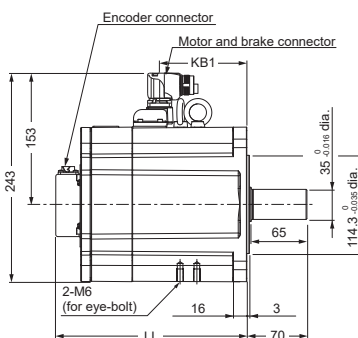

Eye-bolt (2-M6)

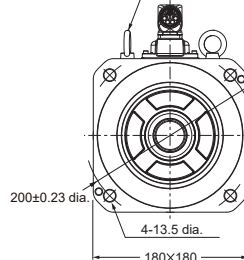

Shaft end

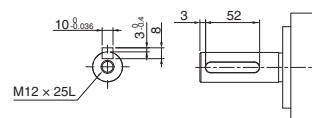

Type 1500 r/min motors (400 V, 5.5 kW to 7.5 kW)

Dimensions (mm)	Without brake		With brake		Approx. mass (kg)	
	LL	KB1	LL	KB1	Without brake	With brake
M5K515C-□S2	248	174	295	174	29.0	34.0
M7K515C-□S2	295	221	352	221	39.0	45.0

Models without brake

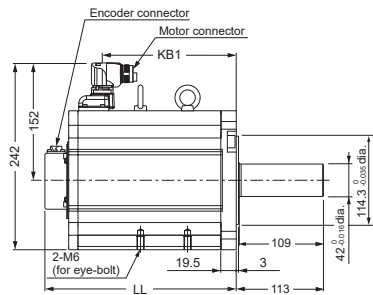

Models with brake

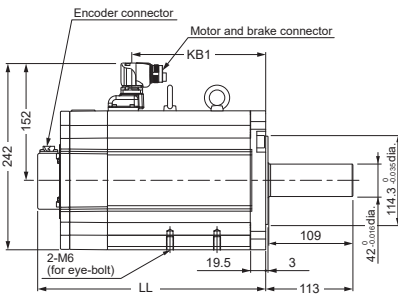

Eye-bolt (2-M6)

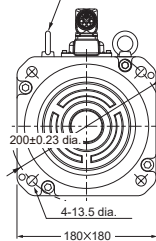

Shaft end

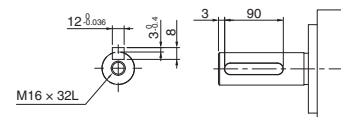

Type 1500 r/min motors (400 V, 11 kW to 15 kW)

Dimensions (mm)	Without brake			With brake		Approx. mass (kg)	
	Model: R88M-1□	LL	L2	KB1	LL	KB1	Without brake
M11K015C-□S2	319	330	249	382	249	63.0	73.0
M15K015C-□S2	397	408	327	493	327	85.0	99.0

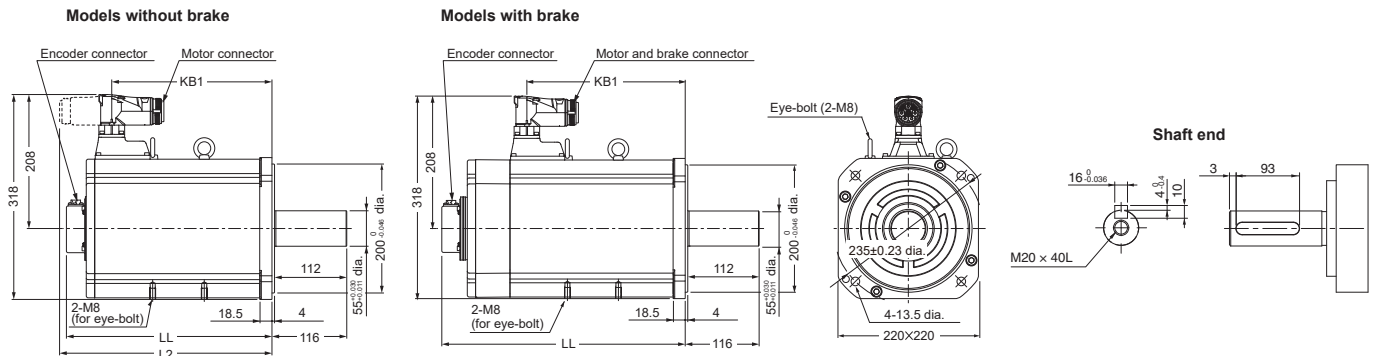

Type 1000 r/min motors (230 V, 900 W / 400 V, 900 W)

Dimensions (mm)	Without brake					With brake					Approx. mass (kg)	
	Model: R88M-1□	LL	KB1	KB2	KL1	KL2	LL	KB1	KB2	KL1	KL2	Without brake
M90010T-□S2	138	79	125	76	118	179	79	166	76	118	8.5	10.5
M90010C-□S2							81	167		117		

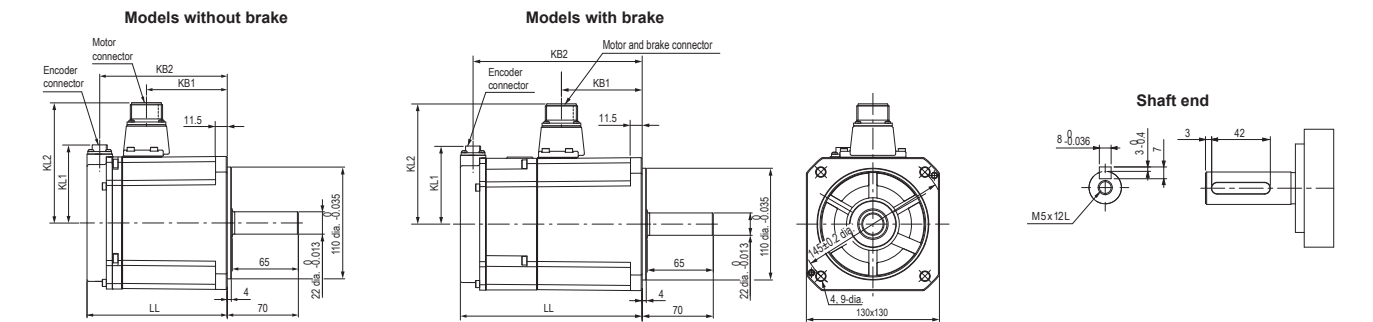

Type 1000 r/min motors (400 V, 2 kW)

Dimensions (mm)	Without brake					With brake					Approx. mass (kg)	
	Model: R88M-1□	LL	KB1	KB2	KL1	KL2	LL	KB1	KB2	KL1	KL2	Without brake
M2K010C-□S2	159	93	145	45	141	206	92	191	45	144	18.0	22.0

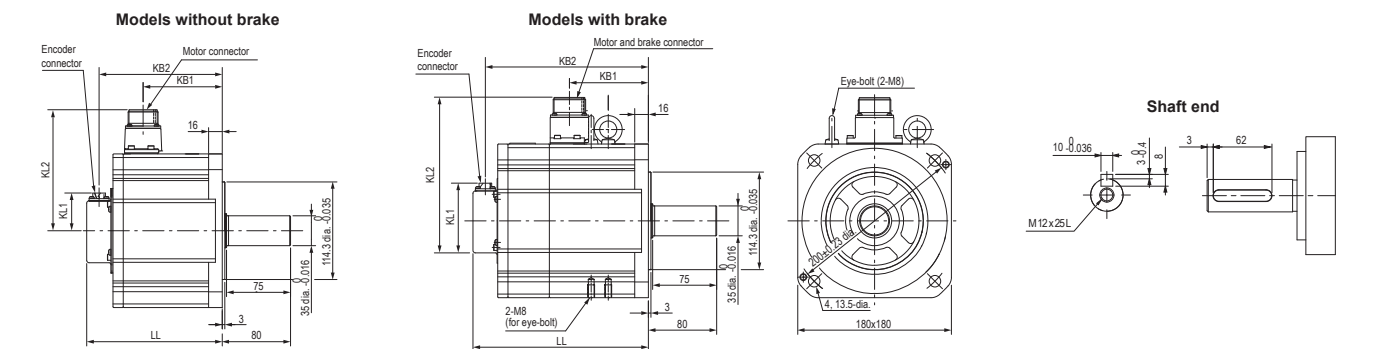

Type 1000 r/min motors (400 V, 3 kW)

Dimensions (mm)	Without brake					With brake					Approx. mass (kg)	
	LL	KB1	KB2	KL1	KL2	LL	KB1	KB2	KL1	KL2	Without brake	With brake
Model: R88M-1□												
M3K010C-□S2	228	162	213	45	141	274	162	260	45	144	28.0	33.0

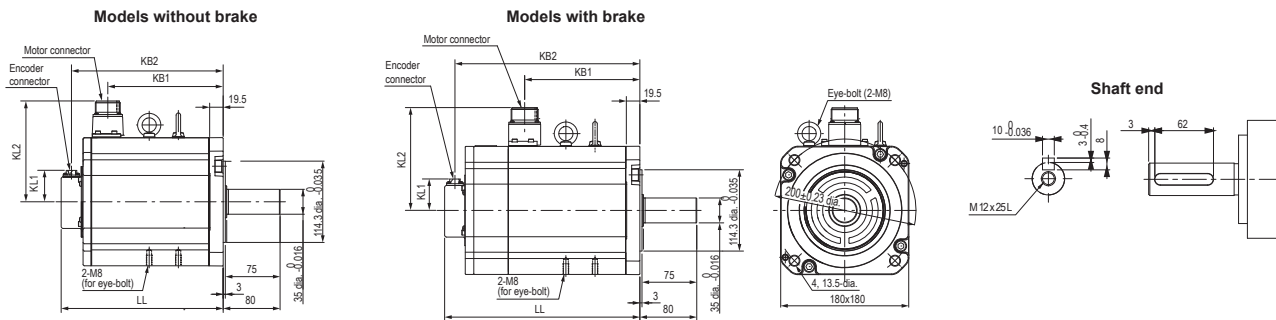

Ordering information

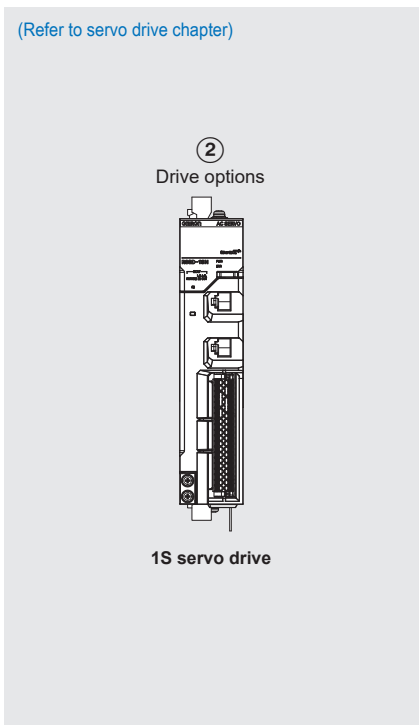

1S servo motor (Flange size 80 mm or less)

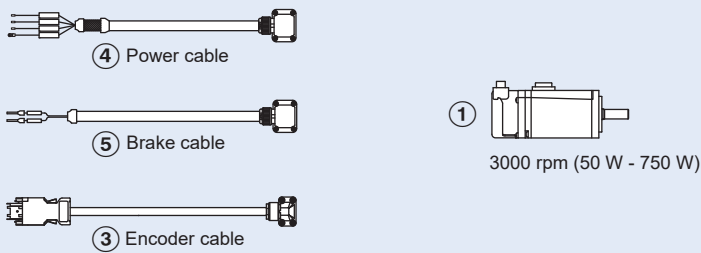

1S servo motor (Flange size 100 mm or more)

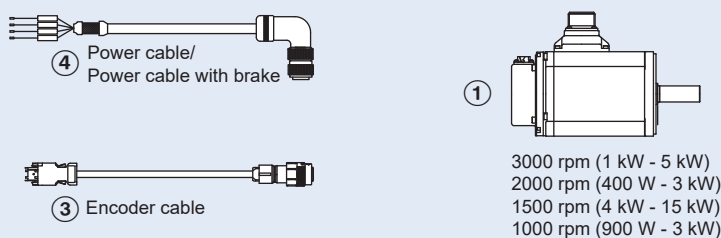

Servo motors

① Select motor from R88M-1□ family using motor tables in next pages.

Servo drives

② Refer to the 1S servo drive chapter for detailed drive specifications and selection of drive accessories.

Servo motors

Servo motors 3000 r/min (100 W to 5 kW)

Symbol	Specifications						Model	Compatible 1S servo drive
	Voltage	Encoder and design		Rated torque	Capacity	Flange size		
①	230 V	Incremental encoder (23-bit)	Without brake	0.318 Nm	100 W	40 mm	R88M-1M10030H-S2	R88D-1SN01H-ECT
				0.637 Nm	200 W	60 mm	R88M-1M20030H-S2	R88D-1SN02H-ECT
				1.27 Nm	400 W		R88M-1M40030H-S2	R88D-1SN04H-ECT
				2.39 Nm	750 W	80 mm	R88M-1M75030H-S2	R88D-1SN08H-ECT
				3.18 Nm	1 kW	100 mm	R88M-1L1K030H-S2	R88D-1SN15H-ECT
				4.77 Nm	1.5 kW		R88M-1L1K530H-S2	R88D-1SN15H-ECT
			With brake	0.318 Nm	100 W	40 mm	R88M-1M10030H-BS2	R88D-1SN01H-ECT
				0.637 Nm	200 W	60 mm	R88M-1M20030H-BS2	R88D-1SN02H-ECT
				1.27 Nm	400 W		R88M-1M40030H-BS2	R88D-1SN04H-ECT
				2.39 Nm	750 W	80 mm	R88M-1M75030H-BS2	R88D-1SN08H-ECT
				3.18 Nm	1 kW	100 mm	R88M-1L1K030H-BS2	R88D-1SN15H-ECT
				4.77 Nm	1.5 kW		R88M-1L1K530H-BS2	R88D-1SN15H-ECT
		Absolute encoder (23-bit)	Without brake	0.159 Nm	50 W	40 mm	R88M-1M05030T-S2	R88D-1SN01H-ECT
				0.318 Nm	100 W		R88M-1M10030T-S2	R88D-1SN01H-ECT
				0.637 Nm	200 W	60 mm	R88M-1M20030T-S2	R88D-1SN02H-ECT
				1.27 Nm	400 W		R88M-1M40030T-S2	R88D-1SN04H-ECT
				2.39 Nm	750 W	80 mm	R88M-1M75030T-S2	R88D-1SN08H-ECT
				3.18 Nm	1 kW	100 mm	R88M-1L1K030T-S2	R88D-1SN15H-ECT
			With brake	0.159 Nm	50 W	40 mm	R88M-1M05030T-BS2	R88D-1SN01H-ECT
				0.318 Nm	100 W		R88M-1M10030T-BS2	R88D-1SN01H-ECT
				0.637 Nm	200 W	60 mm	R88M-1M20030T-BS2	R88D-1SN02H-ECT
				1.27 Nm	400 W		R88M-1M40030T-BS2	R88D-1SN04H-ECT
				2.39 Nm	750 W	80 mm	R88M-1M75030T-BS2	R88D-1SN08H-ECT
				3.18 Nm	1 kW	100 mm	R88M-1L1K030T-BS2	R88D-1SN15H-ECT
	4.77 Nm	1.5 kW		R88M-1L1K530T-BS2	R88D-1SN15H-ECT			

Symbol	Specifications					Model	Compatible 1S servo drive			
	Voltage	Encoder and design		Rated torque	Capacity			Flange size		
①	400 V	Absolute encoder (23-bit)	Without brake	2.39 Nm	750 W	100 mm	R88M-1L75030C-S2	R88D-1SN10F-ECT		
				3.18 Nm	1 kW		R88M-1L1K030C-S2	R88D-1SN10F-ECT		
		Straight shaft with key and tap		Without brake	4.77 Nm		1.5 kW	130 mm	R88M-1L1K530C-S2	R88D-1SN15F-ECT
					6.37 Nm		2 kW		R88M-1L2K030C-S2	R88D-1SN20F-ECT
				With brake	9.55 Nm		3 kW		R88M-1L3K030C-S2	R88D-1SN30F-ECT
					12.7 Nm		4 kW		R88M-1L4K030C-S2	R88D-1SN55F-ECT
		With brake	100 mm	15.9 Nm	5 kW	R88M-1L5K030C-S2	R88D-1SN55F-ECT			
				2.39 Nm	750 W	R88M-1L75030C-BS2	R88D-1SN10F-ECT			
				3.18 Nm	1 kW	R88M-1L1K030C-BS2	R88D-1SN10F-ECT			
				4.77 Nm	1.5 kW	R88M-1L1K530C-BS2	R88D-1SN15F-ECT			
			130 mm	6.37 Nm	2 kW	R88M-1L2K030C-BS2	R88D-1SN20F-ECT			
				9.55 Nm	3 kW	R88M-1L3K030C-BS2	R88D-1SN30F-ECT			
				12.7 Nm	4 kW	R88M-1L4K030C-BS2	R88D-1SN55F-ECT			
				15.9 Nm	5 kW	R88M-1L5K030C-BS2	R88D-1SN55F-ECT			

Servo motors 2000 r/min (400 W to 3 kW)

Symbol	Specifications					Model	Compatible 1S servo drive			
	Voltage	Encoder and design		Rated torque	Capacity			Flange size		
①	230 V	Incremental encoder (23-bit)	Without brake	4.77 Nm	1 kW	130 mm	R88M-1M1K020H-S2	R88D-1SN15H-ECT		
				7.16 Nm	1.5 kW		R88M-1M1K520H-S2	R88D-1SN15H-ECT		
		Straight shaft with key and tap	With brake	4.77 Nm	1 kW		R88M-1M1K020H-BS2	R88D-1SN15H-ECT		
				7.16 Nm	1.5 kW		R88M-1M1K520H-BS2	R88D-1SN15H-ECT		
			Absolute encoder (23-bit)	Without brake	4.77 Nm		1 kW	R88M-1M1K020T-S2	R88D-1SN15H-ECT	
					7.16 Nm		1.5 kW	R88M-1M1K520T-S2	R88D-1SN15H-ECT	
		Straight shaft with key and tap	With brake	4.77 Nm	1 kW		R88M-1M1K020T-BS2	R88D-1SN15H-ECT		
				7.16 Nm	1.5 kW		R88M-1M1K520T-BS2	R88D-1SN15H-ECT		
			400 V	Without brake	100 mm		1.91 Nm	400 W	R88M-1M40020C-S2	R88D-1SN06F-ECT
							2.86 Nm	600 W	R88M-1M60020C-S2	R88D-1SN06F-ECT
		130 mm					4.77 Nm	1 kW	R88M-1M1K020C-S2	R88D-1SN10F-ECT
							7.16 Nm	1.5 kW	R88M-1M1K520C-S2	R88D-1SN15F-ECT
	9.55 Nm			2 kW	R88M-1M2K020C-S2	R88D-1SN20F-ECT				
	14.3 Nm			3 kW	R88M-1M3K020C-S2	R88D-1SN30F-ECT				
	With brake	100 mm		1.91 Nm	400 W	R88M-1M40020C-BS2	R88D-1SN06F-ECT			
				2.86 Nm	600 W	R88M-1M60020C-BS2	R88D-1SN06F-ECT			
		130 mm	4.77 Nm	1 kW	R88M-1M1K020C-BS2	R88D-1SN10F-ECT				
			7.16 Nm	1.5 kW	R88M-1M1K520C-BS2	R88D-1SN15F-ECT				
	130 mm	9.55 Nm	2 kW	R88M-1M2K020C-BS2	R88D-1SN20F-ECT					
		14.3 Nm	3 kW	R88M-1M3K020C-BS2	R88D-1SN30F-ECT					



Servo motors 1500 r/min (4 kW to 15 kW)

Symbol	Specifications					Model	Compatible 1S servo drive	
	Voltage	Encoder and design		Rated torque	Capacity			Flange size
①	400 V	Absolute encoder (23-bit)	Without brake	25.5 Nm	4 kW	180 mm	R88M-1M4K015C-S2	R88D-1SN55F-ECT
				35 Nm	5.5 kW		R88M-1M5K515C-S2	R88D-1SN55F-ECT
		47.8 Nm		7.5 kW	R88M-1M7K515C-S2		R88D-1SN75F-ECT	
		220 mm		70 Nm	11 kW		R88M-1M11K015C-S2	R88D-1SN150F-ECT
				95.5 Nm	15 kW		R88M-1M15K015C-S2	R88D-1SN150F-ECT
		With brake	180 mm	25.5 Nm	4 kW	R88M-1M4K015C-BS2	R88D-1SN55F-ECT	
				35 Nm	5.5 kW	R88M-1M5K515C-BS2	R88D-1SN55F-ECT	
				47.8 Nm	7.5 kW	R88M-1M7K515C-BS2	R88D-1SN75F-ECT	
				220 mm	70 Nm	11 kW	R88M-1M11K015C-BS2	R88D-1SN150F-ECT
					95.5 Nm	15 kW	R88M-1M15K015C-BS2	R88D-1SN150F-ECT



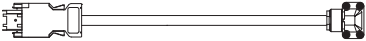

Servo motors 1000 r/min (900 W to 3 kW)

Symbol	Specifications					Model	Compatible 1S servo drive		
	Voltage	Encoder and design		Rated torque	Capacity			Flange size	
①	230 V	Absolute encoder (23-bit)	Without brake	8.59 Nm	900 W	130 mm	R88M-1M90010T-S2	R88D-1SN15H-ECT	
			With brake	8.59 Nm	900 W		R88M-1M90010T-BS2	R88D-1SN15H-ECT	
	400 V	Straight shaft with key and tap	Without brake	180 mm	8.59 Nm	900 W	R88M-1M90010C-S2	R88D-1SN10F-ECT	
					19.1 Nm	2 kW	R88M-1M2K010C-S2	R88D-1SN20F-ECT	
					28.7 Nm	3 kW	R88M-1M3K010C-S2	R88D-1SN30F-ECT	
			With brake	130 mm	8.59 Nm	900 W	R88M-1M90010C-BS2	R88D-1SN10F-ECT	
					180 mm	19.1 Nm	2 kW	R88M-1M2K010C-BS2	R88D-1SN20F-ECT
						28.7 Nm	3 kW	R88M-1M3K010C-BS2	R88D-1SN30F-ECT

Encoder cables

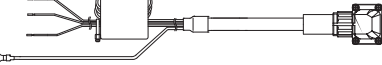
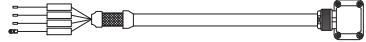
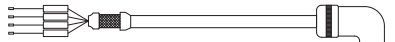
Symbol	Specifications	Model	Appearance	
③	Encoder cable for servo motors R88M-1M05030T-□ R88M-1M(100/200/400/750)30(H/T)-□	1.5 m	R88A-CR1A001-5CF-E	
		3 m	R88A-CR1A003CF-E	
		5 m	R88A-CR1A005CF-E	
		10 m	R88A-CR1A010CF-E	
		15 m	R88A-CR1A015CF-E	
		20 m	R88A-CR1A020CF-E	
	Encoder cable for servo motors R88M-1L(1K0/1K5)30(H/T)-□ R88M-1L(750/1K0/1K5/2K0/3K0/4K0/5K0)30C-□ R88M-1M(1K0/1K5)20(H/T)-□ R88M-1M(400/600/1K0/1K5/2K0/3K0)20C-□ R88M-1M(4K0/5K5/7K5/11K0/15K0)15C-□ R88M-1M90010T-□ R88M-1M(900/2K0/3K0)10C-□	1.5 m	R88A-CR1B001-5NF-E	
		3 m	R88A-CR1B003NF-E	
		5 m	R88A-CR1B005NF-E	
		10 m	R88A-CR1B010NF-E	
		15 m	R88A-CR1B015NF-E	
		20 m	R88A-CR1B020NF-E	

Power cables

Symbol	Specifications	Model	Appearance		
④	For 230 V servo motors R88M-1M05030T-□S2  Note: For servo motors with brake R88M-1M05030T-BS2, the separate brake cable R88A-CA1A□□□BFR is needed.	Without brake	3 m	R88A-CA1A003SFR	
			5 m	R88A-CA1A005SFR	
			10 m	R88A-CA1A010SFR	
			15 m	R88A-CA1A015SFR	
			20 m	R88A-CA1A020SFR	
	For 230 V servo motors R88M-1M(100/200/400/750)30(H/T)-□S2  Note: For servo motors with brake R88M-1M(100/200/400/750)30(H/T)-BS2, the separate brake cable R88A-CA1A□□□BF-E is needed.	Without brake	1.5 m	R88A-CA1A001-5SF-E	
			3 m	R88A-CA1A003SF-E	
			5 m	R88A-CA1A005SF-E	
			10 m	R88A-CA1A010SF-E	
			15 m	R88A-CA1A015SF-E	
			20 m	R88A-CA1A020SF-E	
	For 230 V servo motors R88M-1L(1K0/1K5)30(H/T)-□S2 R88M-1M(1K0/1K5)20(H/T)-□S2 R88M-1M90010T-□S2	Without brake	1.5 m	R88A-CA1C001-5SF-E	
			3 m	R88A-CA1C003SF-E	
			5 m	R88A-CA1C005SF-E	
			10 m	R88A-CA1C010SF-E	
			15 m	R88A-CA1C015SF-E	
			20 m	R88A-CA1C020SF-E	
		With brake	1.5 m	R88A-CA1C001-5BF-E	
			3 m	R88A-CA1C003BF-E	
			5 m	R88A-CA1C005BF-E	
			10 m	R88A-CA1C010BF-E	
			15 m	R88A-CA1C015BF-E	
			20 m	R88A-CA1C020BF-E	
	For 400 V servo motors R88M-1L(750/1K0/1K5/2K0)30C-□S2 R88M-1M(400/600/1K0/1K5/2K0)20C-□S2 R88M-1M90010C-□S2	Without brake	1.5 m	R88A-CA1C001-5SF-E	
			3 m	R88A-CA1C003SF-E	
			5 m	R88A-CA1C005SF-E	
			10 m	R88A-CA1C010SF-E	
			15 m	R88A-CA1C015SF-E	
20 m			R88A-CA1C020SF-E		
With brake		1.5 m	R88A-CA1E001-5BF-E		
		3 m	R88A-CA1E003BF-E		
		5 m	R88A-CA1E005BF-E		
		10 m	R88A-CA1E010BF-E		
		15 m	R88A-CA1E015BF-E		
		20 m	R88A-CA1E020BF-E		

Symbol	Specifications		Model	Appearance		
④	For 400 V servo motors R88M-1L3K030C-□S2 R88M-1M3K020C-□S2 R88M-1M(2K0/3K0)10C-□S2	Without brake	1.5 m	R88A-CA1E001-5SF-E		
			3 m	R88A-CA1E003SF-E		
			5 m	R88A-CA1E005SF-E		
			10 m	R88A-CA1E010SF-E		
			15 m	R88A-CA1E015SF-E		
			20 m	R88A-CA1E020SF-E		
		With brake	1.5 m	R88A-CA1E001-5BF-E		
			3 m	R88A-CA1E003BF-E		
			5 m	R88A-CA1E005BF-E		
			10 m	R88A-CA1E010BF-E		
			15 m	R88A-CA1E015BF-E		
			20 m	R88A-CA1E020BF-E		
		For 400 V servo motors <sup>*1</sup> R88M-1L(4K0/5K0)30C-□S2 R88M-1M(4K0/5K5)15C-□S2	Without brake	3 m	R88A-CA1G003SF	
				5 m	R88A-CA1G005SF	
10 m	R88A-CA1G010SF					
15 m	R88A-CA1G015SF					
With brake	3 m		R88A-CA1G003BF			
	5 m		R88A-CA1G005BF			
	10 m		R88A-CA1G010BF			
	15 m		R88A-CA1G015BF			
	20 m		R88A-CA1G020BF			
	For 400 V servo motors R88M-1M7K515C-□S2		Without brake		3 m	R88A-CA1H003SF
5 m		R88A-CA1H005SF				
10 m		R88A-CA1H010SF				
15 m		R88A-CA1H015SF				
With brake		3 m	R88A-CA1H003BF			
		5 m	R88A-CA1H005BF			
		10 m	R88A-CA1H010BF			
		15 m	R88A-CA1H015BF			
		20 m	R88A-CA1H020BF			
		For 400 V servo motors R88M-1M(11K0/15K0)15C-□S2	Without brake		3 m	R88A-CA1J003SF
5 m	R88A-CA1J005SF					
10 m	R88A-CA1J010SF					
15 m	R88A-CA1J015SF					
With brake	3 m		R88A-CA1J003BF			
	5 m		R88A-CA1J005BF			
	10 m		R88A-CA1J010BF			
	15 m		R88A-CA1J015BF			
	20 m		R88A-CA1J020BF			

\*1 Refer to the "Using R88A-CA1G power cables" technical note when using multiple cables in the same duct.

**Extension power cables (for 400 V, 4 kW to 15 kW servo motors)**

Symbol	Specifications		Model	Appearance
④	R88M-1L(4K0/5K0)30C-□S2 R88M-1M(4K0/5K5)15C-□S2	10 m	R88A-CA1GE10BF	
		20 m	R88A-CA1GE20BF	
	R88M-1M7K515C-□S2	10 m	R88A-CA1HE10BF	
		20 m	R88A-CA1HE20BF	
	R88M-1M(11K0/15K0)15C-□S2	10 m	R88A-CA1JE10BF	
		20 m	R88A-CA1JE20BF	

### Combinations of Motor power cables and Extension power cables

The table below lists the combinations of cables that can be used to extend the motor power cable for a servomotor of 4 kW or more to more than 20 m.

Use the motor power cable and extension power cable in a specified combination. Not doing so may cause fire, equipment damage, or operation failure.

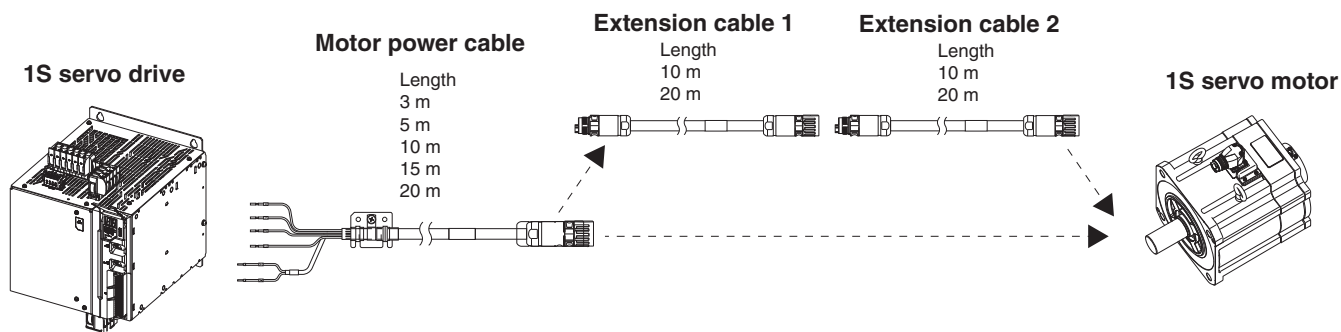

Length				Combination
Total	Motor power cable	Extension cable 1	Extension cable 2	
3	3	-	-	Motor power cable only
5	5	-	-	Motor power cable only
10	10	-	-	Motor power cable only
15	15	-	-	Motor power cable only
20	20	-	-	Motor power cable only
30	20	10	-	Motor power cable + extension cable 1
40	20	20	-	Motor power cable + extension cable 1
50	20	10	20	Motor power cable + extension cable 1 + extension cable 2 <sup>*1</sup>

\*1 A 20 m extension cable 1 and a 10 m extension cable 2 can also be used.

### Brake cables (for 230 V, 50 W to 750 W servo motors)

Symbol	Specifications	Model	Appearance	
⑤	Brake cable only For 230 V servo motors with brake R88M-1M05030T-BS2	3 m	R88A-CA1A003BFR	
		5 m	R88A-CA1A005BFR	
		10 m	R88A-CA1A010BFR	
		15 m	R88A-CA1A015BFR	
		20 m	R88A-CA1A020BFR	
	Brake cable only For 230 V servo motors with brake R88M-1M(100/200/400/750)30(H/T)-BS2	1.5 m	R88A-CA1A001-5BF-E	
		3 m	R88A-CA1A003BF-E	
		5 m	R88A-CA1A005BF-E	
		10 m	R88A-CA1A010BF-E	
		15 m	R88A-CA1A015BF-E	
		20 m	R88A-CA1A020BF-E	

## Connectors for encoder, power and brake cables

Specifications		Applicable servo motor	Model
Connectors for encoder cables	Drive side (CN2)	All models	R88A-CN101R
	Motor side	R88M-1M05030T-□ R88M-1M(100/200/400/750)30(H/T)-□ R88M-1L(1K0/1K5)30(H/T)-□ R88M-1L(750/1K0/1K5/2K0/3K0/4K0/5K0)30C-□ R88M-1M(1K0/1K5)20(H/T)-□ R88M-1M(400/600/1K0/1K5/2K0/3K0)20C-□ R88M-1M(4K0/5K5/7K5/11K0/15K0)15C-□ R88M-1M90010T-□ R88M-1M(900/2K0/3K0)10C-□	R88A-CNK02R  R88A-CN104R
Connectors for power cables	Motor side	R88M-1M(100/200/400/750)30(H/T)-_S2	R88A-CN111A
		R88M-1L(1K0/1K5)30(H/T)-S2 R88M-1M(1K0/1K5)20(H/T)-S2 R88M-1M90010T-S2 R88M-1L(750/1K0/1K5/2K0)30C-S2 R88M-1M(400/600/1K0/1K5/2K0)20C-S2 R88M-1M90010C-S2	MS3108E20-4S
		R88M-1L(1K0/1K5)30(H/T)-BS2 R88M-1M(1K0/1K5)20(H/T)-BS2 R88M-1M90010T-BS2	MS3108E20-18S
		R88M-1L3K030C-S2 R88M-1M3K020C-S2 R88M-1M(2K0/3K0)10C-S2	MS3108E22-22S
		R88M-1L(750/1K0/1K5/2K0/3K0)30C-BS2 R88M-1M(400/600/1K0/1K5/2K0/3K0)20C-BS2 R88M-1M(900/2K0/3K0)10C-BS2	MS3108E24-11S
		R88M-1M(100/200/400/750)30(H/T)-BS2	R88A-CN111B
Connectors for brake cables	Motor side	R88M-1M(100/200/400/750)30(H/T)-BS2	R88A-CN111B

## Cable shield clamp (spare parts)

Applicable 1S power cable	Model
230 V, 100 W to 750 W models	R88A-SC011S-E
230 V, 1.5 kW model 400 V, 600 W to 3 kW models	R88A-SC021S-E
400 V, 5.5 kW to 15 kW models	R88A-SC10CA-PE

ALL DIMENSIONS SHOWN ARE IN MILLIMETERS.

To convert millimeters into inches, multiply by 0.03937. To convert grams into ounces, multiply by 0.03527.



# SCATTERGOOD & JOHNSON LTD

ELECTRICAL ENGINEERING & FLUID CONTROL DISTRIBUTORS

Est.1899

At Scattergood & Johnson Ltd, we pride ourselves on being a technical distributor to specialist industries.

Working with a range of quality product suppliers across a number of specialist markets, we are not your average 'box shifter' - we are your technical and supply chain partner.

We fully support every product we sell - for free! Our internal team and external sales engineers can answer any product or application question, no matter the complexity.

Backing up this technical ability is a range of 50,000+ products available from stock for nationwide next day delivery (same day if required!), or you can collect what you need from any of our trade counters around the UK.

Select your specialist interest below to learn more about how we can help.



Online, In Branch and On the Road - Scattergood & Johnson Ltd, there when you need us.

# [www.scatts.co.uk](http://www.scatts.co.uk)