

## Ultrasonic sensor UC10000-F260-IE8R2

- Large sensing range
- Adjustable Bracket
- Programmable by means of Interface (see accessories) and SONPROG
- Analog output 4 ... 20 mA
- 2 switch outputs
- Synchronization options
- Temperature compensation

Single head system



### Function

This ultrasonic sensor is a contactless distance sensor based on the echo run time principle. It is suitable for the detection of solid, liquid or powder sound-reflecting objects. The unique sensor design allows easy movement of the direction of sound radiation in all spatial directions by up to 10° without additional an additional assembly device.

### Dimensions

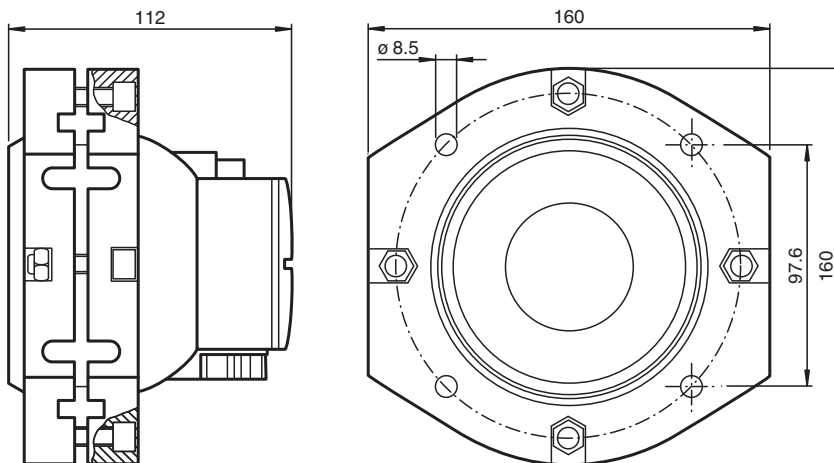

### Technical Data

#### General specifications

Sensing range	800 ... 10000 mm
Adjustment range	800 ... 10000 mm
Dead band	0 ... 800 mm
Standard target plate	100 mm x 100 mm

Release date: 2021-02-05 Date of issue: 2021-02-05 Filename: 250790\_eng.pdf

Refer to "General Notes Relating to Pepperl+Fuchs Product Information".

Pepperl+Fuchs Group  
www.pepperl-fuchs.com

USA: +1 330 486 0001  
fa-info@us.pepperl-fuchs.com

Germany: +49 621 776 1111  
fa-info@de.pepperl-fuchs.com

Singapore: +65 6779 9091  
fa-info@sg.pepperl-fuchs.com

**PF** PEPPERL+FUCHS

## Technical Data

Transducer frequency		approx. 60 kHz
<b>Nominal ratings</b>		
Time delay before availability	$t_v$	280 ms
<b>Limit data</b>		
Permissible cable length		max. 300 m
<b>Indicators/operating means</b>		
LED yellow		solid: switching state switch output flashing: misadjustment
<b>Electrical specifications</b>		
Rated operating voltage	$U_e$	24 V DC
Operating voltage	$U_B$	15 ... 30 V (including ripple) In supply voltage interval 15 ... 20 V sensitivity reduced to 20% ... 0%
Ripple		$\leq 10$ %
No-load supply current	$I_0$	$\leq 75$ mA
<b>Input/Output</b>		
Input/output type		1 synchronization connection, bidirectional
0 Level		$\leq 3$ V
1 Level		15 ... 30 V
Input impedance		typ. 0.9 k $\Omega$
Number of sensors		max. 10
<b>Switching output</b>		
Output type		2 switch outputs PNP, NO
Repeat accuracy	R	$\pm 15$ mm
Operating current	$I_L$	300 mA , short-circuit/overload protected
Voltage drop		$\leq 3$ V
Switch-on delay		800 ms
<b>Analog output</b>		
Output type		1 current output 4 ... 20 mA rising ramp
Default setting		800 ... 10000 mm
Linearity error		$\leq 1.5$ %
Load resistor		$\leq 300$ $\Omega$
<b>Compliance with standards and directives</b>		
Standard conformity		
Standards		EN 60947-5-2:2007+A1:2012 IEC 60947-5-2:2007 + A1:2012 EN 60947-5-7:2003 IEC 60947-5-7:2003
<b>Approvals and certificates</b>		
UL approval		cULus Listed, General Purpose
CSA approval		cCSAus Listed, General Purpose
CCC approval		CCC approval / marking not required for products rated $\leq 36$ V
<b>Ambient conditions</b>		
Ambient temperature		-25 ... 70 °C (-13 ... 158 °F)
Storage temperature		-40 ... 85 °C (-40 ... 185 °F)
Shock resistance		30 g , 11 ms period
Vibration resistance		10 ... 55 Hz , Amplitude $\pm 1$ mm
<b>Mechanical specifications</b>		
Connection type		screw terminals , PG 13.5 cable gland
Degree of protection		IP65
Material		
Housing		UP 1225 SF/R8
Transducer		epoxy resin/hollow glass sphere mixture; polyurethane foam
Installation position		any position
Mass		1800 g

Release date: 2021-02-05 Date of issue: 2021-02-05 Filename: 250790\_eng.pdf

Refer to "General Notes Relating to Pepperl+Fuchs Product Information".

Pepperl+Fuchs Group  
www.pepperl-fuchs.comUSA: +1 330 486 0001  
fa-info@us.pepperl-fuchs.comGermany: +49 621 776 1111  
fa-info@de.pepperl-fuchs.comSingapore: +65 6779 9091  
fa-info@sg.pepperl-fuchs.com

**PEPPERL+FUCHS**

**Connection**

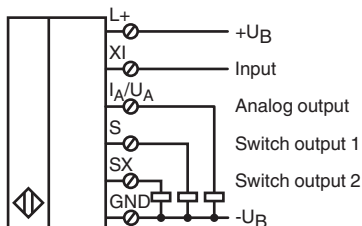

**Characteristic Curve**

**Characteristic response curve**

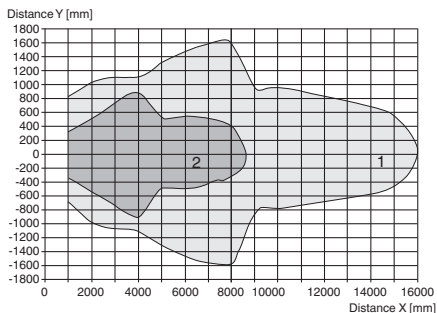

Curve 1: flat surface 100 mm x 100 mm  
Curve 2: round bar, Ø 25 mm

**Characteristic Curve**

**Area definitions**

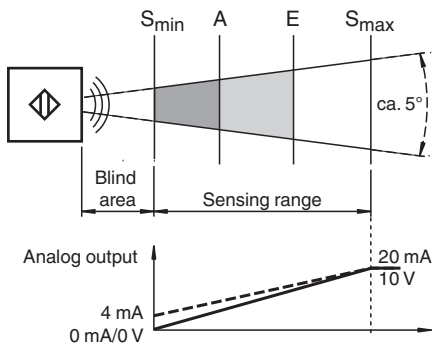

Release date: 2021-02-05 Date of issue: 2021-02-05 Filename: 250790\_eng.pdf

**Accessories**

	<b>DA5-IU-C</b>	Digital display unit
	<b>3RX4000-PF</b>	PC interface
	<b>V15S-G-2M-PVC</b>	Male cordset single-ended M12 straight A-coded, 5-pin, PVC cable grey
	<b>V1-M20-80</b>	Receptacles, M12/M20; plastic version

Refer to "General Notes Relating to Pepperl+Fuchs Product Information".

## Additional Information



### Danger!

This product must not be used in applications in which the safety of persons depends on the device function. This product is not a safety component in accordance with the EU Machinery Directive.

### Assembly and connection

When installing the sensor, make sure that the space filled by the sound cone is free from interfering objects. Objects in the blind zone cause false signals. Implement suitable measures to ensure that objects cannot enter the blind zone.

The electrical connection is made via screw terminals. The connections are protected against reverse polarity, short circuits and overloads. Shielded cables are recommended if there is electrical interference.

### Setting

The detection range limits  $S_{min}$  and  $S_{max}$  are fixed (see Technical data). Within these limits, the switch points A and E are set using a potentiometer. Switch point A must be smaller than switch point E. If this is not the case, the LED flashes and correct switching is not possible.

### Parameterisation via SONPROG

The following parameters can be changed via the SONPROG parameterisation software:

- Measuring range limits  $S_{min}$  and  $S_{max}$
- Switch-on and switch-off points E and A
- Blind zone
- Averaging
- Analogue limits
- Analogue characteristic, rising/falling

### Operation

Within the detection range, which is restricted by the detection range limits  $S_{min}$  and  $S_{max}$ , the object distance is detected. Objects with an even, smooth surface can have a maximum inclination of  $3^\circ$  to the direction of sound propagation. With rough, uneven surfaces the angular deviation can be bigger. The actual value depends significantly on the object finish and should be obtained experimentally if necessary.

### Behaviour of the switch outputs:

- If the object is at a distance  $> E$ , both switch outputs are in standby mode.
- If the object is between E and A, switch output S is activated and switch output SX is in standby mode.
- If the object is at a distance  $< A$ , switch output SX is activated and switch output S is in standby mode.

### Behaviour of the analogue output:

The object distance between the detection range limits ( $S_{min}$ ,  $S_{max}$ ) are displayed in the form of an analogue output signal at the analogue output. The analogue output delivers its minimum value at distance  $S_{min}$  and its maximum value at distance  $S_{max}$ . The characteristic between the two measuring range limits is linear. Outside of  $S_{max}$  the analogue output retains its maximum value.

### Display:

The sensor has an LED. It lights up continuously when the output terminal S is carrying a voltage. It flashes when switch points A and E are set incorrectly (see Setting).

### Function input XI

The sensor is placed in standby mode by connecting a low level at the function input XI (blocked release). The sensors then performs no measurements. The switch outputs retain the most recent status. As soon as function input XI is disconnected from the low level or a high level is connected (release), the sensor resumes its normal function after the release period has expired.

The function input XI can be used during operation for the synchronisation of multiple sensors in the event of mutual interference. The following synchronisation modes are possible:

- Triggering of each individual sensor with a separate control signal, e.g. by a PLC (external synchronisation).
- Connection of the function inputs XI of all sensors and joint triggering with an external control signal, e.g. by a PLC (external synchronisation, common-mode operation).
- Connection of the function inputs XI of all sensors and without triggering with an external signal (internal synchronisation, multiplex mode).

### Maintenance

The ultrasonic sensor is maintenance-free. However, the converter surface must not be wet, damaged, painted or covered with material deposits..

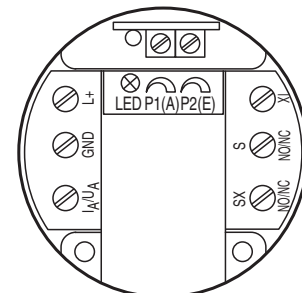

## Connection Assignment

### Connecting the PC interface 3RX4000-PF to use SONPROG

This sensor can be parameterised using SONPROG for an optimum adaptation to the application. Therefore the sensor provides communication with the 3RX4000-PF PC interface. To connect to the 3RX4000-PF PC interface a 4- or 5-pin M12 male cable connector is required. We recommend e. g. an adapter V1-M20-80 or a cable connector V15S-G-2M-PVC.

Please connect the wires to the sensors terminals as shown, below.

## Ultrasonic sensor

UC10000-F260-IE8R2

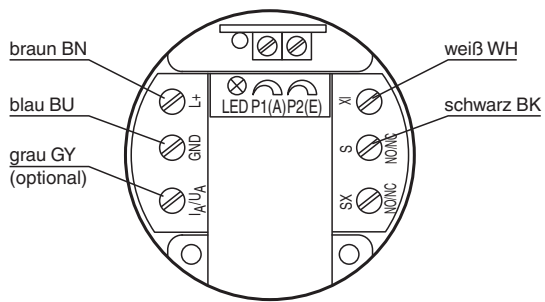

The terminals  $I_A/U_A$  (analog output) and SX (2<sup>nd</sup> switching output) are not needed for programming.



# SCATTERGOOD & JOHNSON LTD

ELECTRICAL ENGINEERING & FLUID CONTROL DISTRIBUTORS

Est.1899

At Scattergood & Johnson Ltd, we pride ourselves on being a technical distributor to specialist industries.

Working with a range of quality product suppliers across a number of specialist markets, we are not your average 'box shifter' - we are your technical and supply chain partner.

We fully support every product we sell - for free! Our internal team and external sales engineers can answer any product or application question, no matter the complexity.

Backing up this technical ability is a range of 50,000+ products available from stock for nationwide next day delivery (same day if required!), or you can collect what you need from any of our trade counters around the UK.

Select your specialist interest below to learn more about how we can help.



Online, In Branch and On the Road - Scattergood & Johnson Ltd, there when you need us.

# [www.scatts.co.uk](http://www.scatts.co.uk)