

# PLIO06, PLIO06-CDS MULTIFUNCTION DIGITAL I/O MODULE

- PLIO06:**
- 8 digital inputs
  - 6 digital outputs
  - 1 relay output

The PLIO06 is a compact multifunction I/O module. It has been designed as an optional plug-in for the eTOP Series 500 HMI products. The PLIO06 provides typical industrial isolated digital inputs and outputs.

The PLIO06-CDS has installed CODESYS™ softlogic system.

## Specifications DIGITAL INPUTS

Description	Specifications
Input channels	8 digital optoisolated (industrial standard) source active high (+24VDC) inputs. All inputs are internally connected to 0VDC of PLIO06 power supply.
Input voltage range	12÷30VDC (min 3mA), 35VDC max for 500 ms
ON-state voltage/current	12÷30VDC (min 3mA) 6mA @ 24VDC, 9mA @ 30VDC
OFF-state voltage/current	6VDC max, 1mA
Input impedance	3,3K Ohm
Input filter delay max	50 µs
Debounce filter	Programmable 0.1ms to 20ms
Isolation	1500 Vrms
Connector type	Ommimate Range header/plugs 3.5mm-10 contacts (two piece terminal blocks) SL-SMT 3.5/180F Box + BLZF 3.5/180F

## DIGITAL OUTPUTS

Description	Specifications
Output channels	6 digital source type optoisolated outputs with feedback of output driver fault status.
Output voltage	12÷30VDC
Output current	0.5A
Output delay time	150 µs max
Output protection	Overcurrent and overtemperature protected driver
Isolation	1500 Vrms
Connector type	Ommimate Range header/plugs 3.5mm-10 contacts (two piece terminal blocks) SL-SMT 3.5/180F Box + BLZF 3.5/180F

## RELAY OUTPUT

Description	Specifications
Output channels type	Relay single contact (norm open)
Load	Resistive load
Rated load	1A at 30Vrms
Max switching voltage	42.4Vac (30Vrms); 60Vdc
Max switching current	1A
Isolation	1500 Vrms

## ENVIRONMENTAL CONDITIONS

Description	Specifications
Operating temperature	0÷50 °C
Storage temperature	-20÷70 °C
Operating humidity	5÷85% relative humidity, non condensing
Protection class	IP20

1

MANPLIO06-001 V.1.02

2

MANPLIO06-001 V.1.02

## Dimensions

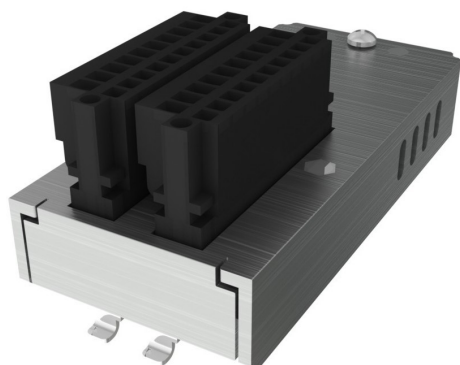
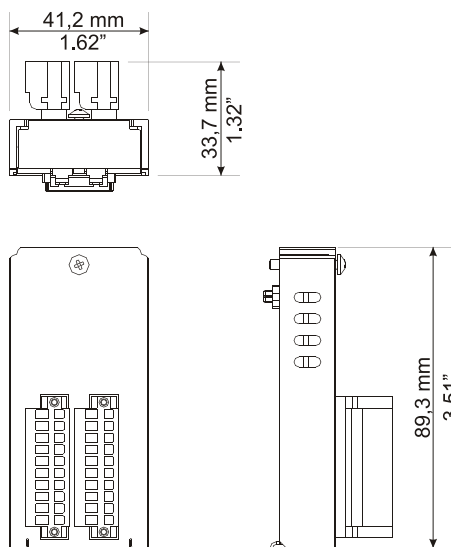

## Pin assignment/connectors view

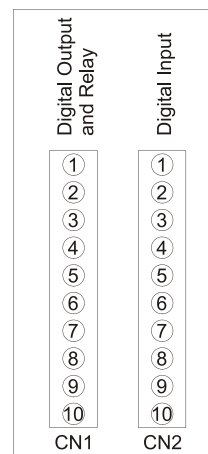

CN1 (Dig. Out.)      CN2 (Dig. In.)

- |           |        |
|-----------|--------|
| 1 +24V    | 1 +24V |
| 2 Relay 1 | 2 In 1 |
| 3 Relay 2 | 3 In 2 |
| 4 Out 1   | 4 In 3 |
| 5 Out 2   | 5 In 4 |
| 6 Out 3   | 6 In 5 |
| 7 Out 4   | 7 In 6 |
| 8 Out 5   | 8 In 7 |
| 9 Out 6   | 9 In 8 |
| 10 GND    | 10 GND |

3

MANPLIO06-001 V.1.02

4

MANPLIO06-001 V.1.02

**Wiring examples (standard digital inputs and outputs)**

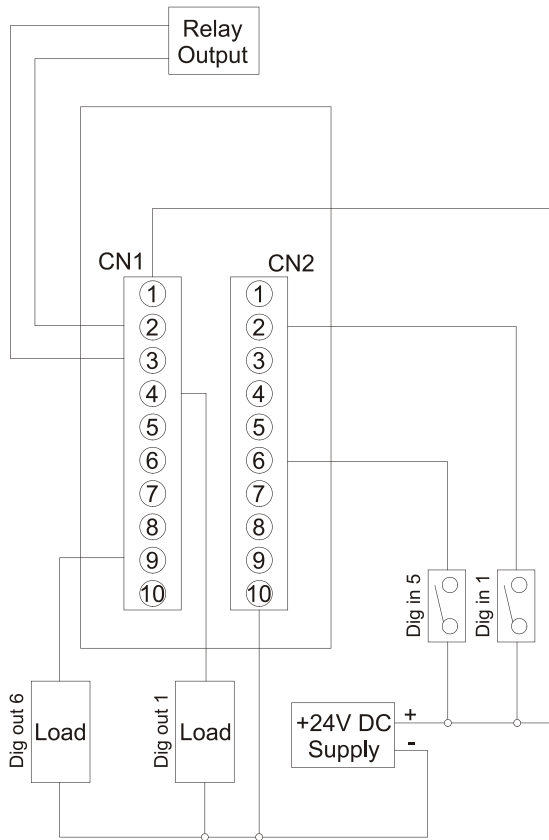

**Note on wiring**

The cables must be no longer than 30m.

5

MANPLIO06-001 V.1.02

6

MANPLIO06-001 V.1.02

The products have been designed for use on Exor products with expansion slot for plugin module for use in an industrial environment in compliance with the 2014/30/EU directive

The products have been designed in compliance with:

- |              |                  |
|--------------|------------------|
| EN 61000-6-4 | EN 55011 Class A |
| EN 61000-6-2 | EN 61000-4-2     |
|              | EN 61000-4-3     |
|              | EN 61000-4-4     |
|              | EN 61000-4-5     |
|              | EN 61000-4-6     |
|              | EN 61000-4-8     |
|              | EN 60945         |

The installation of these devices into the residential, commercial and light-industrial environments is allowed only in the case that special measures are taken in order to get the conformity to IEC-61000-6.3.



This device cannot be disposed of as a domestic waste but according to WEEE European Directive 2012/19/EU



7

MANPLIO06-001 V.1.02

8



**SCATTERGOOD  
& JOHNSON LTD**  
ELECTRICAL ENGINEERING & FLUID CONTROL DISTRIBUTORS

Est.1899

At Scattergood & Johnson Ltd, we pride ourselves on being a technical distributor to specialist industries.

Working with a range of quality product manufacturers across a number of specialist markets, we are not your average 'box shifter' - we are your technical and supply chain partner.

We fully support every product we sell - for free! Our internal team and external sales engineers can answer any product or application question, no matter the complexity.

Backing up this technical ability is a range of 50,000+ products available from stock for nationwide next day delivery (same day if required!), or you can collect what you need from any of our trade counters around the UK.

Select your specialist interest below to learn more about how we can help.



Online, In Branch and On the Road - Scattergood & Johnson Ltd, there when you need us.

**[www.scatts.co.uk](http://www.scatts.co.uk)**