



LevelMaster - Capacitive Sensors Series 26

Model G 1/2"

- For level control of conductive and/or viscous liquids or pastes, for instance oil, water, ketchup or honey.
- Ideal for level control in the Food Industry or Pharmaceutical Industry
- Housing material: Stainless steel (VA)
- Adjustment of the sensitivity with ETW- Function (EasyTeach by wire)
- With flange connector M 12 x 1
- Welding sockets and Varivent adapter available for EHEDG conform mounting.



Technical data	Non-flush mountable
Sensitivity	Dielectric constant $\epsilon_r > 1.25$
Electrical version	3-pin DC
Output function	Normally open
Factory setting	Water
Typ PNP	KS-801-26/84-S-G1/2-PEEK/VAb-Y3-ETW-HP
Art. No.	KA 1437
Connection diagram No.	See below
Operating voltage (U_b)	12.5...35 V DC
Voltage drop max. (U_d)	≤ 2.0 V
Operating current (I_e)	0...250 mA
No-load current (I_o)	Typ. < 30 mA
Frequency of operating cycles max.	1 Hz
Permitted ambient temperature	-10...+70 °C / CIP 121 °C (zero-current)
Permitted product temperature	0...+100 °C
LED-display	Green / orange
Protective circuit	Built-in
Degree of protection IEC 60529	IP 67, IP 69K
Norm	EN 60947-5-2*
Connection	Connector M 12 x 1
Operating pressure	Max. 10 bar
Housing material	Stainless steel VA No. 1.4305 / AISI 303
Material active surface	PEEK (FDA 21 CFR 177.2415)
Material lid	-
Accessories (not supplied with the sensor): Varivent Adapter art.No. 196395, Welding Socket art.No. 196394 and matching connectors please see our selection of accessories.	

Capacitive Sensors of the 26 series with hemispherical active surface for level control of products with a dielectric constant ϵ_r from 1,25. Products such as:

- Liquids, like, juice, wine, oil, chemicals or pharmaceutical solutions and much more.

Highlights:

- EHEDG conform
- Measurement is independent of the mounting position
- Permitted pressure on the active area: 10 bar

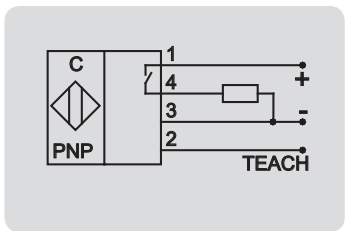

All specifications are subject to change without notice. (12/2016)

*Where applicable

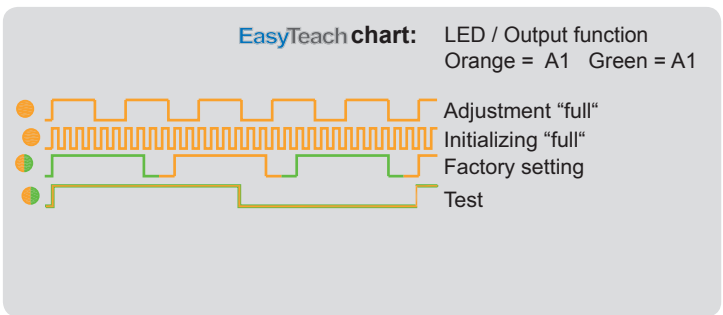
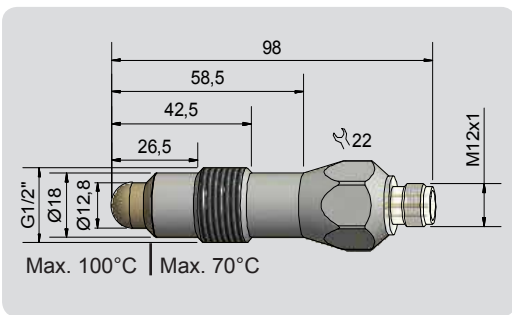

Made in Germany

LevelMaster

EXtra
Smart

This capacitive sensor is designed for the level control of liquid or viscous products, which can be conductive and/or viscous and sticky.

Materials like ketchup, mayonnaise, yoghurt, syrups, pastes, or liquids with salt or acids will be reliably detected with the LevelMaster.



It could not be easier.

The user mounts the sensor, makes the electrical connection and the adjustment by means of the teach wire and the sensor is ready for use.

No additional teach equipment necessary.

Optical guidance during the teach process with the aid of a 2-colour LED:

• standby • teach process • switching state

The modern micro controller controlled temperature compensation provides for reliable level control with applications where there are variations in the ambient temperatures.

The sensor body is made of stainless steel Material Nr. 1.4305 (AISI 303).

When the sensor is mounted with our adapters: welding socket or the process adapter Varivent N DN 50 a hygienic, EHEDG conforming process connection will be achieved.

Directive (EC) 1935/2004

The traceability of the used plastic material PEEK according to the directive (EC) 1935/2004 is confirmed by RECHNER with a conformity declaration, that is provided on the website as download document under certificates.



All specifications are subject to change without notice. (12/2016)



**SCATTERGOOD
& JOHNSON LTD**
ELECTRICAL ENGINEERING & FLUID CONTROL DISTRIBUTORS

Est.1899

At Scattergood & Johnson Ltd, we pride ourselves on being a technical distributor to specialist industries.

Working with a range of quality product manufacturers across a number of specialist markets, we are not your average 'box shifter' - we are your technical and supply chain partner.

We fully support every product we sell - for free! Our internal team and external sales engineers can answer any product or application question, no matter the complexity.

Backing up this technical ability is a range of 50,000+ products available from stock for nationwide next day delivery (same day if required!), or you can collect what you need from any of our trade counters around the UK.

Select your specialist interest below to learn more about how we can help.



Online, In Branch and On the Road - Scattergood & Johnson Ltd, there when you need us.

www.scatts.co.uk