

INSTALLATION MANUAL

Z-8NTC

RS485 Modbus RTU Module
with 8 NTC Inputs

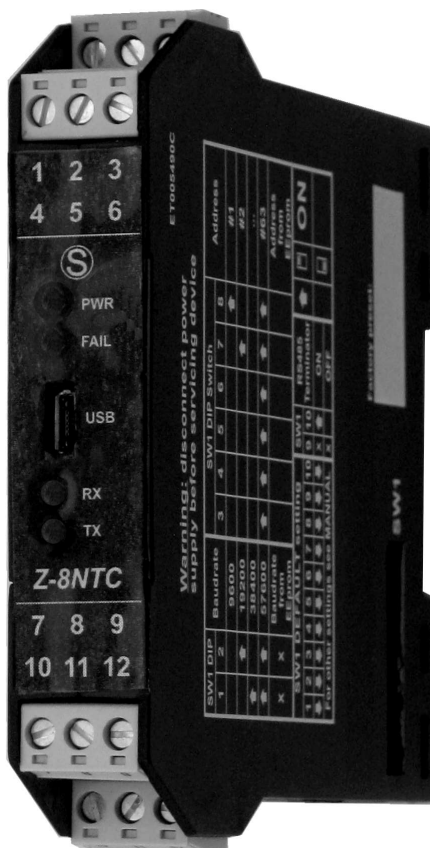

SENECA s.r.l.
Headquarters: Via Austria, 26 – 35127 – PADOVA – ITALY
Phone +39.049.8705355 - 8705359 - Fax +39.049.8706287
 Manuals and configuration software are available at website:
www.seneca.it/products/z-8ntc

This document is property of SENECA Srl. Duplication and reproduction are forbidden, if not authorized. Contents of the present documentation refers to products and technologies described in it. This informations may be modified or integrated for technical and / or commercial requirements.

MODULE DESCRIPTION

Z-8NTC is a digital converter for: Resistors, NTC and PTC, with eight measurement channels, insulated up to 1.5 kV from power supply and from serial communication line.

The module is characterized by a three-point overall insulation.

GENERAL CHARACTERISTICS

- 16-bit A/D conversion on three adjustable scales 100 Ω – 10 k Ω , 1 k Ω – 100 k Ω , 5 k Ω – 500 k Ω .
- 0.5% accuracy on resistance value.
- Measurement available in the following sizes: Resistance (Ω) or Temperature ($^{\circ}\text{C}$, $^{\circ}\text{F}$, $^{\circ}\text{K}$) on Integer 32-bit and Floating point 32-bit, direct or swapped.
- Conversion From temperature to resistance with Steinhart-Hart equation.
- Each channel can be individually enabled and configured.
- Programmable filter for reading stabilization.
- Conversion time: 500 ms for all the channels; Rejection 50/60 Hz
- Linearization through configuration software for sensors: NTC, BALCO, COSTER, KTY etc.
- Easy power supply and serial bus wiring by means of the Seneca Z-BUS housed in the DIN rail.
- Removable screw terminals for section Max. 2.5 mm² cable.
- DIP switches configurable or software configurable communication parameters.
- RS485 Serial communication with MODBUS-RTU protocol.
- Frontal USB Port for MODBUS-RTU configuration and communication.

MODULE LAYOUT

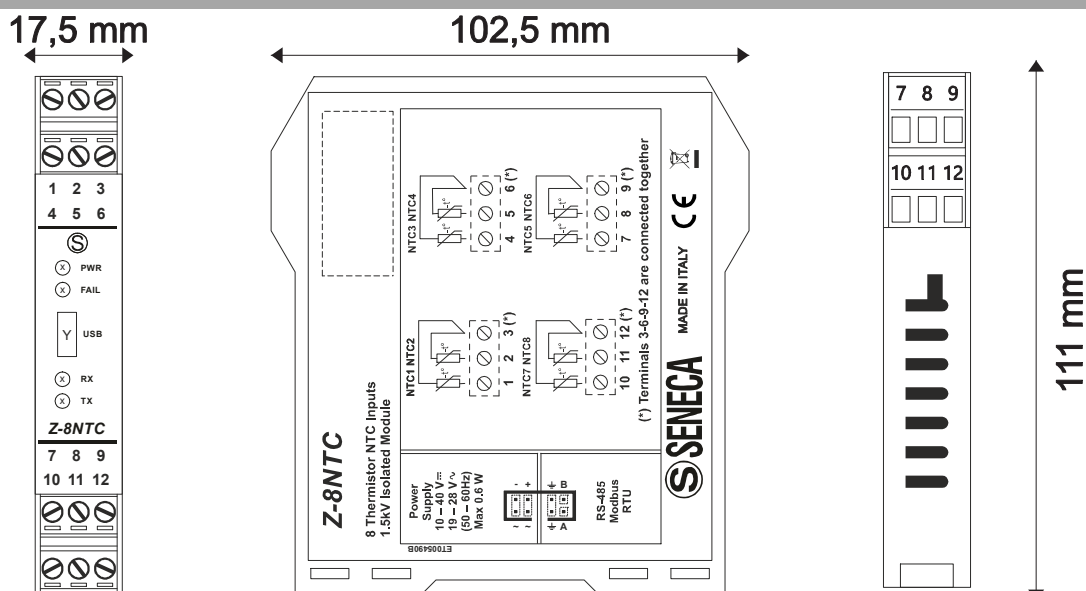

Dimensions (L×H×W)	17,5 x 102,5 x 111 mm
Weight	140 g.
Case	Material PA6, Black color.

LED SIGNALLING ON FRONT PANEL

LED	State	LEDs Meaning
PWR (Green)	On	Power supply presence
	Off	The device is powered off
FAIL (Yellow)	Blinking On	Error settings Fault or Failure
RX (Red)	Blinking On	Received data from RS485 Verify the connection
TX (Red)	Blinking On	Transmitted data to RS485 Verify the connection



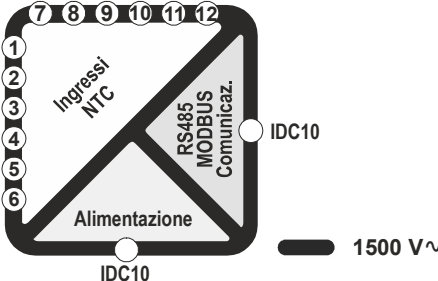



TECHNICAL SPECIFICATIONS

STANDARDS	EN61000-6-4 Electromagnetic emission, industrial environment EN61000-6-2 Electromagnetic immunity, industrial environment EN61010-1 Safety
INSULATION	
ENVIRONMENTAL COND.	<i>Temperature</i> -20 – +70°C <i>Humidity</i> 30% – 90% a 40°C not condensing <i>Altitude</i> Up to 2000 m a.s.l. <i>Storage temperature</i> -20 – + 85°C <i>Protection degree</i> IP20
MOUNTING	IEC EN60715 DIN Rail
CONNECTIONS	Removable 3-way screw terminals, 5,08 mm pitch Rear IDC10 connector for CEI EN60715 rail Micro USB frontal panel connector.

TECHNICAL SPECIFICATIONS

POWER SUPPLY		
<i>Tension</i>	10 – 40 V $\overline{=}$ o 19 – 28 V \sim 50 – 60 Hz	
<i>Power absorbed</i>	Max. 0.6W	
NTC INPUTS	Generic NTC with user-definable curve.	
<i>Number of channels</i>	8	
<i>Measurement range</i>	Rated values	Range of measurements
	1k Ω	from 100 Ω to 10k Ω
	10k Ω	from 1k Ω to 100k Ω
	50k Ω	from 5k Ω to 500k Ω
<i>Resolution</i>	16 bit, min. 0.02 % of the value at the scale limits	
<i>Accuracy</i>	0.5 %	
<i>Stability</i>	100 ppm	

PRELIMINARY WARNINGS

	Before performing any operation is mandatory to read the full contents of this manual. The module may only be used by qualified and skilled technicians in the field of electric installation. Specific documentation is available for download at website: www.seneca.it/products/z-8ntc .
	Only the Manufacturer is authorized to repair the module or to replace damaged parts. The product is susceptible to electrostatic discharge, take appropriate countermeasures during any operation.
	No warranty is granted in connection with faults resulting from improper use, from modifications or repairs carried out by Manufacturer-unauthorized personnel on the device, or if the content of this user Manual is not followed.
	It is forbidden to place anything that could obstruct the ventilation slits. It is forbidden to install the module near heat sources.
	Severe operating conditions: -Powersupply > 30 V $\overline{=}$, Powersupply > 26 V \sim and the module power the input sensor. Separate the module at least 5 mm away from the other devices installed side by side if the module operate with: - The operating temperature > 40°C and one of the severe operating condition exists. - The operating temperature > 35°C and two of the severe operating conditions exist.
	Disposal of electrical & electronic equipment (applicable throughout the EU and other countries with separate collection programs). The symbol found on this product or on its packaging, indicates that this product it must be handed over to an applicable collection point for the recycling of electrical and electronic equipments.

MODBUS CONNECTION STANDARDS

- 1) Install the modules on the DIN rail (max 120).
 - 2) Connect the remote modules using cables of proper length.
- On the table the following data about the cables length are provided:

- Bus Length: Modbus network maximum length as a function of the Baud rate.
It is the length of the cables which connect the two bus terminators modules (see Scheme 1).
- Drop Length: maximum length of a drop line (see Scheme 1).

Scheme 1

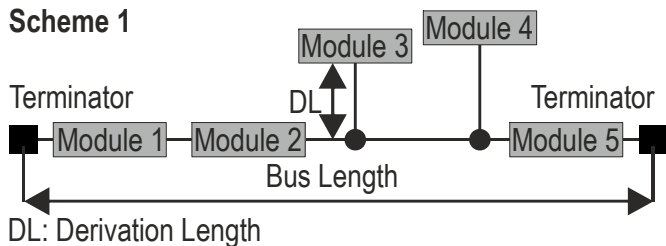

• MODBUS Scheme 1

Bus length	Derivation Length	Baudrate
1200 m	2 m	115kbps

In order to obtain maximum performances it's recommended to use a specific shielded cable, as an example BELDEN 9841.

INSTALLATION RULES

In order to ensure optimum performance and a longest working life, the module(s) must be provided with adequate ventilation and no raceways or other objects that obstruct the ventilation slots.

Never install the modules near heat sources.

We recommend installation in the lower part of the control panel.

INSTALLATION ON AND REMOVAL FROM IEC EN 60715 DIN RAIL

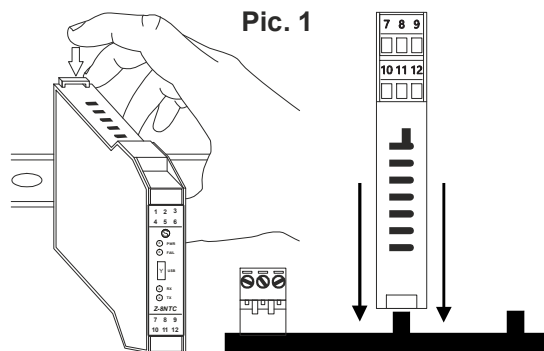

Pic. 1

Insertion on the IEC EN 60715 DIN rail:

- 1) Move the two hooks on the back of the module outwards as illustrated in **Pic.2**.
- 2) Insert the module rear IDC10 connector into a free slot of DIN rail accessory as you can see in **Pic.1**. (the insertion is one way only because the connectors are polarized).
- 3) To secure the module to the IEC EN 60715 DIN rail, tighten the two hooks on the side of the IDC10 rear connector as shown in **Pic.1**.

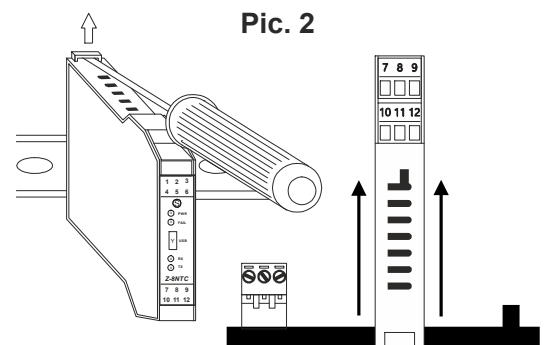

Pic. 2

Removal from IEC EN 60715 DIN rail:

As shown in **Pic.2**:

- 1) Move outwards the two hooks on the side of the module, with the help of a screwdriver.
- 2) Extract the module from the IEC EN 60715 DIN rail.

USE OF Z-PC-DINAL ACCESSORY

Don't turn upside down the module and **don't force the insertion** of the IDC10 connector into the Z-PC-DIN bus. The IDC10 connector located on the rear of the module will be inserted on a free slot of Z-PC-DIN accessory. In the figure you can see the meaning of the various pins of the rear IDC10 connector if you want to provide the signals directly through this connector. The pictures **Pic.3** and **Pic.4** show how to connect powersupply and RS485 COM1 port to the rear IDC10 connector.

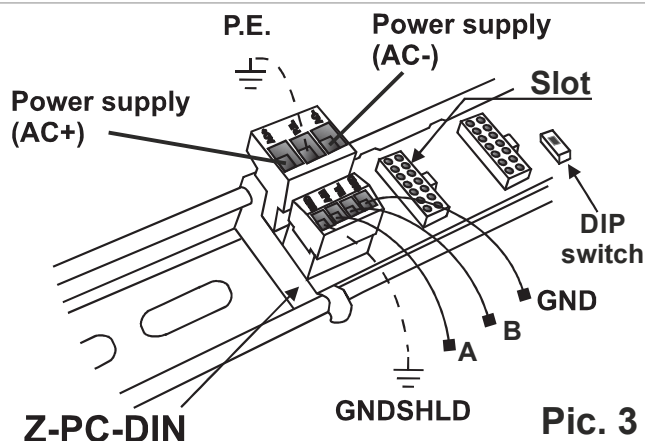

Pic. 3

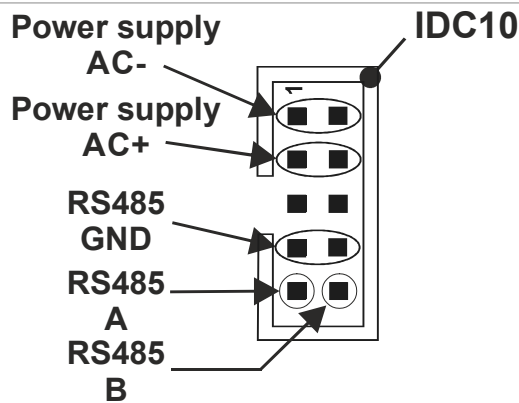

Pic. 4

In case of Z-PC-DINAL2-17,5 accessory use, the signals may be provided by terminal blocks. The figure shows the meaning of the terminals and the position of the DIP-switch (present on each DIN rail supports listed on Accessories) for network termination (not used in case of Modbus network). GNDSHLD: Shield to protect the signal inside the connection cables from electromagnetic disturbances (recommended).

ELECTRICAL CONNECTIONS

• POWER SUPPLY

19 – 28V \sim 50 – 60 Hz
10 – 40V \equiv 0.6 W Max

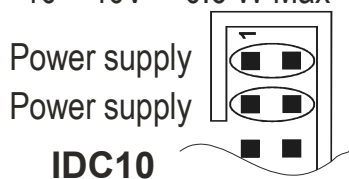

IDC10

Connect the IDC10 rear connector to provide power supply to module.

The supply voltage must be between:

10 and 40V \equiv (any polarity), or between 19 and 28 V \sim .

The upper limits must not be exceeded as this can seriously damage the module. If the power supply source is not protected against overload, a safety fuse of max. 2.5 A must be installed in the power supply line near the device.

• RS485

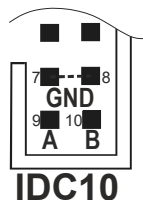

RS485

IDC10

Connection for RS485 communication with the Modbus master system through Z-PC-DINAL2-17.5 accessory.

Note: the indication of the RS485 connection polarity is not standardised and in some masters may be inverted

ELECTRICAL CONNECTIONS

• 8 NTC INPUTS

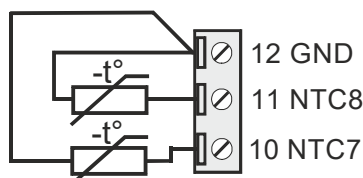
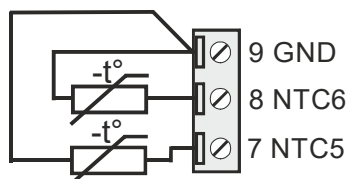
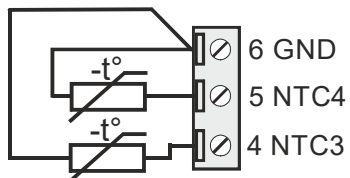
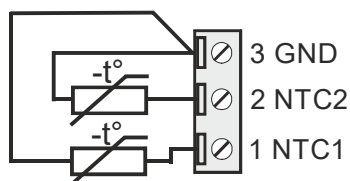

The module allows:

resistors measurement within a range from 100 Ω to 500 k Ω or
thermistors measurement within a range from 1 k Ω to 50 k Ω .

3, 6, 9 and 12 terminals are internally connected to the same ground within the device.

If you want to measure resistors or thermistors with resistance < 1 k Ω then the conductors resistance introduces an important measurement error. If the length of the cable does not exceed 100 m. you can reduce this error by using wires with a section greater than 1 mm².

You can also compensate this error using the configuration software.

The resistors and thermistors must be individually connected with two wires better if using shielded cable with a twisted pair for each channel.

REGISTRI MODBUS

Detailed information about the list of MODBUS registers and their functions can be found within the **USER MANUAL**.

IMPOSTAZIONI

The **EASY SETUP** configuration software, allows the parameter setting.



This software is available for free on the Internet site: www.seneca.com.

Some parameters can also be set using **DIP-switches**.

CONFIGURATIONS

DIP-SWITCHES

Before setting the DIP switches, in order to avoid damage to the module, you must disconnect the power supply. The DIP-switches position defines the Modbus Address and Baud Rate communication parameters. In the following table the Baud Rate and Address values are listed as a function of the DIP-switches position:

SW1	BAUD RATE	SW1	ADDRESS	SW1	TERMINATOR
1 2		3 4 5 6 7 8		9 10	
↓ ↓	9600	↓ ↓ ↓ ↓ ↓ ↑	# 1	x ↓	DISABLED
↓ ↑	19200	↓ ↓ ↓ ↓ ↓ ↓	# 2	x ↑	ENABLED
↑ ↓	38400	#..		ON
↑ ↑	57600	↑ ↑ ↑ ↑ ↑ ↑	# 63		
↓ ↓	FROM EEPROM	↓ ↓ ↓ ↓ ↓ ↓	FROM EEPROM		OFF
				X	Not Used

Note: If switches from 3 to 8 are in OFF position, communication settings are retrieved from EEPROM.

2nd Note: The termination of the RS485 line must be carried out only at the ends of the communication line.

FACTORY SETTINGS

DEFAULT CONDITION FOR THE CONFIGURATION PARAMETERS OF THE MODULE:

All DIP-switches at OFF position ↓

RS485 MODBUS protocol communication parameters: 38400 8,N,1 Addr. 1

ORDER CODES

Code	Description
Z-8NTC	RS485 Modbus RTU protocol module with 8 NTC inputs
Z-PC-DINAL2-17,5	Modbus CEI EN 60715 rail connections system - Z-PC Line

CONTACTS

Technical support	support@seneca.it
Product Informations	sales@seneca.it



**SCATTERGOOD
& JOHNSON LTD**
ELECTRICAL ENGINEERING & FLUID CONTROL DISTRIBUTORS

Est.1899

At Scattergood & Johnson Ltd, we pride ourselves on being a technical distributor to specialist industries.

Working with a range of quality product manufacturers across a number of specialist markets, we are not your average 'box shifter' - we are your technical and supply chain partner.

We fully support every product we sell - for free! Our internal team and external sales engineers can answer any product or application question, no matter the complexity.

Backing up this technical ability is a range of 50,000+ products available from stock for nationwide next day delivery (same day if required!), or you can collect what you need from any of our trade counters around the UK.

Select your specialist interest below to learn more about how we can help.



Online, In Branch and On the Road - Scattergood & Johnson Ltd, there when you need us.

www.scatts.co.uk