

MANUAL

PMI14V-F112-...-IO-...
Inductive Positioning System
with IO-Link

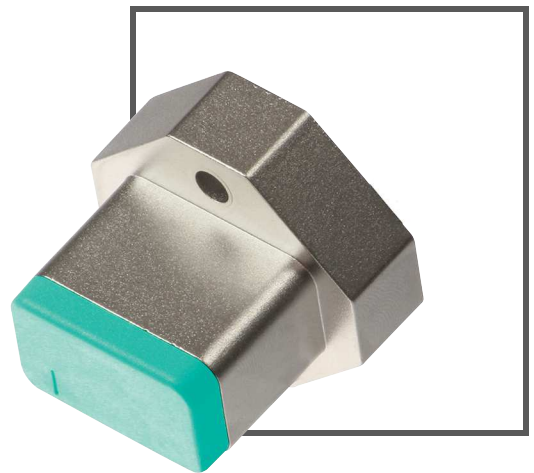

With regard to the supply of products, the current issue of the following document is applicable: The General Terms of Delivery for Products and Services of the Electrical Industry, published by the Central Association of the Electrical Industry (Zentralverband Elektrotechnik und Elektroindustrie (ZVEI) e.V.) in its most recent version as well as the supplementary clause: "Expanded reservation of proprietorship"

1	Introduction	5
2	Declaration of Conformity	6
3	Safety	7
3.1	Symbols Used	7
3.2	Intended Use	7
3.3	General Safety Instructions	7
4	Product Description	9
4.1	Use and Application.....	9
4.2	Scope of Delivery.....	9
4.3	Accessories.....	9
4.3.1	Damping Element.....	9
4.3.2	Parameterization Aids.....	10
4.3.3	4-Pin M8 Connection Cable.....	10
4.3.4	5-Pin M12 x 1 Connection Cable	11
5	Installation	12
5.1	Safety Information.....	12
5.2	Definition of the Measuring Range/Position.....	12
5.3	Preparation	12
5.4	Mounting.....	13
5.5	Connection	13
6	Commissioning	15
6.1	Commissioning without IO-Link.....	15
6.2	Commissioning with IO-Link to a Controller	15
6.3	Commissioning with IO-Link in an FDT Environment.....	15

7	IO-Link Programming	16
7.1	Overview	16
7.1.1	Identification Menu Item	16
7.1.2	"Parameter" Menu Item	17
7.1.3	Observation Menu Item	18
7.1.4	"Diagnosis" Menu Item	18
7.1.5	Process Data Menu Item	19
7.1.6	Process Data Structure Menu Item	19
7.1.7	"Events" Menu Item	20
7.1.8	Info Menu Item	20
8	Normal Operation	21
8.1	LED Indicator Properties	21
8.2	Position Values in the Event of an Error	21
8.3	Analog Voltage Output in the Event of an Error	22
9	Maintenance and Repair	24
9.1	Maintenance	24
9.2	Resetting the Output Functions to the Factory Default	24
10	Troubleshooting	25
10.1	What to Do in the Event of an Error	25
11	Appendix	26
11.1	Process Data Structure	26
11.2	Switching Signal Modes	27
11.3	Telegram Types	28
11.3.1	IO-Link Communication and ID Parameters	28
11.3.2	IO-Link Standard Parameters	29
11.3.3	IO-Link Device Parameters	30
11.3.4	Error Codes	33
11.3.5	Event Data	34

1 Introduction

Congratulations

You have chosen a device manufactured by Pepperl+Fuchs. Pepperl+Fuchs develops, produces and distributes electronic sensors and interface modules for the market of automation technology on a worldwide scale.

Please read the operating instructions carefully before installing this device and putting it into operation. The instructions and notes contained in this document will guide you step-by-step through the installation and commissioning procedures to ensure trouble-free use of this product. By doing so, you:

- Guarantee safe operation of the device
- Can utilize the entire range of device functions
- Avoid faulty operation and associated errors
- Reduce costs associated with downtime and incidental repairs
- Increase the effectiveness and operating efficiency of your plant.



Note!

Store these instructions somewhere safe in order to have them available for future work on the device.

Contact

If you have any questions about the device, its functions, or accessories, please contact us at:

Pepperl+Fuchs GmbH
Lilienthalstraße 200
68307 Mannheim, Germany
Telephone: +49 (0)621 776-1111
Fax: +49 (0)621 776-271111
Email: fa-info@de.pepperl-fuchs.com

2 Declaration of Conformity

This product was developed and manufactured under observance of the applicable European standards and guidelines.



Note!

A Declaration of Conformity can be requested from the manufacturer.

The product manufacturer, Pepperl+Fuchs GmbH, D-68307 Mannheim, has a certified quality assurance system that conforms to ISO 9001.



3 Safety

3.1 Symbols Used

Safety-Relevant Symbols



Danger!

This symbol indicates an imminent danger.

Non-observance will result in personal injury or death.



Warning!

This symbol indicates a possible fault or danger.

Non-observance may cause personal injury or serious property damage.



Caution!

This symbol indicates a possible fault.

Non-observance could interrupt the device and any connected systems and plants, or result in their complete failure.

Informative Symbols



Note!

This symbol brings important information to your attention.



Action

This symbol indicates a paragraph with instructions. You are prompted to perform an action or a sequence of actions.

3.2 Intended Use

The F112 inductive positioning system is optimized for highly accurate, continuous position detection. Based on the precise evaluation of several coil systems, the device combines a proven inductive sensor with innovative microcontroller technology. The compact design of the F112 enables position detection tasks to be carried out in a noncontact, wear-free process to a measuring length of 14 mm, even in confined installation locations.



Note!

The optimum measurement accuracy is achieved at an actuator distance of 1 mm ... 2 mm.

Only use recommended original accessories.

3.3 General Safety Instructions

Responsibility for planning, assembly, commissioning, operation, maintenance, and dismantling lies with the plant operator.

Installation and commissioning of all devices may only be performed by trained and qualified personnel.

User modification and or repair are dangerous and will void the warranty and exclude the manufacturer from any liability. If serious faults occur, stop using the device. Secure the device against inadvertent operation. In the event of repairs, return the device to your local Pepperl+Fuchs representative or sales office.

**Note!****Disposal**

Electronic waste is hazardous waste. When disposing of the equipment, observe the current statutory requirements in the respective country of use, as well as local regulations.

4 Product Description

4.1 Use and Application

The PMI14V-F112-...-IO-... inductive positioning system with IO-Link is designed to detect minimal changes in position in a noncontact process. The measurements are performed within a range of 14 mm with a high level of accuracy. As a general rule, position detection is achieved by attaching a damping element.

A typical area of application for the PMI14V-F112-...-IO-... is monitoring spindles in clamping systems.

What is IO-Link?

IO-Link is a new dimension of communication of and with sensors. The possibility of making the intelligence that is already integrated in each and every sensor fully available to users opens up new possibilities for automation. The use of IO-Link produces positive effects for all fields of application in factory automation. The technology offers particular benefits with regard to servicing (troubleshooting, maintenance, and device replacement), during the commissioning process (cloning, identification, configuration, and localization) and during operation (job changeover, continuous parameter monitoring, and online diagnostics). Reducing the variety of interfaces offers users significant savings potential. This variety of interfaces often results from having analog sensor inputs and the complex installation required in this case.

4.2 Scope of Delivery

- PMI14V-F112-...-IO-...
- Quick reference guide

The device description (IODD) can be found in the download area of the Pepperl+Fuchs website at www.pepperl-fuchs.com and in the product information for the PMI14V-F112-...-IO-....

4.3 Accessories

Various accessories are available.

4.3.1 Damping Element

We recommend using the BT-F90-W damping element.

BT-F90-W

Material: ST37 steel

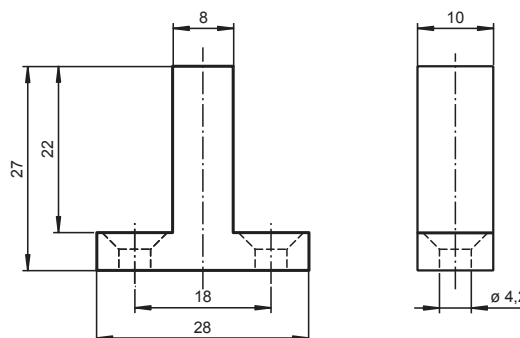

Using Your Own Damping Element

In principle, it is possible to use your own damping element. The damping element must have the following properties to be able to make use of the sensor's specified accuracy:

Material: construction steel such as S235JR+AR (previously St37-2)

Dimensions (L x W x H): $\geq 18 \text{ mm} \times 8 \text{ mm} \times \geq 4 \text{ mm}$

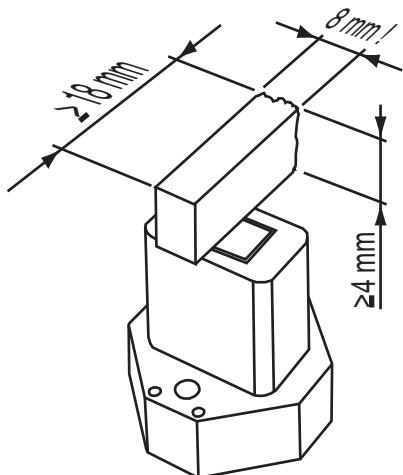
**Note!**

The exact width of the damping element of $8\text{ mm} \pm 0.1\text{ mm}$ must be observed. The edges should be broken with a maximum chamfer of 0.1 mm . If the width of the damping element deviates from this value, the position values will differ.



4.3.2 Parameterization Aids

The following parameterization aids are available:

Designation	Description
PACTware	FDT framework application for operating IODDs and DTMs
PMI14V-F112 IODD	IO Device Description — device description for operating the sensor, integrated in the system environment
IODD Interpreter DTM	Software for integrating IODDs within a FDT framework application (e.g., PACTware)
IO-Link-Master01-USB	USB to IO-Link adapter box for controlling an IO-Link sensor directly via a PC
IO-Link-Master-USB DTM	Device type manager — software for operating the master via FDT

4.3.3 4-Pin M8 Connection Cable



Below is a list of single-ended female cordsets suitable for establishing the electrical connection for PMI14V-F112-...-IO-V31 devices:

Illustration	Material	Length	4-pin M8 single-ended female cordsets	M8 cordset, 4-pin to M12, 4-pin
	PVC	2 m 5 m 10 m	V31-GM-2M-PVC V31-GM-5M-PVC V31-GM-10M-PVC	
	PUR	2 m 5 m 10 m	V31-GM-2M-PUR V31-GM-5M-PUR V31-GM-10M-PUR	V31-GM-2M-PUR-V1-G V31-GM-5M-PUR-V1-G V31-GM-10M-PUR-V1-G
	PVC	2 m	V31-WM-2M-PVC	
	PUR	2 m	V31-WM-2M-PUR	

Other lengths on request. If the cordset is to be used in environments with significant potential for electromagnetic interference, please use shielded single-ended female cordsets from our extensive range of accessories.

4.3.4 5-Pin M12 x 1 Connection Cable

Below is a list of single-ended female cordsets suitable for establishing the electrical connection for PMI14V-F112-...-IO-V15 devices:

Illustration	Material	Length	M12 x 1 single-ended female cordset, 5-pin	M12 x 1 cordset, 5-pin
	PVC	2 m 5 m 10 m	V15-G-2M-PVC V15-G-5M-PVC V15-G-10M-PVC	V15-G-2M-PVC-V15-G V15-G-5M-PVC-V15-G V15-G-10M-PVC-V15-G
	PUR	2 m 5 m 10 m	V15-G-2M-PUR V15-G-5M-PUR V15-G-10M-PUR	V15-G-2M-PUR-V15-G V15-G-5M-PUR-V15-G V15-G-10M-PUR-V15-G
	PVC	2 m	V15-W-2M-PVC	
	PUR	2 m	V15-W-2M-PUR	V15-W-2M-PUR-V15-G

Other lengths on request. If the cordset is to be used in environments with significant potential for electromagnetic interference, please use shielded single-ended female cordsets from our extensive range of accessories.

5 Installation

5.1 Safety Information



Caution!

Risk of short circuit

Carrying out work while the system is energized may result in damage to the device.

- Always disconnect the supply voltage before carrying out work on the device.
- Only connect the device to the supply voltage once all work has been completed.

5.2 Definition of the Measuring Range/Position

A reference mark (1) indicates the start of the measuring range on the positioning system.

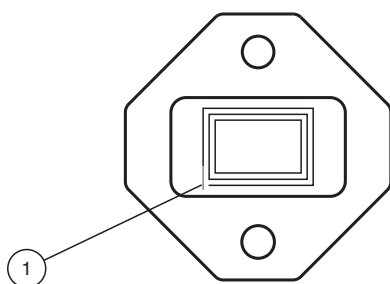

The position of the damping element defined by the positioning system relates to half of the width (center) of the damping element. The measuring range begins and ends with the half coverage provided by the damping element when moving lengthwise.

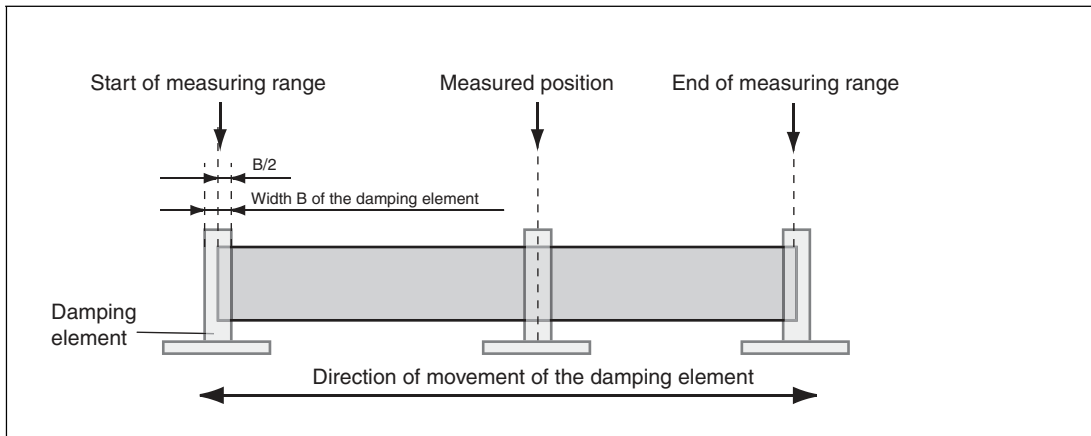

Figure 5.1

5.3 Preparation



Unpacking the device

1. Check the packaging and contents for damage.
 - ↳ In the event of damage, inform the shipping company and notify the supplier.
2. Check the package contents against your order and the shipping documents for completeness and accuracy.
 - ↳ Should you have any questions, direct them to Pepperl+Fuchs.
3. Retain the original packaging in case the device is to be stored or shipped again at a later date.

5.4 Mounting

- A flush mount is possible in metallic and nonmetallic environments.
- The distance between the measuring field (framed area at the front of the sensor) and the mounting base or fastening screws on the damping element must be at least 3 mm.

Watch out for any protruding metal parts such as screw heads when mounting the device.
- The damping element must be attached to the sensor at a right angle to guarantee the relevant measurement accuracy.
- The distance between the damping element and the sensor can be a maximum of 2.5 mm and must be at least 1 mm.

Distance of the Damping Element

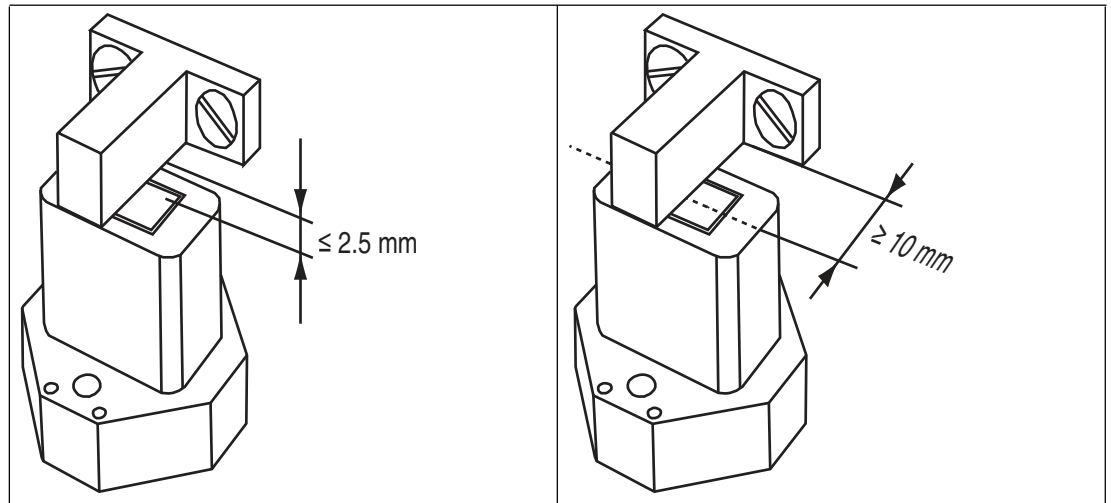

5.5 Connection



Connecting the supply voltage

To supply voltage to the sensor, proceed as follows:

1. Insert the prepared connection cable into the connector plug provided for this purpose on the underside of the housing.
2. Screw the cap nut onto the connector plug as far as it will go. This ensures that the power cable cannot be inadvertently pulled out.
3. Now connect the supply voltage to the cable provided.
 - ↳ The sensor is now ready for operation.



Activation via IO-Link

To prepare the sensor for activation via IO-Link, proceed as follows:

1. Connect the sensor to an IO-Link master. Use a 4-strand or 5-strand sensor cable for the connection.
2. Screw the cap nuts onto the connector plug as far as they will go. This ensures that the cable cannot be inadvertently pulled out.

↳ The sensor is now prepared for IO-Link communication.





Sensor	Electrical Connection	Pinout
PMI14V-F112-U-IO-V31 PMI14V-F112-U-IO-V31-Y...		
PMI14V-F112-2EP-IO-V31		
PMI14V-F112-2EPE2-IO-V15		
PMI14V-F112-2EPE2-IO		

Table 5.1
 1:BN (brown)
 2:WH (white)
 3:BU (blue)
 4:BK (black)
 5:GY (gray)

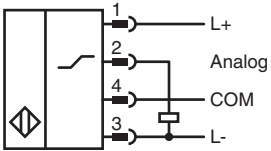

Note!

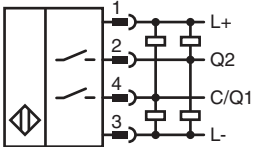
The list of electrical connections above represents just some of the products in our range of positioning systems equipped with IO-Link. The list does not claim to be complete. Please refer to the datasheet for the connection diagram for your sensor. This datasheet is available to download from the Pepperl+Fuchs website at www.pepperl-fuchs.com.

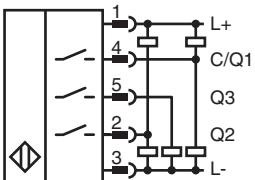
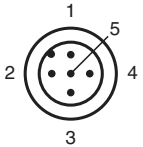
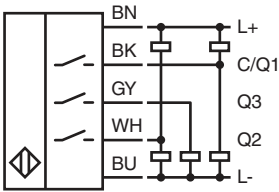
6 Commissioning

6.1 Commissioning without IO-Link



1. Check that the distance between the damping element and the sensor is correct (See chapter 5.4).
2. Switch on the supply voltage. The operating indicator on the sensor lights up green.
↳ The sensor will now function using the preset parameters.



Note!

Changes to the configuration can only be made by parameterizing via IO-Link!

6.2 Commissioning with IO-Link to a Controller



To activate the sensor via IO-Link using a controller, proceed as follows:

1. Check the connection between the sensor and the IO-Link master.
2. Set the corresponding port on the IO-Link master to which the sensor is connected to IO-Link status.
3. Once communication has been successfully established, the green LED on the sensor will flash briefly in one-second intervals.
↳ The sensor can then be parameterized or diagnosed using the modulated application. The sensor sends the digital switching information and the position value as process data.

6.3 Commissioning with IO-Link in an FDT Environment



To activate the sensor via IO-Link in an FDT environment, proceed as follows:

1. Check the connection between the sensor and the IO-Link master.
2. Make sure that an FDT frame application (e.g., PACTware), the necessary DTMs (device type manager), and the IODD device description for the sensor, IO-Link master, and any required communication DTMs for upstream components (e.g., IO-Link master) are installed.
3. Establish a connection between the PACTware application (or other FDT environment) and the sensor.
↳ You can now use the software to read data from the sensor or modify settings on the sensor.

7 IO-Link Programming

7.1 Overview

The sensor parameters are different for each device. These parameters are described in a standardized format in the device description IODD (IO Device Description). The IODD can be imported into various engineering tools from different system providers, providing they support IODD. The sensor can then be parameterized or diagnosed using the relevant tool (e.g., PACTware) and a user interface generated from the IODD.



Note!

- Minimum and maximum values can be activated under individual menu items by checking the appropriate box. These are shown on the right of the corresponding fields.
- Cyclic update of dynamic variables can be activated under individual menu items by checking the appropriate box. This feature allows appropriate values to be read from and written into the sensor in cycles.



Note!

The screenshots below showing the IODD in the PACTware framework program relate to the PMI14V-F112-2EP-IO-V31 sensor. IODDs for other sensors may differ from these screenshots.

7.1.1 Identification Menu Item

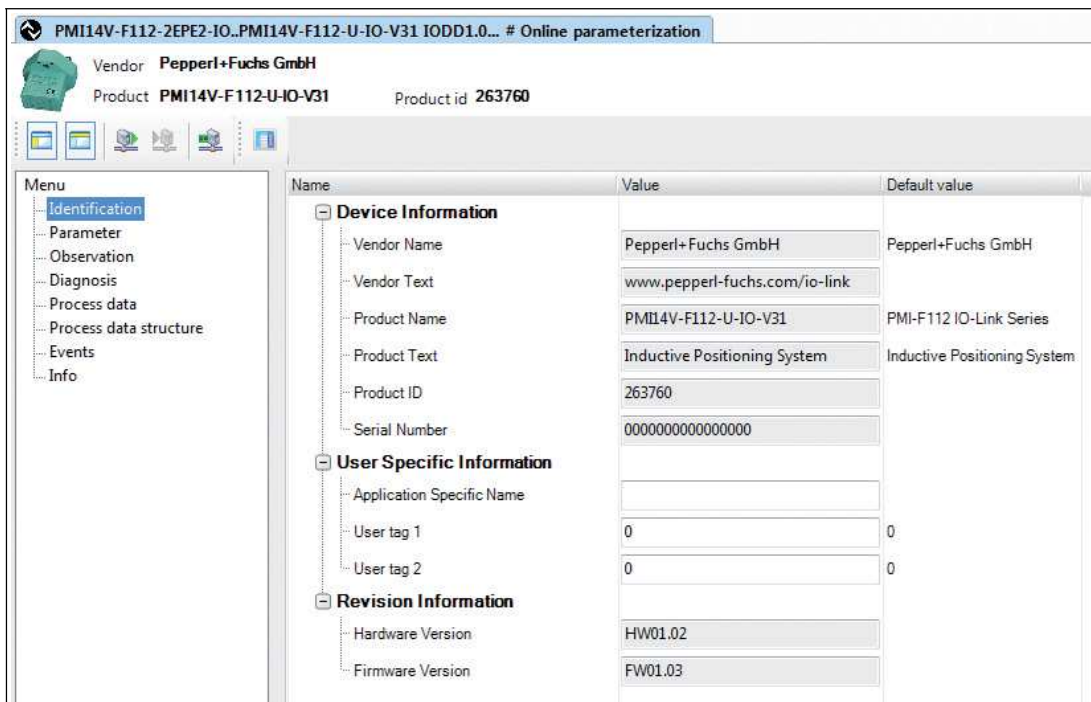

Name	Value	Default value
Device Information		
Vendor Name	Pepperl+Fuchs GmbH	Pepperl+Fuchs GmbH
Vendor Text	www.pepperl-fuchs.com/io-link	
Product Name	PMI14V-F112-U-IO-V31	PMI-F112 IO-Link Series
Product Text	Inductive Positioning System	Inductive Positioning System
Product ID	263760	
Serial Number	0000000000000000	
User Specific Information		
Application Specific Name		
User tag 1	0	0
User tag 2	0	0
Revision Information		
Hardware Version	HW01.02	
Firmware Version	FW01.03	

Figure 7.1 Menu item **Identification**

The "Identification" menu item is divided into three areas:

- Device Information:** Displays permanently programmed manufacturer and device information. These are read-only fields.
- User Specific Information:** These fields can be edited freely by the user, e.g., to keep several sensors of the same type apart within a network. Text information (strings) can be entered in the "Application Specific Name" field. Only numerical values can be entered in the "User tag 1" and "User tag 2" fields.

- **Revision Information:** Displays the firmware and hardware version. Please have this information ready when contacting our Service Center. These are read-only fields.

7.1.2 "Parameter" Menu Item

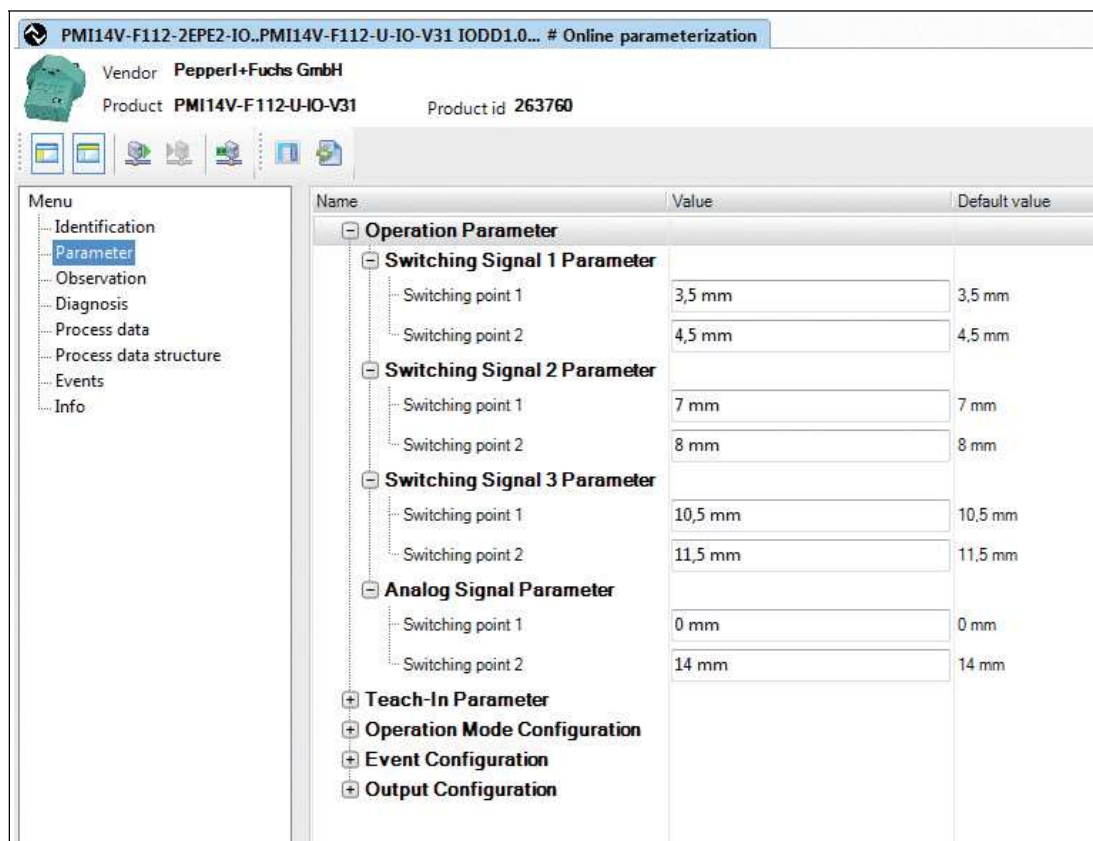
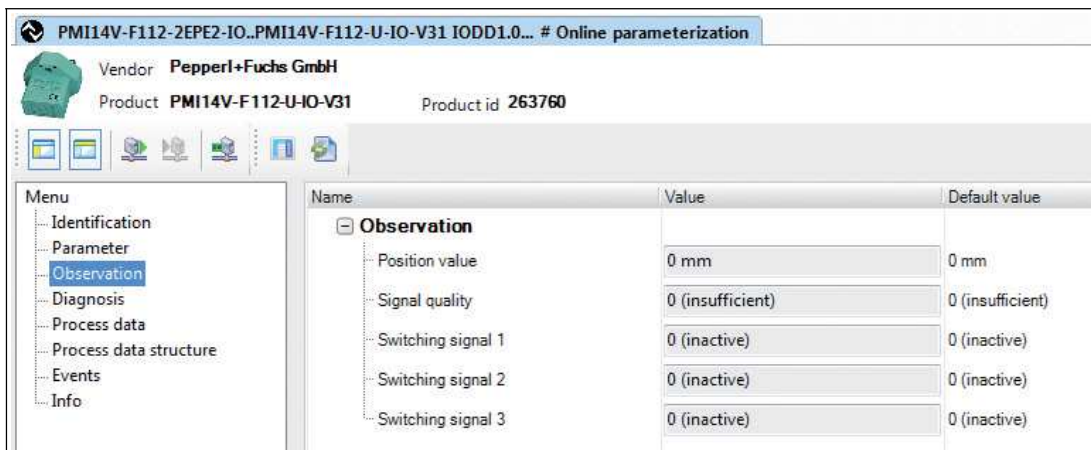

Figure 7.2 Menu item **Parameter**

All switching signals as well as the analog signal can be parameterized and configured in the "Parameter" menu item. The "Parameter" menu item is divided into five areas:

- **Operation Parameter:** Here you can set the switch points and limit values for the switching signal and the analog signal. The output operating modes are configured in the "Operation Mode Configuration" item.
- **Teach-In Parameter:** Here you can manually teach in the switching signals. To do this, place the damping element in the required position and teach in this position for the relevant switch point. The parameters are adopted permanently using system command 64 (Adopt Teach-in).
- **Operation Mode Configuration:** Here you can configure the switching and analog signals. Five switching signal modes (see chapter 11.2), inverted or non-inverted switching signal logic, switching signal hysteresis of 0 (normal) up to 2 (high), and the window width are available.
- **Event Configuration:** Here you can set whether or not instances of the damping element leaving the sensing range are logged as an error.
- **Output Configuration:** Here you can set the output type for Q1 and Q2 (push-pull, sinking, sourcing).

7.1.3 Observation Menu Item



Name	Value	Default value
Observation		
Position value	0 mm	0 mm
Signal quality	0 (insufficient)	0 (insufficient)
Switching signal 1	0 (inactive)	0 (inactive)
Switching signal 2	0 (inactive)	0 (inactive)
Switching signal 3	0 (inactive)	0 (inactive)

Figure 7.3 Menu item **Observation**

The "Observation" menu item displays the position value, signal quality, and the statuses of individual switching signals. These are read-only fields.

7.1.4 "Diagnosis" Menu Item

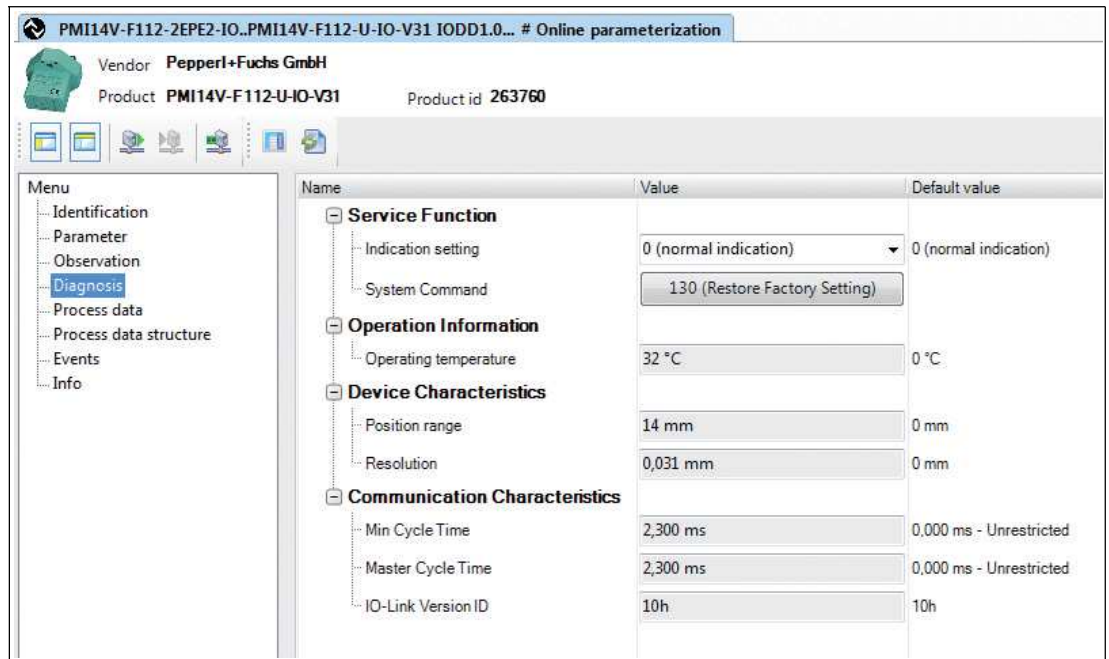
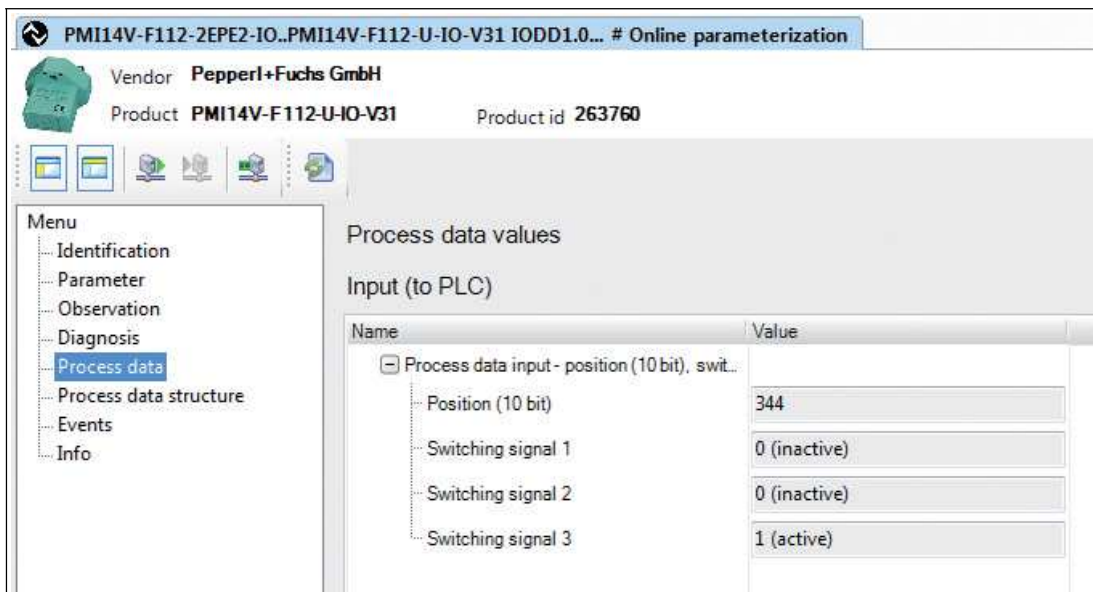

Figure 7.4 Menu item **Diagnosis**

The "Diagnosis" menu item is divided into four areas.

- **Service Function:** The following options are available:
 - **Indication setting:** Configuring the display setting causes the LED indicators to flash in a specific rhythm. This function is designed to make it easier to locate a sensor within a system (locator function).
 - **System Command:** Activating the **130 (restore default settings)** button resets the sensor to the default settings. All previous parameter changes are lost as a result of this.
- **Operation Information:** Provides details of the operating temperature. This is a read-only field.
- **Device Characteristics:** Provides details of the detection range and the resolution. These are read-only fields.
- **Communication Characteristics:** Provides details of the minimum cycle time, master cycle time, and IO-Link version ID. These are read-only fields.

7.1.5 Process Data Menu Item



PMI14V-F112-2EPE2-IO..PMI14V-F112-U-IO-V31 IOOD1.0... # Online parameterization

Vendor **Pepperl+Fuchs GmbH**
Product **PMI14V-F112-U-IO-V31** Product id **263760**

Menu

- Identification
- Parameter
- Observation
- Diagnosis
- Process data**
- Process data structure
- Events
- Info

Process data values

Input (to PLC)

Name	Value
<input type="checkbox"/> Process data input - position (10 bit), swit...	
Position (10 bit)	344
Switching signal 1	0 (inactive)
Switching signal 2	0 (inactive)
Switching signal 3	1 (active)

Figure 7.5 Menu item **Process data**

The "Process data" menu item displays the position of the damping element as a decimal value (1/32 mm) and the status of the switching signals. These are read-only fields.

7.1.6 Process Data Structure Menu Item

PMI14V-F112-2EPE2-IO..PMI14V-F112-U-IO-V31 IODD1.0... # Online parameterization

Vendor **Pepperl+Fuchs GmbH**
 Product **PMI14V-F112-U-IO-V31** Product id **263760**

Menu

- Identification
- Parameter
- Observation
- Diagnosis
- Process data
- Process data structure**
- Events
- Info

Input process data structure

Name	Bit offset	Bit length
[-] Process data input - position (10 bit), swit...	0	16
Position (10 bit)	6	10
Switching signal 1	0	1
Switching signal 2	1	1
Switching signal 3	2	1

Figure 7.6 Menu item **Process data structure**

The "Process data structure" menu item displays the bit assignment of the position data and the digital switching signals. These are read-only fields.

7.1.7 "Events" Menu Item

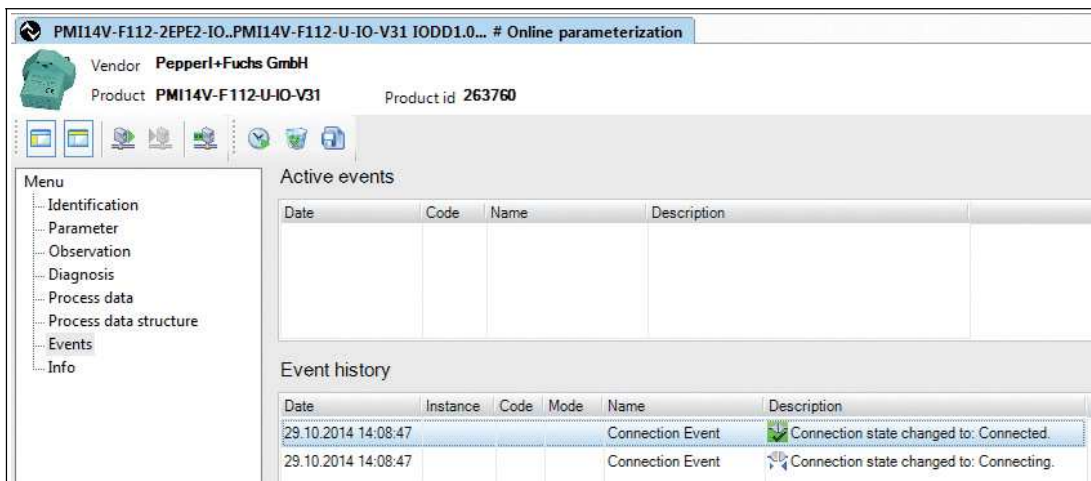

PMI14V-F112-2EPE2-IO..PMI14V-F112-U-IO-V31 IODD1.0... # Online parameterization

Vendor **Pepperl+Fuchs GmbH**
 Product **PMI14V-F112-U-IO-V31** Product id **263760**

Menu

- Identification
- Parameter
- Observation
- Diagnosis
- Process data
- Process data structure
- Events**
- Info

Active events

Date	Code	Name	Description

Event history

Date	Instance	Code	Mode	Name	Description
29.10.2014 14:08:47				Connection Event	Connection state changed to: Connected.
29.10.2014 14:08:47				Connection Event	Connection state changed to: Connecting.

Figure 7.7 Menu item **Events**

The "Events" menu item details all current and past events when the "Activate event monitor" checkbox is ticked. These are read-only fields.

7.1.8 Info Menu Item

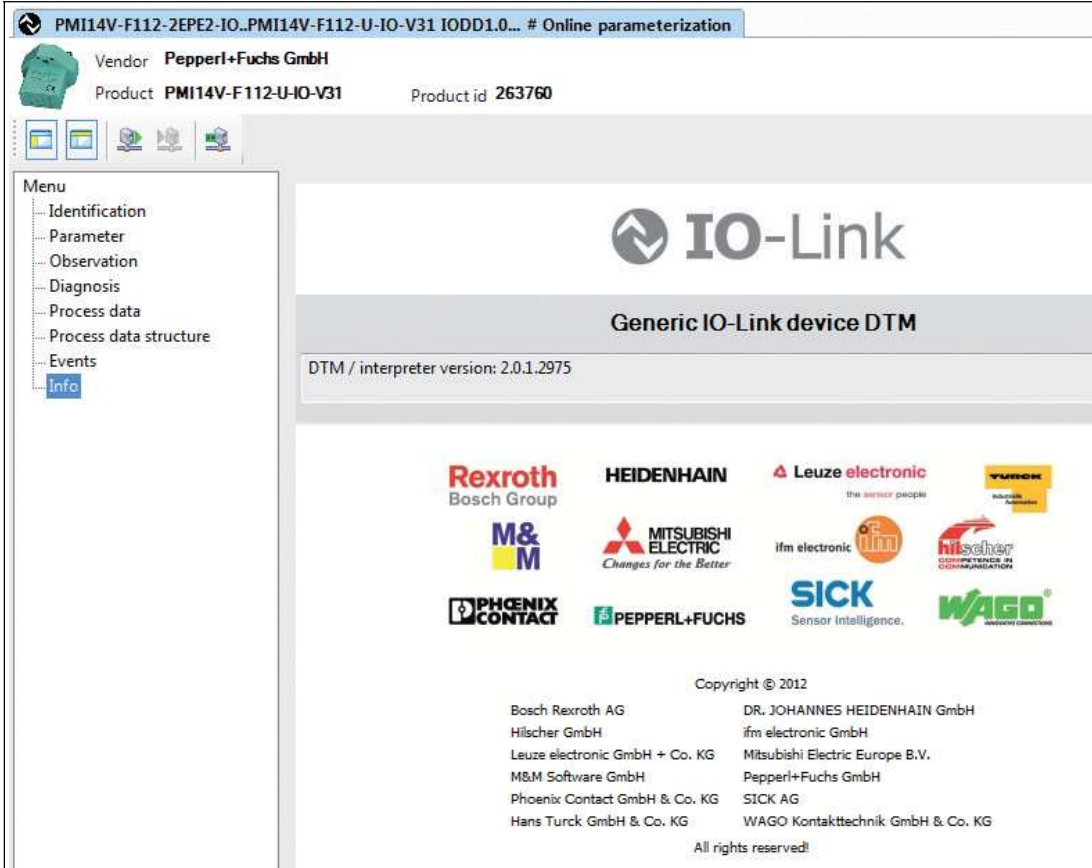

PMI14V-F112-2EPE2-IO..PMI14V-F112-U-IO-V31 IODD1.0... # Online parameterization

Vendor **Pepperl+Fuchs GmbH**
Product **PMI14V-F112-U-IO-V31** Product id **263760**





Menu





- Identification
- Parameter
- Observation
- Diagnosis
- Process data
- Process data structure
- Events
- Info**





IO-Link

Generic IO-Link device DTM

DTM / interpreter version: 2.0.1.2975

Copyright © 2012

Bosch Rexroth AG	DR. JOHANNES HEIDENHAIN GmbH
Hilscher GmbH	ifm electronic GmbH
Leuze electronic GmbH + Co. KG	Mitsubishi Electric Europe B.V.
M&M Software GmbH	Pepperl+Fuchs GmbH
Phoenix Contact GmbH & Co. KG	SICK AG
Hans Turck GmbH & Co. KG	WAGO Kontakttechnik GmbH & Co. KG

All rights reserved!

Figure 7.8 Menu item **Info**

The "Info" menu item displays the DTM/interpreter version and all companies that support IO-Link. These are read-only fields.



8 Normal Operation

8.1 LED Indicator Properties

The LEDs on the PMI14V-F112-...-IO-... are used to indicate the different sensor statuses.

Indication Mode	Code	Representation	Typical
Power off	NPI	Permanently off	
Power on	POI	Permanently on	
Short circuit	SCI	Flashing	4 Hz
Undervoltage	UVI	Dual flash	0.8 Hz
IO-Link communication	IOI	Brief interruption	1.0 Hz
Locator indication	LOI	Dual flash	1.0 Hz

8.2 Position Values in the Event of an Error

Position values without fault values ("Error Replacement" parameter deactivated see chapter 11.3.3)

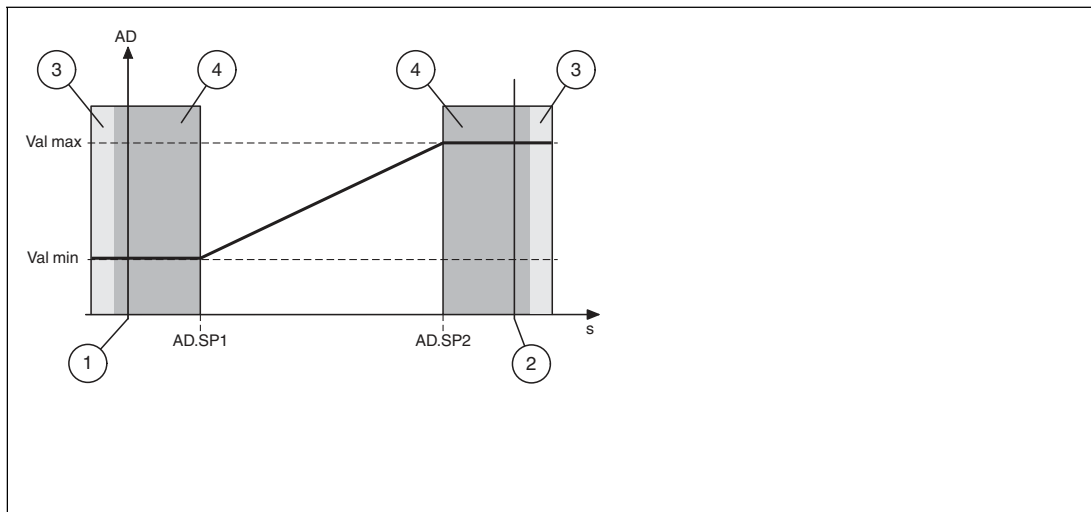

AD: position value
Val max: maximum position value
Val min: minimum position value
AD.SP1: position value setpoint 1
AD.SP2: position value setpoint 2

1: lower limit of detection range
2: upper limit of detection range
3: no damping element
4: outside of the measuring range



Note!

- When the sensor is switched on without a damping element, the analog output is set to the low voltage value.
- AD.SP2 < AD.SP1 does not invert the properties. This can be set using analog output mode. See chapter 7.1.2.

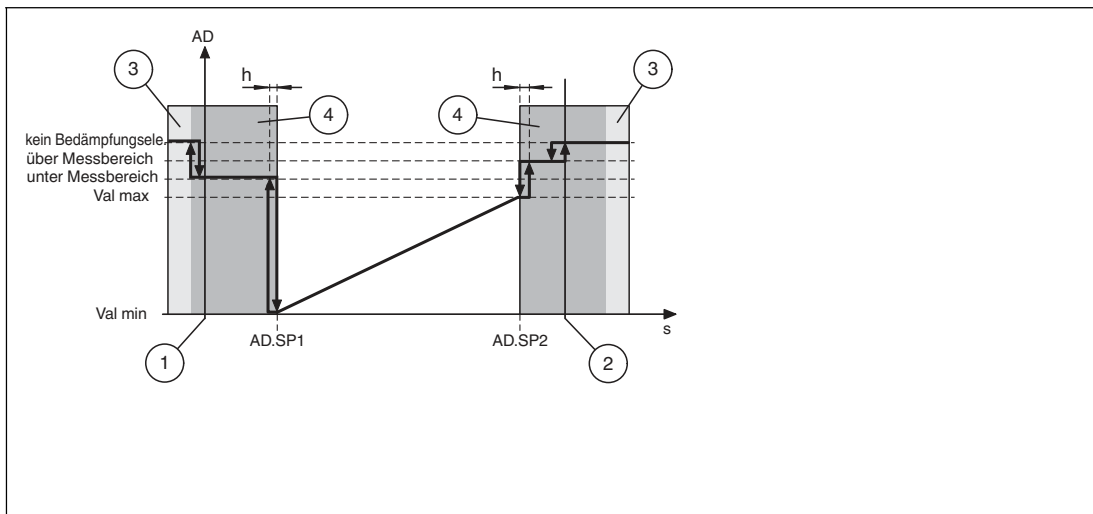
Position value with fault values ("Error Replacement" parameter activated see chapter 11.3.3)

AD: position value
 Val max: maximum position value
 Val min: minimum position value
 AD.SP1: position value setpoint 1
 AD.SP2: position value setpoint 2
 h: hysteresis

1: lower limit of detection range
 2: upper limit of detection range
 3: no damping element
 4: outside of the measuring range

Note!

- Fault values if "Error Replacement" is set accordingly (see chapter 11.3.3).
- AD.SP2 < AD.SP1 does not invert the properties. This can be set using analog output mode. See chapter 7.1.2.

8.3 Analog Voltage Output in the Event of an Error



Note!

This section only applies to devices with analog voltage output

Analog voltage output without fault values ("Error Replacement" parameter deactivated see chapter 11.3.3)

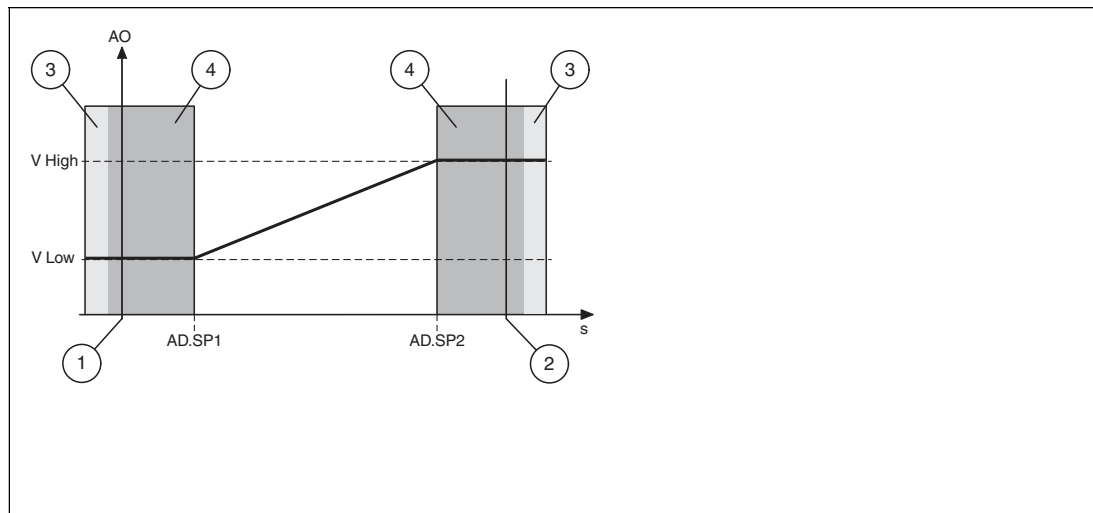

AO: analog output in volts
 V High: high voltage value
 V Low: low voltage value
 AD.SP1: position value setpoint 1
 AD.SP2: position value setpoint 2

1: lower limit of detection range
 2: upper limit of detection range
 3: no damping element
 4: outside of the measuring range



Note!

- If the device is switched on without a damping element, the analog output is set to the low voltage value.
- AD.SP2 < AD.SP1 does not invert the properties. This can be set using analog output mode. See chapter 7.1.2.

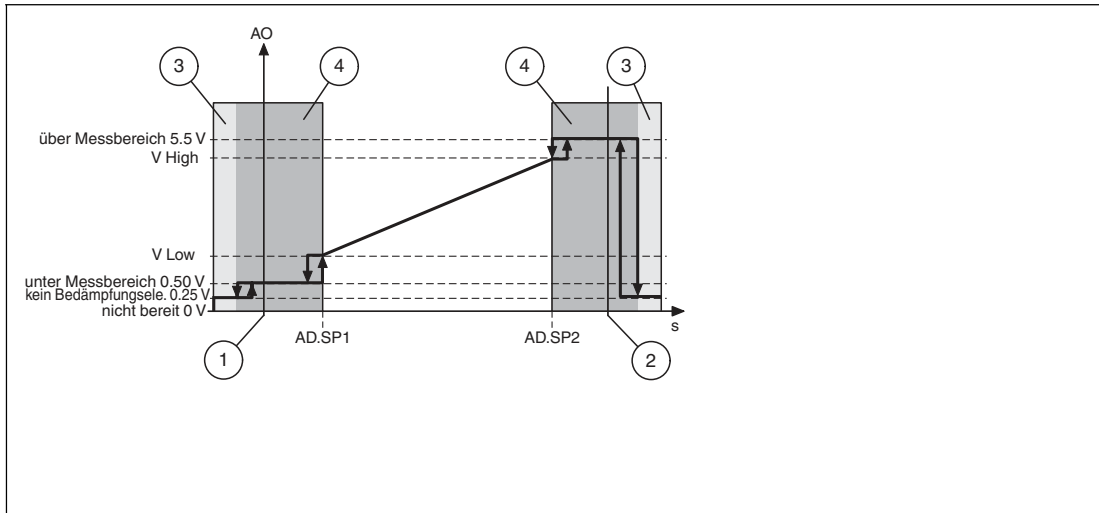
Analog voltage output with fault values ("Error Replacement" parameter activated see chapter 11.3.3)

AO: analog output in volts
 V High: high voltage value
 V Low: low voltage value
 AD.SP1: position value setpoint 1
 AD.SP2: position value setpoint 2

1: lower limit of detection range
 2: upper limit of detection range
 3: no damping element
 4: outside of the measuring range

Note!

- Fault values can only be used if the analog output is set to 1 V ... 5 V.
- AD.SP2 < AD.SP1 does not invert the properties. This can be set using analog output mode. See chapter 7.1.2.
- After the device is switched on, the sensor remains "not ready" until the first measurement has been carried out.



9 Maintenance and Repair

9.1 Maintenance

The sensor's transmission properties are stable over long periods. For this reason, regular adjustments to, and maintenance on the sensor itself, are not necessary. Nevertheless check in the course of normal maintenance intervals that the sensor, the actuator and the connector are securely attached. Also check that the connecting cable is intact and correctly routed.

9.2 Resetting the Output Functions to the Factory Default

The sensor can be reset via IO-Link only.see chapter 7.1.4

10 Troubleshooting

10.1 What to Do in the Event of an Error

Before requesting a service call, please check that the following actions have been taken:

- Test the equipment according to the following checklist.
- Telephone assistance has been obtained from the Service Center in order to isolate the problem.

Checklist

Fault	Cause	Remedy
"Operating indicator" LED does not light up	The power supply is switched off.	Check whether there is a reason why it is switched off (installation or maintenance work, etc.). Switch the power supply on if appropriate.
"Operating indicator" LED does not light up	The plug is not connected to the connector on the sensor.	Connect the plug to the sensor and tighten the cap nut by hand.
"Operating indicator" LED does not light up	Wiring fault in the splitter or switch cabinet.	Check the wiring carefully and repair any wiring faults.
"Operating indicator" LED does not light up	Supply cable to the sensor is damaged.	Replace the damaged cable.
No IO-Link connection to the device	The C/Q communication port on the sensor is not connected to the IO-Link master	Make sure that the C/Q communication port is connected to the IO-Link master.
No IO-Link connection to the device	No power supply	See error: "Operating indicator" LED does not light up
Object is not detected	Sensor is too far away from the item to be detected	Check the mounting and, if necessary, adjust the sensor to the correct distance

- If none of the above actions solves the problem, contact the Pepperl+Fuchs Service Center. Have details of the model number and firmware version of the sensor ready if possible.

11 Appendix

11.1 Process Data Structure

Input Process Data

15	14	13	12	11	10	9	8	7	6	5	4	3	2	1	0
Position value										0	0	0	Switching signals		
AD9	AD8	AD7	AD6	AD5	AD4	AD3	AD2	AD1	AD0	res	res	res	BD3	BD2	BD1

Function

BD1	Switching signal 1
BD2	Switching signal 2
BD3	Switching signal 3
AD	Position value

Values

BDn	Boolean	0	Switched off
		1	Switched on
AD	uint10	0 ... 448	Valid position value (1/32 mm)
		1021	Outside of the value range (below the value range)
		1022	Outside of the value range (above the value range)
		1023	No damping element

Configuration

BD1 switching point logic	idx 0x3D.1	
	0	1
BD1 — switching signal 1:		
Target outside of the limits	0	1
Target inside of the limits	1	0

BD2 switching point logic	idx 0x3F.1	
	0	1
BD2 — switching signal 2:		
Target outside of the limits	0	1
Target inside of the limits	1	0

BD3 switching point logic	idx 0x4001.1	
	0	1
BD3 — switching signal 3:		
Target outside of the limits	0	1
Target inside of the limits	1	0

11.2 Switching Signal Modes

The switching signal mode is configured via the IO-Link device parameter. See chapter 11.3.3.

In an FDT environment, the configuration process is executed under the "Parameter" menu item. See chapter 7.1.2.



Note!

To suppress unstable conditions, all setpoints (SP_x) are assigned a switching hysteresis *h*. The switching hysteresis can be set to normal (0.2 mm), medium (0.4 mm), and high (0.8 mm) values.

1. BD_n Inactive Mode

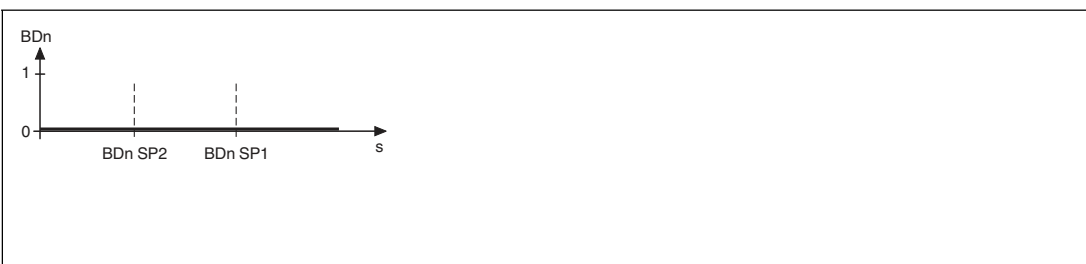

The output is not active.

2. BD_n Switching Threshold Mode

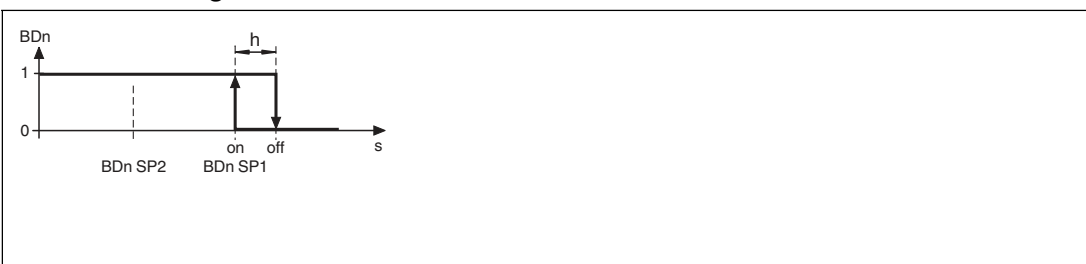

The output switches when the position value is lower than SP1. Any value set in SP2 is ignored.

3. BD_n Window Mode

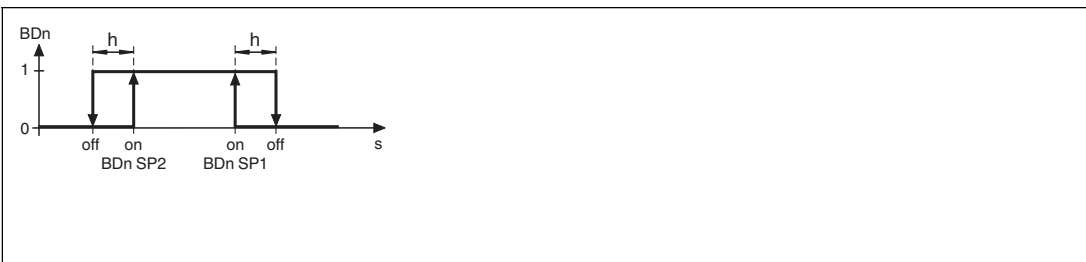

The output switches when an object is between SP1 and SP2.

4. BDn Two-Point Operating Mode



The output switches when the damping element falls below the SP2 position value and switches back when the damping element exceeds the SP1 position value.

5. BDn Centered Window Mode



Setpoint 1 (SP1) defines the center of the window.

The output switches when an object is within a range around SP1 defined by SP1 and the "centered window width." Corresponds to window mode with a defined window width. See chapter 11.3.3 Index 0x40.

11.3 Telegram Types

11.3.1 IO-Link Communication and ID Parameters

Address hex	Name	Type	Data type	Attribute	Value	Comment
Communication parameter						
0x00	Master command	R/W	uint8	Volatile		Written by master
0x01	Master cycle time	R/W	uint8	Volatile		Written by master
0x02	Min. cycle time	R	uint8	Constant	0x17	2.3 ms
0x03	Frame capability	R	uint8	Constant	0x01	ISDU support
0x04	IO-Link version ID	R	uint8	Constant	0x10	IO-Link version 1.0
0x05	Process data in	R	uint8	Constant	0x50	16bit Pdin, SIO support
0x06	Process data out	R	uint8	Constant	0x00	n/a
Validation parameter						
0x07	IO-Link vendor ID 1 (MSB)	R	uint8	Constant	0x00	Pepperl+Fuchs
0x08	IO-Link vendor ID 2 (LSB)	R	uint8	Constant	0x01	
0x09	Device ID 1 (MSB)	R	uint8	Constant	0x20	Inductive sensors PMI-F112 variant 1
0x0A	Device ID 2	R	uint8	Constant	0x01	
0x0B	Device ID 3 (LSB)	R	uint8	Constant	0x01	
0x0C	Function ID 1 (MSB)	R/W	uint8	Static	0x00	Not used
0x0C	Function ID 2 (LDB)	R/W	uint8	Static	0x00	

11.3.2 IO-Link Standard Parameters

System Command (idx 0x02)

Value hex	Value dec	Function
0x40	64	Teach apply
0x41	65	SP1 single value teach
0x42	66	SP2 single value teach
0x4F	79	Teach cancel
0x82	130	Restore factory settings

Profile ID (idx 0x0D)

Subindex	Value	Function
1	0x0001	Smart sensor profile supported
2	0x8000	Device identification
3	0x8001	Binary data channel
4	0x8002	Process data variable
5	0x8004	Teach channel

PD Input Descriptor (idx 0x0E)

Subindex	Value	Function
1	0x030100	SetFBool3.0
2	0x020A06	UIntegerT10.6

Parameters for Identification

Index hex	Index dec	Name	Type	Data type
0x10	16	Vendor name	R	char [18]
0x11	17	Vendor text	R	char [max 32]
0x12	18	Product name	R	char [max 32]
0x13	19	Product ID	R	char [11]
0x14	20	Product text	R	char [max 32]
0x15	21	Serial number	R	char [14]
0x16	22	Hardware revision	R	char [7]
0x17	23	Firmware revision	R	char [7]
0x18	24	Application specific name	R/W	char [max 32]

11.3.3 IO-Link Device Parameters

**Note!**

The existing indexes for the various sensors differ according to their properties. For example, indexes for parameterizing an analog output are only available for sensors with an analog output.

The same is true for the parameter values within an index. For example, settings for an analog current output are not available for a sensor with an analog voltage output.

A list of the available indexes can be found on the datasheet for your IO-Link sensor at www.pepperl-fuchs.com.

Index (hex)	Sub	Name	Type	Data type	Value	Default	Unit
Smart Sensor Profile parameters							
0x3A		Teach-in channel	R/W	uint8	0 ... 3	0	
0x3B		Teach-in status	R	uint8			
0x3C		BD1_SPV— switching signal 1	R/W	record			
	1	SP1—setpoint value 1	R/W	uint16	0 ... 448	112	1/32 mm
	2	SP2—setpoint value 2	R/W	uint16	0 ... 448	144	1/32 mm
0x3D		BD1_SPC— switching signal 1 configuration	R/W	record			
	1	switchpoint logic	R/W	uint8	0x00—not inverted 0x01—inverted 0x02 – 0xFF— not allowed	0x00	
	2	switchpoint mode	R/W	uint8	0x00—inactive 0x01—single-point mode 0x02—window mode 0x03—two-point mode 0x04 – 0x7F—reserved 0x80—centered window mode	0x80	
	3	switchpoint hysteresis	R/W	uint16	0: Normal 1: Medium 2: High	1	
0x3E		BD2_SPV— switching signal 1	R/W	record			
	1	SP1—setpoint value 1	R/W	uint16	0 ... 448	224	1/32 mm
	2	SP2—setpoint value 2	R/W	uint16	0 ... 448	256	1/32 mm
0x3F		BD2_SPC— switching signal 1 configuration	R/W	record			

Index (hex)	Sub	Name	Type	Data type	Value	Default	Unit
	1	switchpoint logic	R/W	uint8	0x00—not inverted 0x01—inverted 0x02 – 0xFF—not allowed	0x00	
	2	switchpoint mode	R/W	uint8	0x00—inactive 0x01—single-point mode 0x02—window mode 0x03—two-point mode 0x04 – 0x7F—reserved 0x80—centered window mode	0x80	
	3	switchpoint hysteresis	R/W	uint16	0: Normal 1: Medium 2: High	1	
0x4000		BD3_SPV—switching signal 1	R/W	record			
	1	SP1—setpoint value 1	R/W	uint16	0 ... 448	336	1/32 mm
	2	SP2—setpoint value 2	R/W	uint16	0 ... 448	368	1/32 mm
0x4001		BD3_SPC—switching signal 1 configuration	R/W	record			
	1	switchpoint logic	R/W	uint8	0x00—not inverted 0x01—inverted 0x02 – 0xFF—not allowed	0x00	
	2	switchpoint mode	R/W	uint8	0x00—inactive 0x01—single-point mode 0x02—window mode 0x03—two-point mode 0x04 – 0x7F—reserved 0x80—centered window mode	0x80	
	3	switchpoint hysteresis	R/W	uint16	0: Normal 1: Medium 2: High	1	
Device-specific operation parameters							
0x40		Centered window width	R/W	record			
	1	BD channel 1 width	R/W	uint16	0 ... 448	32	1/32 mm
	2	BD channel 2 width	R/W	uint16	0 ... 448	32	1/32 mm
	3	BD channel 3 width	R/W	uint16	0 ... 448	32	1/32 mm

2019-02

Index (hex)	Sub	Name	Type	Data type	Value	Default	Unit
0x42		AD_SPC—analog signal setpoint value	R/W	record			
	1	SP1—setpoint value 1	R/W	uint16	0 ... 448	0	
	2	SP1—setpoint value 2	R/W	uint16	0 ... 448	448	
0x43		AD_SPC—analog signal configuration	R/W	record			
	1	Analog output mode	R/W	uint8	0x00—rising ramp 0x01—falling ramp	0x00	
	2	Error value hysteresis	R/W	uint16	0: Normal 1: Medium 2: High	0	
	3	Error replacement values	R/W	uint8	0b0000 0000—disabled 0bXXXX XXX1—out-of-range enabled 0bXXXX XX1X—no target enabled	0	
0x5F		Measurement data collection	R	record			
	1	Position value	R	uint16	0 ... 448		1/32 mm
	2	Signal quality	R	uint8	0x00—insufficient/no position acquisition possible 0x01—acceptable 0x02—good 0x03—excellent		
	3	BD1 status	R	uint8	0: inactive 1: active		
	4	BD2 status	R	uint8	0: inactive 1: active		
	5	BD3 status	R	uint8	0: inactive 1: active		
Standard operation control							
0x70		Output configuration	R/W	record			
	1	Output type Q1	R/W	uint8	0x00—push-pull 0x01—low-side 0x02—high-side	0x00	

Index (hex)	Sub	Name	Type	Data type	Value	Default	Unit
	2	Output type Q2	R/W	uint8	0x00—push-pull 0x01—low-side 0x02—high-side 0x03—hi-Z	0x00	
	3	Output type Q3	R/W	uint8	0x02—high-side 0x03—hi-Z	0x02	
	4	Analog output type UI	R/W	uint8	0x03—U: 0 V ... 10 V 0x04—U: 1 V ... 5 V	0x03	
	5	Current low value	R/W	uint8	0 ... 200	0	0.1 mA
	6	Current high value	R/W	uint8	0 ... 200	200	0.1 mA
	7	Voltage low value	R/W	uint8	0 ... 100	0	0.1 V
	8	Voltage high value	R/W	uint8	0 ... 100	100	0.1 V
0x74		Event configuration	R/W	uint8	0b0000 0000—application events disabled 0bXXXX XXX1—no target event enabled	0x00	
0x7F		Locator indication control	R/W	uint8	0x00—normal indication 0x01—locator indication	0x00	
User information							
0xC0		UT1—user tag 1	R/W	uint32	0x00000000 ... 0xFFFFFFFF	0	
0xC1		UT2—user tag 2	R/W	uint16	0x0000 ... 0xFFFF	0	
Special function							
0xE2		Operating temperature	R	uint8			°C
0xE8		Device characteristics	R	record			
	1	Position range	R	uint16	448		
	2	Resolution	R	uint16	16		1/512 mm

11.3.4 Error Codes

In the event of a fault, the sensor transmits the following error codes:

Error code	Code	Comment
Invalid index	0x8011	R/W access to unavailable parameter index
Invalid subindex	0x8012	R/W access to unavailable parameter subindex
Service temporarily unavailable	0x8020	Access to parameters that are unavailable due to device status
Access denied	0x8023	Write attempt to read-only address
Invalid value range, parameter	0x8030	For all R/W parameters outside of the valid value range
Parameter value too large	0x8031	For all R/W parameters above the valid value range
Parameter value too small	0x8032	For all R/W parameters beneath the valid value range

11.3.5 Event Data

The sensor is capable of transmitting events that occur:

Event	Instance	Type	Mode	Event qualifier	Event code	Description
PDU buffer overflow	DL	Error	Single shot	0x72	0x5200	Sensor cannot process the transmitted data object due to the size
PDU checksum error	DL	Error	Single shot	0x72	0x5600	Inconsistency during transmission of the PDU data
PDU process error PDU flow control error	DL	Error	Single shot	0x72	0x5600	Asynchronicity during transmission of the PDU data
Unauthorized PDU service	AL	Error	Single shot	0x73	0x5800	Transmitted service request is invalid
No damping element	APP	Warning	Appear/Disappear	0xE4/0xA4	0x8CA4	No damping element or no position detection possible

FACTORY AUTOMATION – SENSING YOUR NEEDS



Worldwide Headquarters

Pepperl+Fuchs GmbH
68307 Mannheim · Germany
Tel. +49 621 776-0
E-mail: info@de.pepperl-fuchs.com

USA Headquarters

Pepperl+Fuchs Inc.
Twinsburg, Ohio 44087 · USA
Tel. +1 330 4253555
E-mail: sales@us.pepperl-fuchs.com

Asia Pacific Headquarters

Pepperl+Fuchs Pte Ltd.
Company Registration No. 199003130E
Singapore 139942
Tel. +65 67799091
E-mail: sales@sg.pepperl-fuchs.com

www.pepperl-fuchs.com

 **PEPPERL+FUCHS**
SENSING YOUR NEEDS



**SCATTERGOOD
& JOHNSON LTD**
ELECTRICAL ENGINEERING & FLUID CONTROL DISTRIBUTORS

Est.1899

At Scattergood & Johnson Ltd, we pride ourselves on being a technical distributor to specialist industries.

Working with a range of quality product manufacturers across a number of specialist markets, we are not your average 'box shifter' - we are your technical and supply chain partner.

We fully support every product we sell - for free! Our internal team and external sales engineers can answer any product or application question, no matter the complexity.

Backing up this technical ability is a range of 50,000+ products available from stock for nationwide next day delivery (same day if required!), or you can collect what you need from any of our trade counters around the UK.

Select your specialist interest below to learn more about how we can help.

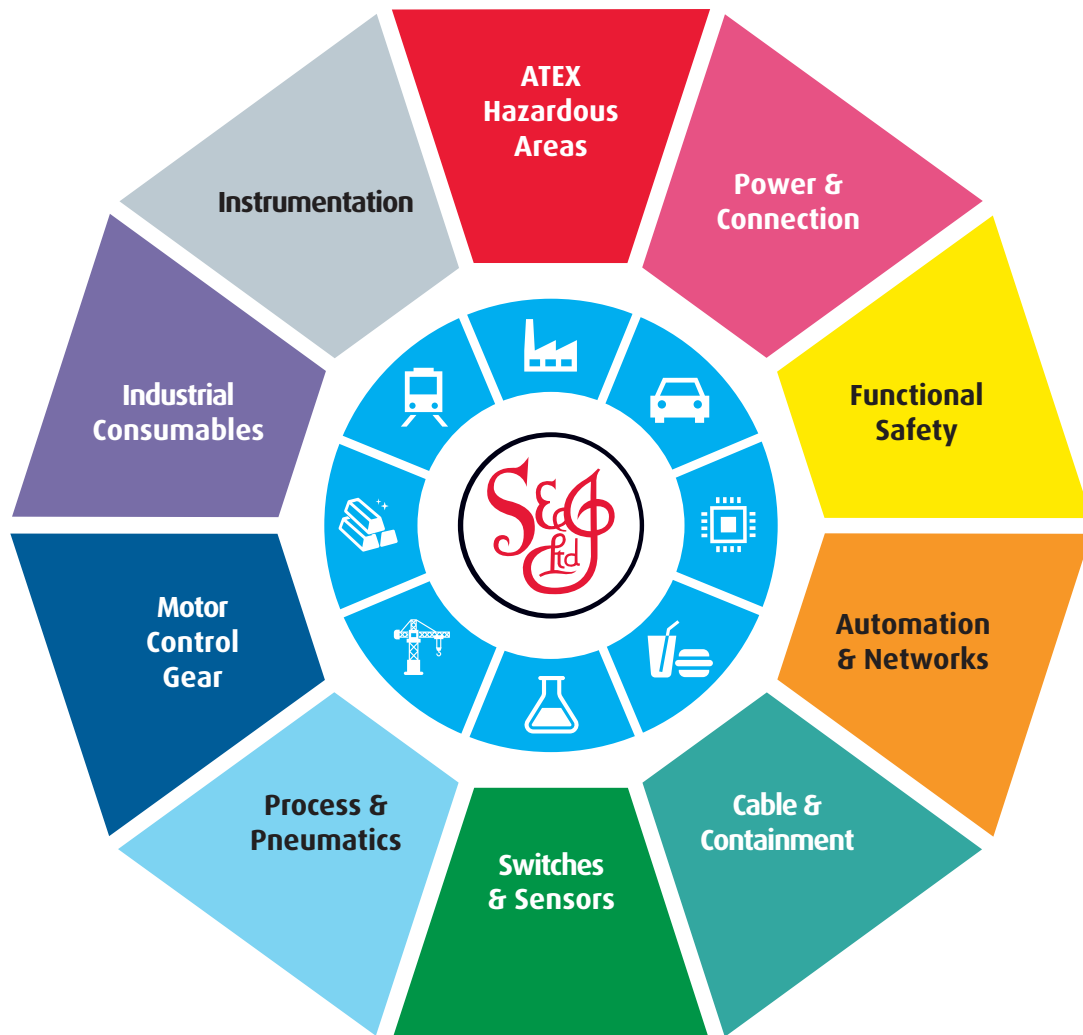

Online, In Branch and On the Road - Scattergood & Johnson Ltd, there when you need us.

www.scatts.co.uk