

3. Operating elements

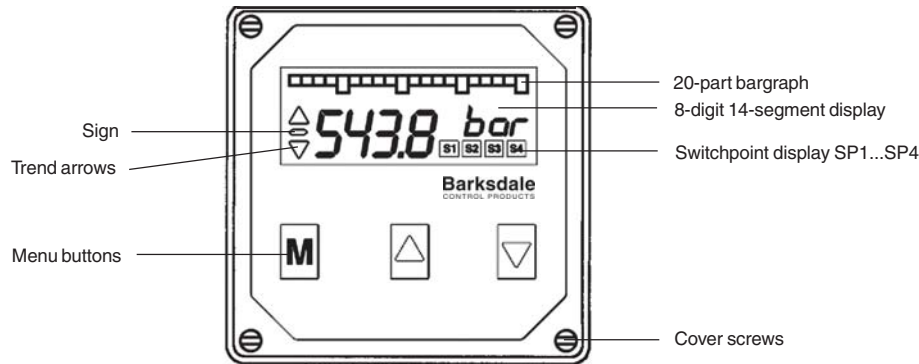

Electrical connection

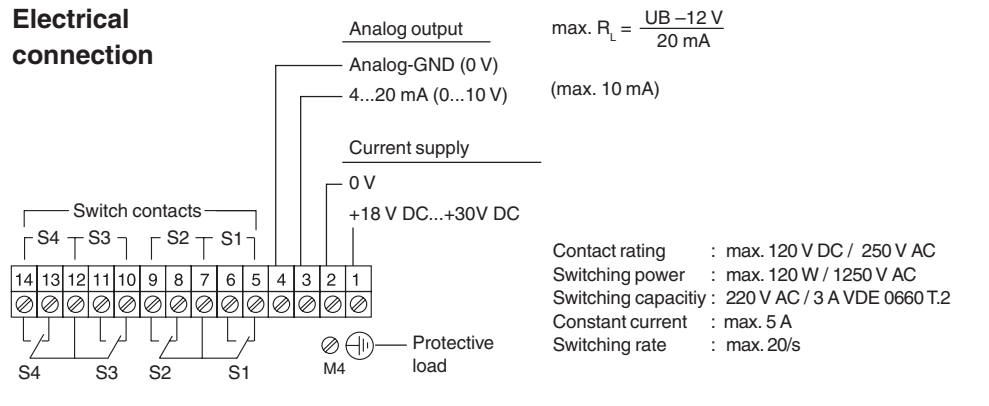

Sensor connection UAS 3

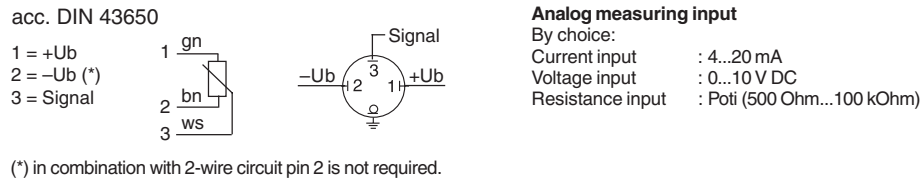

Barksdale

CONTROL PRODUCTS

Barksdale GmbH

Dorn-Assenheimer Strasse 27
D-61203 Reichelsheim / Germany

Tel.: +49 - 60 35 - 9 49-0
Fax: +49 - 60 35 - 9 49-111 and 9 49-113
e-mail: info@barksdale.de
www.barksdale.de

Operating Instructions Pressure Switch UDS 3 with 4 Relay Outputs and Trip Amplifier UAS 3

Dimensions (in mm)

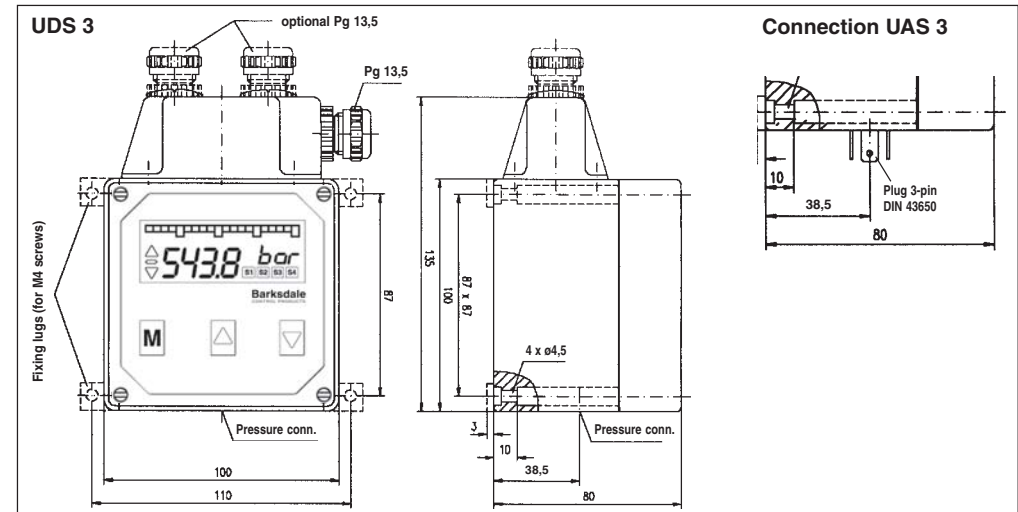

1. Product description

Intended applications

- The pressure switch / trip amplifier is a device to monitor system pressure, temperature, flow, level, etc. and has four switching outputs and one analog output.
- The pressure switch is only to be installed in systems where the maximum pressure Pmax is not exceeded (according to the values on the type label).
- The trip amplifier is only to be connected to input signals according to the values on the type label at the bottom side of the device.
- **Attention:** This device is not designed to be used as the only safety relevant element in pressurized systems according to PED 97/23/EC.

2. Starting operations

Only assemble or disassemble the device when depressurized!

- The pressure switch should be installed and operated only by authorized personnel.
- Front cover and device bottom form a function unit. Exchanging the parts can result in measuring errors or malfunctioning. See serial number inside the front cover. For wall mounting remove the four front cover screws and the front cover. Then fasten the device with four screws to the wall and finally remount the front cover. To damp strong vibrations shock mounts must be used.
- Mount the pressure connection (G 1/4 female) of the UDS 3 to the pressure system with a flexible pipe and tighten with a 45 Nm torque. For pressure peaks damping screws must be used.
- UAS 3: Connect the sensor to the 3-pin cube plug at the bottom side of the device.
- The electrical connection (supply, analog output switching contacts) must be carried out according to the connection tables depicted on the top of the device by removing the cover cap and insert the cable through the cable gland PG 13,5. If required, additional cable glands can be installed in the cover cap by breaking out the perforated cavities.
- The electrical connection must be carried out in accordance with the VDE 0100 regulations. In order to ensure trouble-free operation it is essential to connect the protective lead. When operating from 230 V AC loads at the switch contacts independent cables must be installed for supply and switches (cover cap with two cable screw connections).
- If inductive loads (magnets, contactors, etc.) are connected to the switch relays, suitable protective devices (varistors etc.) must be provided.

List of functions

Main Menu	Sub Menu	Value	Description
Measuring mode		Display of the actually measured value and the measuring unit
MENU		UNLK LOCK	Display keylock No keylock, all parameters can be adjusted Keylock active, all parameters visible but can not be changed
SP.1 ... SP.4	MODE	STND WIND ERRO	Switchpoint menu SP1..SP4 Standard evaluation (rising/falling) Window technology Error output
	ON	Switch-on value for SP1..SP4; if the ON-value is smaller than the OFF-value, the switch evaluation is falling
	OFF	Switch-off value SP1..SP4
	LEV	HLFS LLFS	Inversion of the switching output SP1...SP4 High-level-fail-safe (Normally Open function) Low-level-fail-safe (Normally Closed function)
	DEL	0,0s..9,9 s	Switch-on / switch-off delay for SP1...SP2 in seconds
ANOP	ANOP	ON OFF	Analog output menu Analog output in operation Analog output switched off
	AOZS	Scale the analog output - start value (e.g. 0 bar=4mA)
	AOFS	Scale the analog output - end value (e.g. 400bar=20mA)
DISP	UNIT (only UDS3)	bar PSI MPa :	Display menu Adjustment of the measuring unit, the recalculation to the new unit value is done automatically
	DAMP	0,0s..9,9 s	Damping of the displayed measuring value in seconds
	OFFS	Measuring value -Offset, means shifting the display range
	CUT	Cut-Off, means signal-suppression within the cut-off range
	BGZS	Scale the bargraph - start value
	BGFS	Scale the bargraph - end value
PEAK	MIN CLRM NO YES	Peakholding menu Display the peak value „Min“ no deletion delete „Min“-value
	MAX CLR NO YES	Display the peak value „Max“ no deletion delete „Max“-value
CAL (only UAS3)	DECP ZSCL FSCL UNIT	0000..0,000 bar PSI :	Calibration menu Declaration of the decimal-point for the measuring value Scale the measuring-value indication - start value Scale the measuring-value indication - end value Declaration of the measuring unit
	UTXT CODE	TEXT ABCD	Enables the indication of the measuring-unit which is defined in the UTXT menu Programm a free configurable text for the measuring unit Calibration menu for the manufacturer

4. Operation

After the unit is switched on, the unit starts an automatic self-test.
The device is menu operated and configured by the three keys on the front.
With the „M“ key (= mode) you change between the operation / indicating level to the dialog values and the adjusted / actual values. With the keys („↑“ = up) and („↓“ = down) you change between the dialog values in the menu or change the values / functions in the menus.
A change of any configuration starts always with the M-Mode and indicated by the flashing cursor. After a change has been made the M-mode key must be pressed to confirm each configuration; to set numbers, each digit has to be confirmed with the M-Mode before adjusting the next one. By confirming the last digit the new configuration will be stored in the memory.
Pushing the down key at the end of the sub-menu the software will switch automatically to the main-menu.

For a quick termination of programming you can change into the measuring mode from any level in the menu by pressing the M-key for 5 seconds.

If the dialog is not continued within two minutes the device automatically returns to the measuring mode without accepting the new values (see also: „List of functions“).

5. Key lock

Activating the („↑“ = up) and („↓“ = down) keys together for more than 5 seconds will block any changings in all menus; shown by „LOCK“ in the display.
In this mode, all configuration values can be checked only, but not changed.

Repeating this action will unlock the configuration menu and shown by „UNLK“ in the display.

6. Error handling

The internal self-check software will monitor the proper functioning of the unit. When any of the following failures will occur, the flashing display will indicate the following text:

Display	Error	Cause
max	Positive excess of the measuring range	The measured value exceeds the max. of the range
min	Negative excess of the measuring range	The measured value is lower than the min. of the range
anao	Failure of the analog output	Output loop is not closed or short circuited
sens	Sensor failure (internal)	Sensor bridge not in balance, might be been overloade
data	Stored data failure (EEProm) (internal)	Memory failure
prog	Processor failure (internal)	Microcontroller failure
cal	Calibration failure (internal)	Calibration values are wrong

Measuring mode

Menu Structure UDS 3

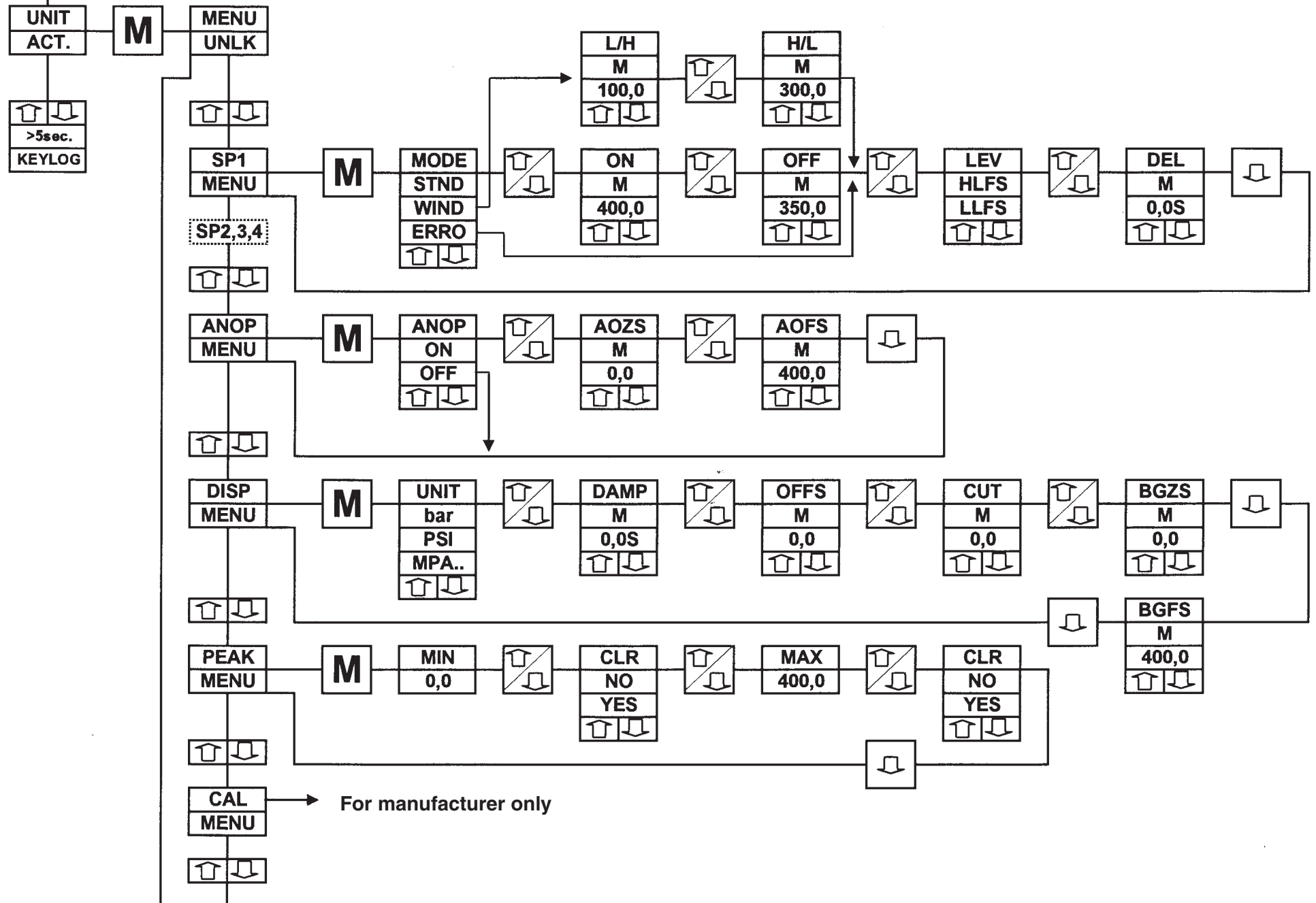

Measuring mode

Menu Structure UAS 3

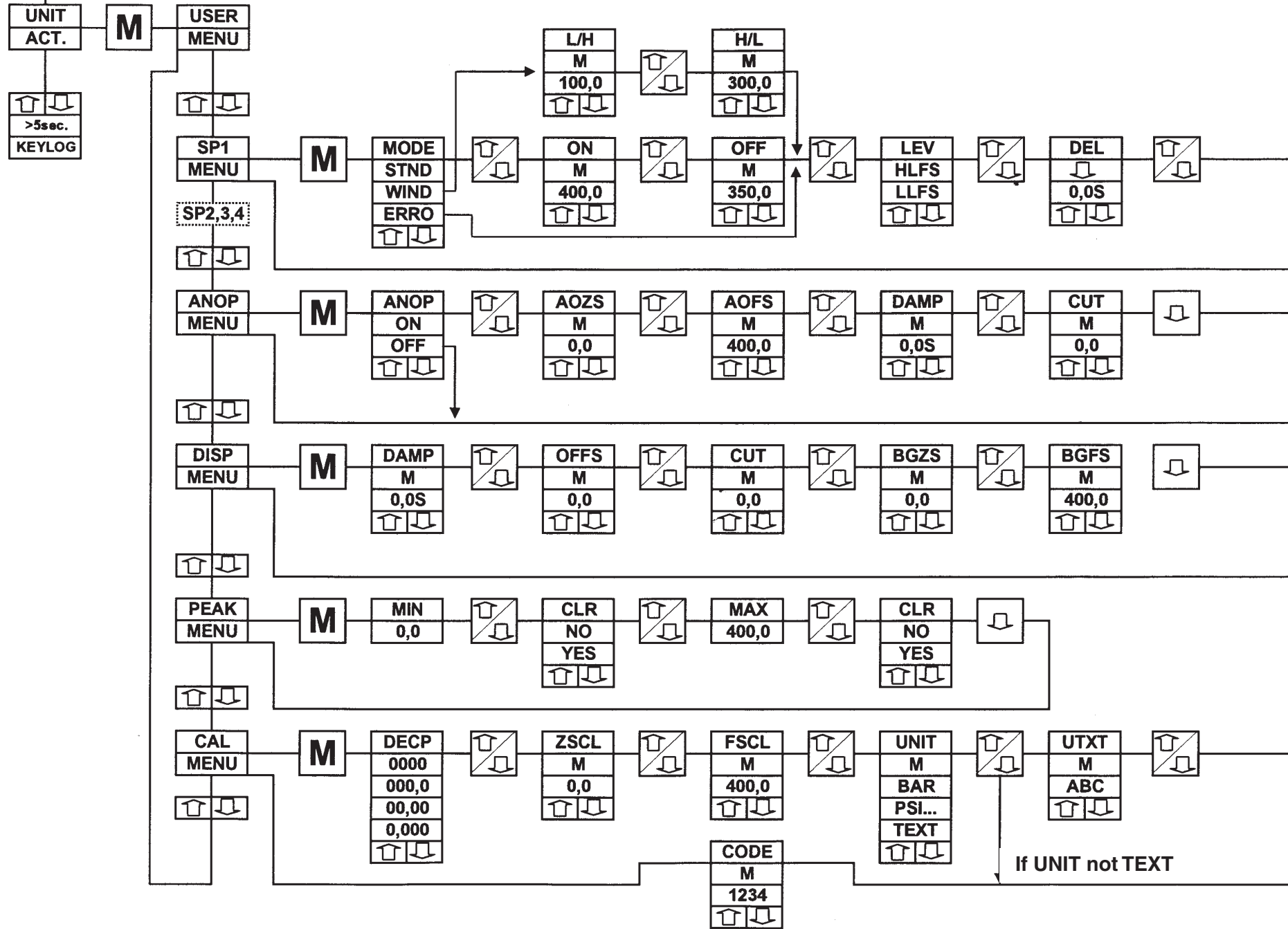



**SCATTERGOOD
& JOHNSON LTD**
ELECTRICAL ENGINEERING & FLUID CONTROL DISTRIBUTORS

Est.1899

At Scattergood & Johnson Ltd, we pride ourselves on being a technical distributor to specialist industries.

Working with a range of quality product manufacturers across a number of specialist markets, we are not your average 'box shifter' - we are your technical and supply chain partner.

We fully support every product we sell - for free! Our internal team and external sales engineers can answer any product or application question, no matter the complexity.

Backing up this technical ability is a range of 50,000+ products available from stock for nationwide next day delivery (same day if required!), or you can collect what you need from any of our trade counters around the UK.

Select your specialist interest below to learn more about how we can help.



Online, In Branch and On the Road - Scattergood & Johnson Ltd, there when you need us.

www.scatts.co.uk