

ADJUSTING INSTRUCTIONS (Continued)

PK 81028

Direction of Actuation

Operation in clockwise, counterclockwise or both directions of the lever arm is possible. As factory assembled, the switch is actuated in both directions. To convert the switch to one direction actuation, remove the actuator head and rotate the step plunger 90° clockwise or counterclockwise. When the switch is adjusted for actuation in one direction only the arm may be moved to the full overtravel position in the opposite direction without damaging the mechanism.

NOTICE

If the actuator head is removed and replaced, readjustment for operating characteristics may be necessary. See Adjusting Operating Characteristics.

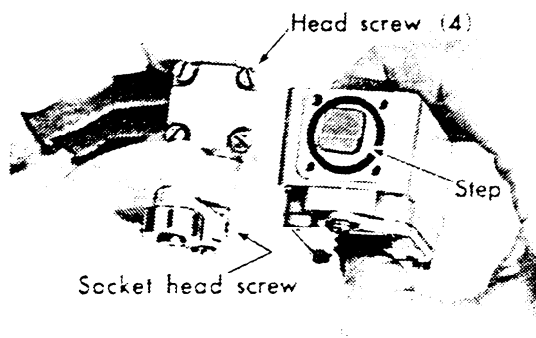

Adjusting Operating Point

Rotary Actuator Types (1LS and 201LS)

Top In-Line Actuator Types 2LS, 5LS, 202LS, 205LS

When replacement of the contact block is necessary or if the actuator head is removed and replaced, readjustment may be required to duplicate the operating point as originally provided in the factory assembled switch. This adjustment is made after the contact block has been secured to the housing and with the external lever arm or in-line plunger in the free position. Using a 3/16-inch wrench, turn the adjusting screw two turns clockwise (two wrenches are needed for top in-line plunger switches). Insert a .045 to .049 inch feeler gage between adjusting screw and internal switch plunger. Turn adjusting screw counter-clockwise until contact block operates. See "Handy Adjusting Tool Set" 15PA53.

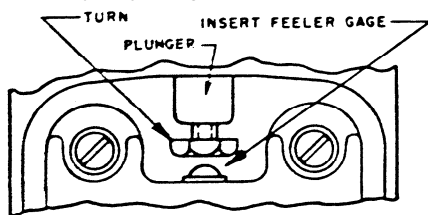

Adjusting Flexible Type Actuator "LS" Switches (8LS and 208LS)

Use two 3/16-inch open end wrenches to hold plunger and turn adjusting screw two turns clockwise. Insert a .025 to .030 inch feeler gage between adjusting screw and button on contact block. Turn adjusting screw counterclockwise until contact block operates.

Adjusting Side Actuated "LS" Switches (3LS, 4LS, 203LS, and 204LS)

Hold the actuating plunger in fully depressed position and with a 3/16-inch wrench, turn the adjusting screw counterclockwise until the switch "clicks". Then continue to turn the screw another ¼ turn to provide the necessary overtravel.

CAUTION: Be certain not to turn the adjusting screw more than ¼ turn beyond the operating point. It could exceed the overtravel of the basic switch and cause permanent damage to the contact block.

Adjusting Yoke Type Actuated "LS" Switches (6LS and 206LS)

Remove the switch cover plate (or entire switch in the 206LS1 "Plug-in" design) to expose the internal actuating plunger and the contact block. Using the screwdriver slot on the end of the shaft as a guide, adjust internal plunger set screw so that the basic switch operates and releases at approximately equal angles past the vertical line on the screwdriver slot. Adjust in both the counterclockwise and the clockwise directions.

Be certain not to turn the adjusting screw too far out, so that it would exceed the overtravel of the contact block and cause permanent damage to the contact block.

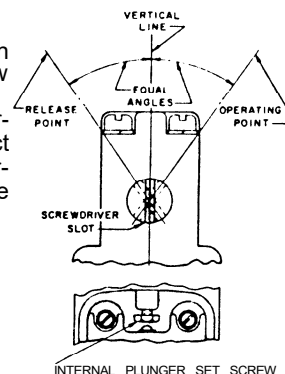

Short Pretravel Switches

Adjusting instructions and figure below apply to the short pretravel switches 1LS19, 1LS27, 1LS47, 1LS56, 1LS58, and 1LS59.

Using a 3/16-inch wrench, turn adjusting screw two turns to the right. Insert .008-inch feeler gage between adjusting screw and top lever. Turn adjusting screw to the left until basic switch clicks.

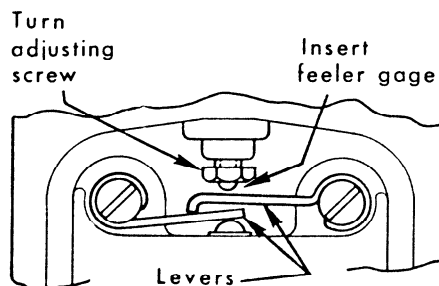

Contact Block Replacement

Remove cover plate (or entire switch assembly of "Plug-in" design) and remove the plastic contact block. Turn internal plunger adjusting screw two full turns to the right. Mount new block.

The Handy Adjusting Tool Set for all adjustments on type "LS" switches contains (2) 3/16-inch open-end wrenches, (1) 5/32-inch hexagon key wrench, Order Packet Number 15PA53.

REPLACEMENT PARTS

PK 81028

Packet A -

Complete head and lever assembly includes: Lever arm, actuator housing, return spring, actuator plunger sleeve, shaft and seal-ring and housing retaining screws.

Packet B -

Lever arm assembly (includes set screw).

Packet C -

Contact Block Replacement (includes housing cover, housing seal cover, cover mounting screws, and contact block mounting screws.)

Packet D -
Plunger Assembly Replacement (includes adjusting screw and seal ring).

*Packets do not include lever arm "B"

* *Refer to page 4 for choice of actuator packet numbers that fit switch

** *Packet A does not include Plunger Assembly, which must be ordered separately as indicated in Packet D Column.

† This actuator is NOT interchangeable with same actuator design without boot seal

Note 1:
For switches with code number 6732 and higher, use 8PA50.
For switches with code number 6731 and lower use 8PA11.

(Code number appears on nameplate to the left of the catalog listing.)

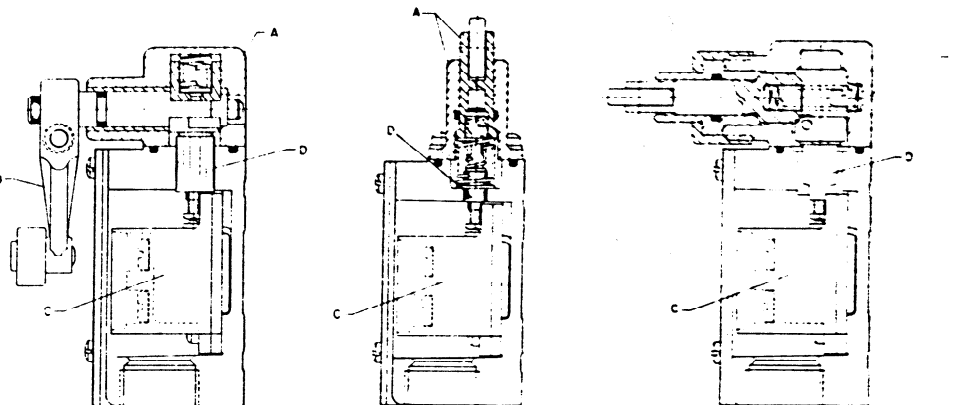

1LS, 6LS, 201LS, 206LS

2LS, 5LS, 202LS, 205LS

3LS, 4LS, 203LS, 204LS

SWITCH LISTING	FEATURE	PACKET A Head*** Assembly	PACKET B** Lever Assembly	PACKET C Contact Block	PACKET D Plunger Assembly
COMPACT TYPE					
1LS1	Std., pretravel 20°	9PA15	1	2MN1	8PA11
1LS2	20° pretravel 4½ in.-lbs. force	9PA16*	1, 2, 3, 4, 5, 6	2MN1	8PA11
1LS3	Adjustable reversible lever	9PA16*	2	2MN1	8PA11
1LS6	Light force	9PA50	1	2MN1	8PA11
1LS9	5° pretravel	9PA16*	1, 2, 3, 4, 5, 6	2MN8	Note 1
1LS10	5 in. aluminum rod-adjustable	9PA40	3	2MN1	8PA11
1LS19	Std., pretravel 5°	9PA15	1	2MN8	Note 1
1LS23	Low force 20° pretravel	9PA68*	1,3,4	2MN1	8PA11
1LS27	5 pretravel 4½ in.-lbs force	9PA16*	1,2,3,4,5,6	2MN8	Note 1
1LS47	5 in. aluminum rod adjustable 5° pretravel	9PA40	3	2MN8	Note 1
1LS53	Light force	9PA48	3	2MN8	Note 1
1LS56	Low force 5° pretravel	9PA74*	1,3,4	2MN8	Note 1
1LS58	Adjustable reversible lever 5° pretravel	9PA16*	2	2MN8	Note 1
1LS59	Adjustable reversible lever 18 oz. force	9PA68*	2	2MN8	Note 1
1LS128	1½ in. dia. MDN roller	9PA16*	2 (6PA67)	2MN1	8PA11
1LS243	Hi temp. +250° F	9PA55	1 (6PA121)	2MN1	8PA50
1LS501	Lighted Indicator in nameplate - 120 VAC	9PA15	1	2MN1	8PA11
2LS1	Top actuated plunger	9PA32	N/A	2MN1	8PA58
3LS1	Side actuated plunger	9PA45	N/A	2MN11	8PA43
4LS1	Side actuated plunger	9PA44	N/A	2MN11	8PA43
5LS1	Top actuated roller plunger	9PA33	N/A	2MN1	8PA58
5LS7	Top actuated roller plunger, rotated 90° Boot Seal	9PA79†	N/A	2MN1	8PA57
5LS8	Top actuated roller plunger, with boot seal	9PA79†	N/A	2MN1	8PA57
6LS1	Maintained contact - supplied with lever 6PAS0	9PA46	7 (6PA80)	2MN1	8PA59
6LS2	Maintained contact - see Packet B for lever	9PA47*	7	2MN1	8PA59
6LS3	Rollers on same side of yoke arm	9PA47*	7 (6PA102)	2MN1	8PA59
7LS1	Flush panel mount	9PA15	1	2MN1	8PA11
8LS1	Cable type actuator	9PA58	N/A	2MN11	N/A
8LS3	Coil spring with rod	9PA49	N/A	2MN1	N/A
8LS125	Music wire actuator	9PA54	N/A	2MN11	N/A
8LS152	Coil spring actuator	9PA42	N/A	2MN1	N/A
11LS1	Four-circuit double-break (solder terminals)	9PA15	1	8AS42	8PA11
PLUG-IN TYPE (Use with terminal block 18PA1)					
201LS1	20° pretravel	9PA15	1	2MN6	8PA11
201LS1-NA	Pretravel 20°, nylon roller, clockwise operator	9PA16*	1 (6PA71)	2MN6-A	8PA11
201LS2	20° pretravel 4½ in.-lbs.	9PA16*	1, 2, 3, 4, 5, 6	2MN6	8PA11
201LS3	Reversible adjustable lever	9PA16*	2	2MN6	8PA11
201LS6	Light force 18 oz.	9PA50	1	2MN6	8PA11
201LS9	5° pretravel 3lbs. force	9PA16*	1, 2, 3, 4, 5, 6	2MN13	Note 1
201LS10	5 in. aluminum rod - adjustable	9PA40	3	2MN6	8PA11
201LS19	5° pretravel	9PA15	1	2MN13	8PA11
201LS23	Low force 20° pretravel	9PA68*	1,3,4	2MN6	Note 1
201LS47	5 in. aluminum rod adjustable 5° pretravel	9PA40	3	2MN13	8PA11
201LS56	Low force 5° pretravel	9PA74*	1,3,4	2MN13	Note 1
201LS242	Hi temp. +250° F	9PA55	1 (6PA121)	2MN6	8PA50
201LS501	Light indicator in name plate - 120 VAC	9PA15	1	2MN14	8PA11
202LS1	Top actuated plunger	9PA32	N/A	2MN6	8PA58
202LS7	Top actuated plunger with Boot Seal	9PA78†	N/A	2MN6	8PA57
203LS1	Side actuated roller plunger	9PA45	N/A	2MN8	9PA43
204LS1	Side actuated plunger	9PA44	N/A	2MN9	8PA43
205LS1	Top actuated roller plunger	9PA33	N/A	2MN6	8PA58
205LS7	Top actuated roller plunger Rotated 90° Boot Seal	9PA79†	N/A	2MN6	8PA57
205LS8	Top actuated roller plunger with Boot Seal	9PA79†	N/A	2MN6	8PA57
206LS1	Maintained contact - supplied with lever 6PAS0	9PA46	7(6PA80)	2MN6	8PA59
206LS2	Maintained contact - see Packet B for Lever	9PA47	7	2MN6	8PA59
208LS1	Cable type actuator	9PA58	N/A	2MN9	N/A
208LS3	Coil spring with rod	9PA49	N/A	2MN6	N/A
208LS125	Music wire actuator	9PA54	N/A	2MN9	N/A
208LS152	Coil spring actuator	9PA42	N/A	2MN6	N/A

HONEYWELL

TYPES OF ACTUATORS

PK 81028

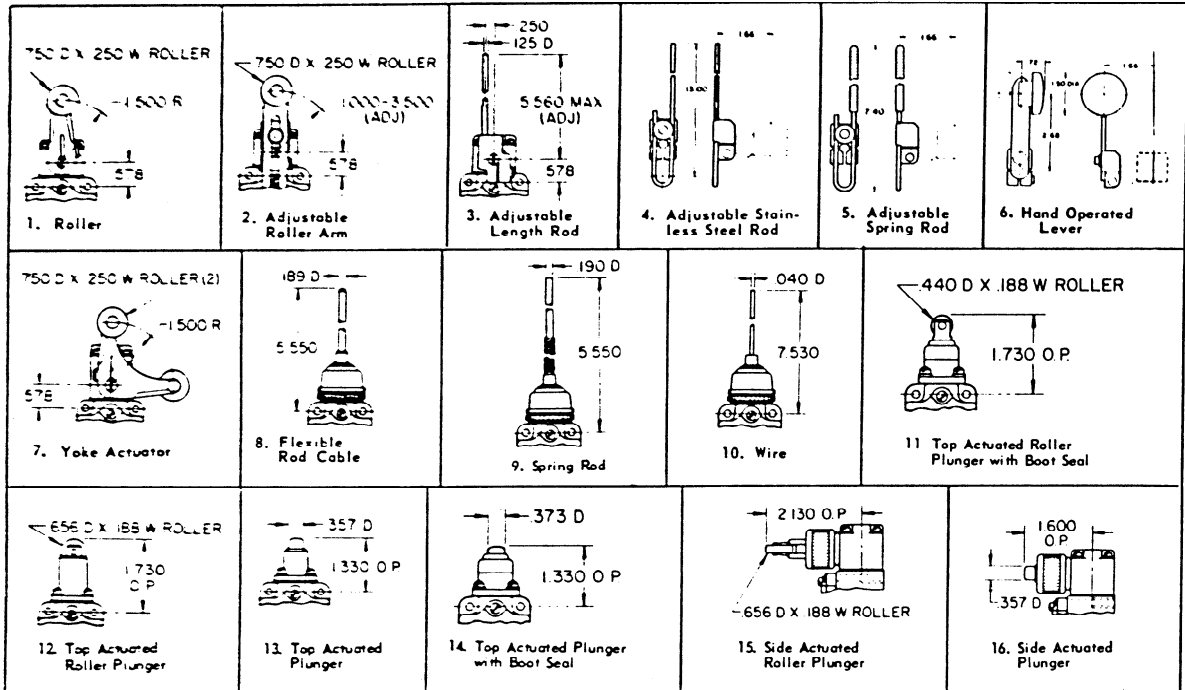

See Table below for variations and ordering numbers.

Actuator Type No.	Roller Diameter	Roller Thickness	Roller Material	Lever or Rod Length	Rod Diameter	Adjustable Lever or Rod	Rod Material	Rollers Same Side	Rollers on Ea. Side	Order Actuator Packet No.
1	0.750 0.750 0.750	0.250 0.250 0.280	MDN† Steel Steel††							6PA71 6PA121 6PA144
2	0.750 0.750 1.000 1.500 2.000	0.250 0.250 0.500 0.250 0.250	MDN Steel MDN MDN MDN	3.5 3.5 3.5 3.5 3.5		x x x x x				6PA44 6PA56 6PA68 6PA67 6PA64
3				5.0	0.125	x	Aluminum			6PA43
4				12.0		x	Stainless Steel			6PA63
5				7.5		x	Stainless Steel			6PA69
6	1.500 (Button Dia.)			2.68						6PA57
7	0.750 0.750 0.750 0.750	0.250 0.250 0.250 0.250	Steel MDN Steel MDN					x x		6PA82 6PA102 6PA80 6PA119
8	Cable Type			5.55	0.189					9PA58*
9	Coil Spring Actuator			5.55	0.264					9PA42*
9	Coil Spring with Rod			5.55	0.264					9PA49*
10	Music Wire Actuator			7.53	0.040					9PA54*
11	0.440	0.188	Steel				with Boot Seal			9PA79**
12	0.656	0.188	Steel							9PA33*
13	Top Actuated Plunger									9PA32*
14	Top Actuated Plunger with Boot Seal									9PA78**
15	0.656	0.188	Steel							9PA45*
16	Side Actuated Plunger									9PA44*

† High Strength Nylon Roller
 †† With Ball Bearings
 Measurements in Inches.

* Order complete head assembly. Actuator not sold separately
 ** This actuator is NOT interchangeable with the same actuator design without boot seal.



**SCATTERGOOD
& JOHNSON LTD**
ELECTRICAL ENGINEERING & FLUID CONTROL DISTRIBUTORS

Est.1899

At Scattergood & Johnson Ltd, we pride ourselves on being a technical distributor to specialist industries.

Working with a range of quality product manufacturers across a number of specialist markets, we are not your average 'box shifter' - we are your technical and supply chain partner.

We fully support every product we sell - for free! Our internal team and external sales engineers can answer any product or application question, no matter the complexity.

Backing up this technical ability is a range of 50,000+ products available from stock for nationwide next day delivery (same day if required!), or you can collect what you need from any of our trade counters around the UK.

Select your specialist interest below to learn more about how we can help.



Online, In Branch and On the Road - Scattergood & Johnson Ltd, there when you need us.

www.scatts.co.uk