

zipper | e-tubes | Series R15 | Delivery program

Fast opening, enclosed zipper-band

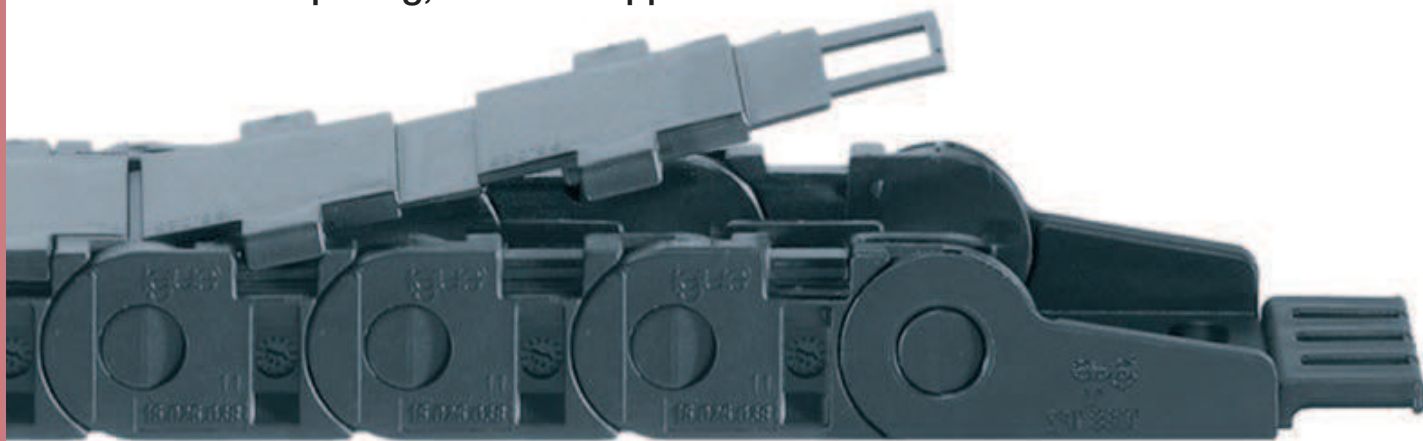
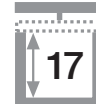

e-tube | Series R15 | Zip-open along outer radius

| e-tube zip-open along outer radius | <i>Bi</i> [mm] | <i>Ba</i> [mm] | <i>R</i> Bending radii [mm] | Weight [kg/m] |
|------------------------------------|-------------------|-------------------|---|------------------|
| R15. 015 .R.0* | 15 | 26 | 063 075 100 110 125 145 180 | ≈ 0,40 |
| R15. 025 .R.0 | 25 | 36 | 063 075 100 110 125 145 180 | ≈ 0,45 |
| R15. 038 .R.0 | 38 | 49 | 063 075 100 110 125 145 180 | ≈ 0,51 |
| R15. 050 .R.0* | 50 | 61 | 063 075 100 110 125 145 180 | ≈ 0,57 |
| R15. 063 .R.0 | 63 | 76 | 063 075 100 110 125 145 180 | ≈ 0,68 |
| R15. 080 .R.0 | 80 | 94 | 063 075 100 110 125 145 180 | ≈ 0,75 |
| R15. 100 .R.0* | 100 | 113 | 063 075 100 110 125 145 180 | ≈ 0,81 |

Before using this Series on long travels please consult igus®.

Supplement Part No. with required radius (*R*). Example: R15.025.063.0

Dimensions

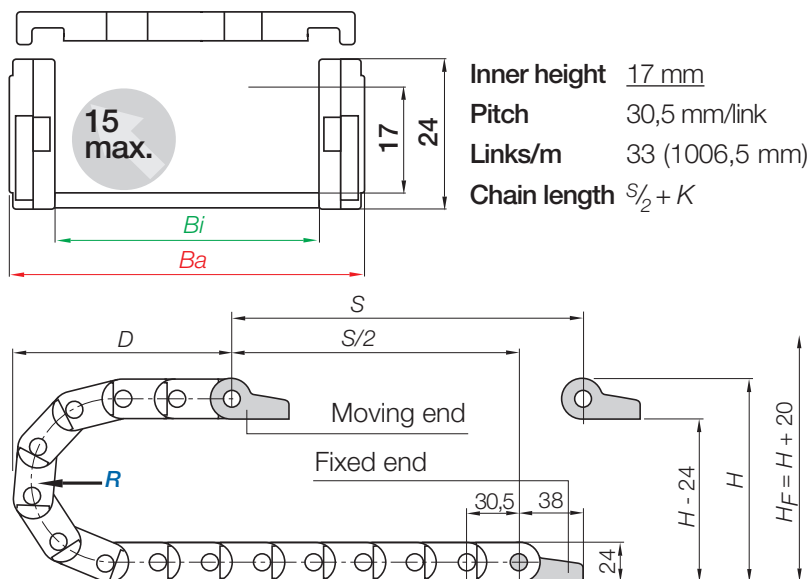
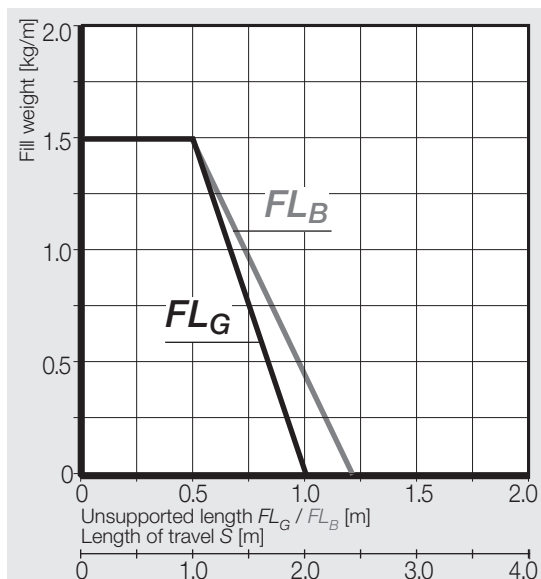

| | | | | | | | |
|----------|-----|-----|-----|-----|-----|-----|-----|
| <i>R</i> | 063 | 075 | 100 | 110 | 125 | 145 | 180 |
| <i>H</i> | 149 | 173 | 223 | 243 | 273 | 313 | 383 |
| <i>D</i> | 120 | 132 | 157 | 167 | 182 | 202 | 237 |
| <i>K</i> | 260 | 300 | 380 | 410 | 455 | 520 | 630 |

The required clearance height: $H_F = H + 20$ mm (with 1,0 kg/m fill weight)

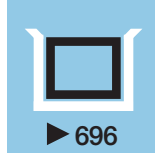

Mounting brackets, polymer one-piece | pivoting | locking

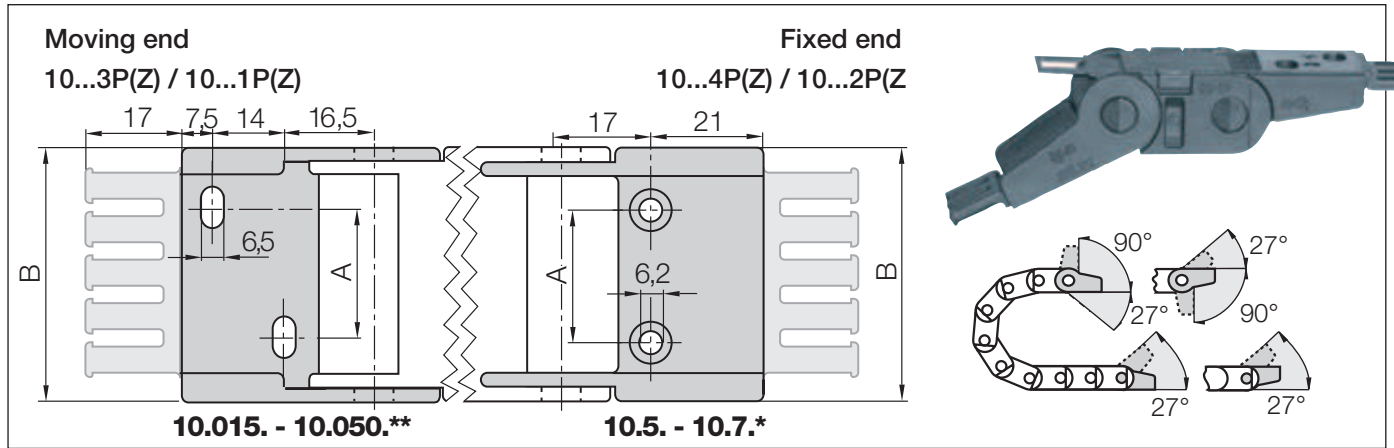

| Width Index | Standard | Part No. full set pivoting: | | Part No. full set locking: | | Dim. A [mm] | Dim. B [mm] | Number of teeth |
|-------------|----------|-----------------------------|------------------------|----------------------------|------------------------|-------------|-------------|-----------------|
| | | with tiewrap plates | without tiewrap plates | with tiewrap plates | without tiewrap plates | | | |
| 015. | ▶ | 1015.34PZ | 1015.34P | 1015.12PZ | 1015.12P | – | 25,5 | 2 |
| 025. | ▶ | 1025.34PZ | 1025.34P | 1025.12PZ | 1025.12P | 10 | 35,5 | 3 |
| 038. | ▶ | 1038.34PZ | 1038.34P | 1038.12PZ | 1038.12P | 23 | 48,5 | 4 |
| 050. | ▶ | 1050.34PZ | 1050.34P | 1050.12PZ | 1050.12P | 35 | 60,5 | 5 |
| 5. | ▶ | 105. 34PZ | 105. 34P | 105. 12PZ | 105. 12P | 48 | 75,0 | 6 |
| 6. | ▶ | 106. 34PZ | 106. 34P | 106. 12PZ | 106. 12P | 65 | 92,0 | 8 |
| 7. | ▶ | 107. 34PZ | 107. 34P | 107. 12PZ | 107. 12P | 85 | 112,0 | 10 |

** Drilling pattern for width index: 15.015. - 15.050. see drawing left. Each valid for Moving end and Fixed end

* Drilling pattern for width index: 15.5 - 15.7. see drawing right. Each valid for Moving end and Fixed end

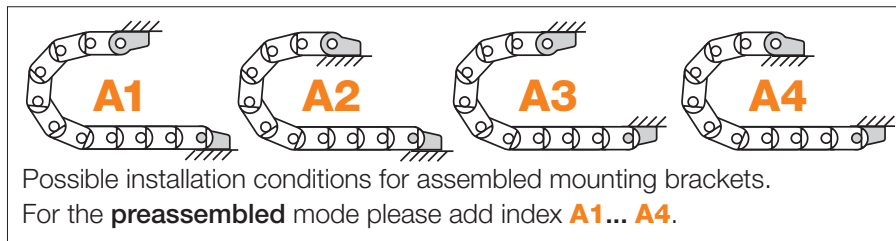

Part No. structure

1025. 34 PZ A1

- A... must be indicated on preassembled configurations
- With strain relief tiewrap plates
- Full set pivoting**
- Mounting bracket for selected width index

Interior separation

Slotted separator for e-tubes

unassembled **R153**
assembled **R154**

Slotted separator R153

Is used when vertical separation is required. Due to its slot, it allows basic vertical/horizontal shelving arrangements.

Full-width shelf for e-tubes

unassembled **110.X**
assembled **111.X**

Full-width shelf 110.X

This option makes sense in applications with many thin cables with similar diameters. For a consequent subdivision. Full-width shelves can be arranged at 3 different heights (in 5 mm increments).

Full-width shelves

| Width X [mm] | unassembled | assembled | Width X [mm] | unassembled | assembled |
|--------------|-------------|-----------|--------------|-------------|-----------|
| 025 | 110.25 | 111.25 | 063 | 110.63 | 111.63 |
| 038 | 110.38 | 111.38 | 080 | 110.80 | 111.80 |



**SCATTERGOOD
& JOHNSON LTD**
ELECTRICAL ENGINEERING & FLUID CONTROL DISTRIBUTORS

Est.1899

At Scattergood & Johnson Ltd, we pride ourselves on being a technical distributor to specialist industries.

Working with a range of quality product manufacturers across a number of specialist markets, we are not your average 'box shifter' - we are your technical and supply chain partner.

We fully support every product we sell - for free! Our internal team and external sales engineers can answer any product or application question, no matter the complexity.

Backing up this technical ability is a range of 50,000+ products available from stock for nationwide next day delivery (same day if required!), or you can collect what you need from any of our trade counters around the UK.

Select your specialist interest below to learn more about how we can help.



Online, In Branch and On the Road - Scattergood & Johnson Ltd, there when you need us.

www.scatts.co.uk