



SafeSite® Emergency Stainless Steel Linear for ATEX/IECEX

Important Information:

These instructions contain safety information, read and follow them carefully. Dialight will not accept any responsibility for injury, damage or loss which may occur due to incorrect installation, operation or maintenance.

Operating Instructions



Note: Save these instructions for future use

9100127275599 REV B
 Dialight, 1501 Route 34 South, Farmingdale, NJ, USA 07727
 Tel: 732 919 3119 Fax: 732 751 5778 www.dialight.com



Safety Instruction:

The installation, operation and maintenance must be carried out by an electrician suitably trained in hazardous areas with knowledge of increased safety explosion protection IEC 60079-14.

- The technical data indicated on the LED luminaires are to be observed.
- Changes of the design and modifications to the LED luminaire are not permitted.
- Observe the national electrical safety rules and regulations during installation.
- No user serviceable parts inside.
- Only the battery pack is replaceable.

Technical Data:**Category of Application:**

35W:	Ex e mb IIC T4 Gb Ex tb IIIC T135°C Db ⊕ II 2GD
70W	Ex e mb IIC T4 Gb Ex tb IIIC T135°C Db ⊕ II 2GD
IECEx / ATEX:	SIRA 12ATEX3217X / IECEx SIR 12.0093X
Rated Input Voltage:	230/240 VAC 50/60 Hz
Rated Input Current:	
35W:	150mA at 230V AC
70W:	300mA at 230V AC
Inrush Current @230VAC	
35W:	4A for 50µs
70W:	1.6A for 0.5ms
Operating Temp.	-20°C to +60°C
Housing:	Marine Grade 316 Stainless Steel IP66/67
Dimensions:	See diagram page
Cable Entries:	Standard 2 OFF M20 x 1.5mm both ends (Other entry options)
Terminal block:	Standard: 4-way, max. 4mm ² 3-Phase: 7-way, max. 4mm ²
Through cable:	Standard: 3 x 1,5 mm ² 3-Phase: 7 x 2,5mm ²
Tightening Torques:	See diagram page
Weight:	
35W:	8.9Kg
70W	13.7Kg
Battery Capacity:	10Ah 3.6VDC NiMH

Conformity with Standards

This equipment conforms to the standards specified in the Declaration of Conformity. It has been designed, manufactured and tested in accordance with BS EN 9001.

Atex Directive 2014/34/EU: Equipment and protective systems intended for use in potentially explosive atmospheres. EMC Directive 2014/30/EU for electromagnetic compatibility.

Equipment Application

This lighting equipment is intended for use in a potentially explosive atmosphere in Zones 1 and 2 to the requirements of ATEX Directive 2014/34/EU. The product can be used inside or outside to illuminate areas with a potentially explosive atmosphere.

Mounting the Luminaire

Assemble the mounting bracket to the luminaire with 2 off M8 x 1.25 by 16mm bolts. Torque specification: 2.0 Nm maximum.

Installation

Ensure that the mains voltage supply is disconnected before connecting the luminaire. Install the equipment in accordance with the manufacturer's instructions as well as any other applicable electrical codes.

Always transport and store the equipment in its original packaging and keep in a dry location.

When unpacking check for any cracks or damage in the housing, end covers and lens. If in doubt, do not install!

All ELA and ELEA luminaires come complete with through wire capabilities and as such, the mains can enter the luminaire from either end. All ELA and ELEA luminaires come with two entry points at each end to allow for mains in, switched live in and through wires out on separate cables if required.

Opening the Terminal Tray

To open the tray, completely remove the two 4mm HEX socket screws at either the emergency module end or the luminaire end. Once these are removed, the tray can be slid out exposing the terminal block.

The terminal blocks are mounted to the front sides of the trays (where the front side is the light output side) This gives easy access to the terminals when the luminaire is mounted in position.

The terminal tray is captive and will not fall out when slid open to its maximum position.

The terminal tray slides back into position once the wires are connected to the terminal block (See Electrical connection Section 2). The gear tray should be slid back with care ensuring no cables or wires are overstressed or trapped.

When replacing the end covers, ensure the seals are clean and undamaged. If the covers are not fully in place the screws may be difficult to engage and can be cross-threaded. Do not allow any cables to be trapped by the end covers or terminal tray. Ensure that all wires are clear from the screw entry points.

NOTE: The cable glands used with this fixture must be certified to the Ex e requirements.

Cable gland with O-ring min. thread length C = 10mm.
P = M20 x 1.5mm
P = M25 x 1.5mm (suffix 4)

NOTE: The cable used must be suitable for the site application and/or the site requirements.

When assembling the cable entries for the mains connection, always observe the manufacturer's specifications for the glands used. Unused cable entries must be closed and sealed by a certified blanking plug.

NOTE: Unused cable entries must be closed off with a certified blanking plug or stopper. Dust caps must be removed and replaced with either a suitable cable gland or certified blanking plug.

The cable entries should be securely tightened to ensure that the minimum protection rating is achieved. A locknut is required for each cable gland to securely hold the cable gland to the end covers. The cable entry should be rated to a minimum of IP66/67 to maintain the protection level of the luminaire.

WARNING:

Do not over tighten as the protection rating may be compromised. Always refer to gland manufacturers data for torque settings.

Electrical Connections

The terminal block is suitable for multi-stranded and single core cables up to a maximum of 4mm², strip length 10mm

The LIVE 1, LIVE 2, NEUTRAL and EARTH connections are clearly marked on the terminal block or label.

When connecting the conductors, extra care should be taken in order to maintain the hazardous protection. The insulation of the conductors shall reach up to the terminal block. The conductor itself shall not be damaged. The connectable minimum and maximum conductor cross sections shall be observed (see electrical connection data).

The L1 connection is a permanent live feed. It powers the main normal mode operation, battery charger and is used to activate emergency mode. The L2 connection is a switched live feed to control luminaire normal mode on or off. It is a signal input that consumes negligible current.

Single Luminaire Electrical Connections

Push down at the 'cross point' on the terminal block, insert correct cable and release, ensuring the cable has been securely retained.

Loop Through Electrical Connections

Connect incoming cable as above then connect the outgoing cable to the associated adjoining connection to pass to the next luminaire.

3 Phase Connection

Connect the designated load phase (e.g. L1) to L on the terminal block and the other 2 phases for loop thru L2 / L3 respectively to the terminal block as shown in the diagram

WARNING:

Only single cables to be used on each terminal entry point.

The improper installation, operation, and/or maintenance of these luminaires may result in the invalidation of the warranty.

Use the dimensions in Section 1 provided to locate the luminaire into the desired position. Maximum screw / bolt size M8 x 16 (screws supplied with mounting hardware supplied separately).





Battery

A 3.6V 10Ah (part ref ELX-BATT-KIT) is provided with both the 35W and 70W versions. The 10Ah battery is mounted on a completely removable tray which only requires removing when battery pack replacement is required.

To remove the battery tray, DISCONNECT the 2-pole battery connector and remove the cable tie wrap then loosen battery retaining tray screw. The screw is retained to the tray. Un-hook the tray to remove the battery pack. A new tie wrap may be used to keep the wiring free from chaffing when closing the luminaire.

Battery and Micro-switch Interlock

The driver electronics along with the micro-switch interlock shut down all battery related circuits when the battery end cover is withdrawn.

Closing the LED Luminaire

Remove any foreign bodies from the fixture. Pay attention when closing the terminal tray fitting to the enclosure; make sure the seals are clean and undamaged.

Do not allow any cables to become trapped between the end cover and the enclosure.

Tighten both 4mm HEX socket screws evenly (1.9 Nm)

Taking into Operation

Prior to operating, check the luminaire for its correct installation in compliance with these operating instructions and other applicable regulations.

Attention: Only fully certified equipment may be put into operation.

Improper installation and operation of this luminaire may invalidate the warranty.

Upon applying power, confirm the operation of battery circuits by observing the green status LED located at the end of the led strip. The green status LED will light only if:

- The terminal tray is properly closed, activating the micro-switch
- The battery is connected
- The battery is charging and within acceptable voltage limits

If the green Status LED is not lit with power applied to the L1 feed, disconnect power and rectify any faults.

In Service, Battery Charging and Condition Monitoring

When power is applied (initially or after an outage), the battery will be charged for 36 hours.

Thereafter, in order to maximize battery life while maintaining emergency capacity, the battery charging operates for 1 minute in every hour.

The battery is continually monitored for voltage limits and charge current acceptance (during charge pulses). If the mains power supply is interrupted, the fixture will switch to emergency mode operation at reduced light output. Expected emergency mode duration exceeds 3 hours.

If, during an emergency mode cycle, the battery capacity has deteriorated to the point that 3 hours is not achieved, then when power is restored this battery "failure" will be signaled by flashing the green status LED once every 7-8 seconds. The fault indication will be automatically reset when a successful charge/discharge cycle is completed.

Conditions for Use

The supply to the Luminaire must include a fuse which is capable of interrupting a 1.5kA short circuit current.

When used with steel wired armoured or braided cable the basket weave armour or braid is unable to carry the cable load without fracture. Therefore the cable must be clamped and cleated to prevent pulling on the cable being transmitted to the cable terminations.

Improper installation and/or operation of this luminaire may invalidate the warranty and protection methods utilised.

For maximum long term reliability and light output, the luminaire must be installed in free air.

Inspection

Within the scope of maintenance or inspection routine the following should be included:

- Protective hoses covering the connection cables.
- Cable entries must be free of corrosion.
- Perform visual mechanical and electrical inspections on a regular basis. We recommend routine checks to be made on a yearly basis. Frequency of use and environment should determine this. It is recommended to follow an Electrical Preventive Maintenance Program as described in NFPA 70B: Recommended Practice for Electrical Equipment.
- The lens should be cleaned periodically as needed to ensure continued photometric performance. Clean the lens with a damp, non-abrasive, lint free cloth. If not sufficient, use mild soap or a liquid cleaner.
- Inspect the luminaire to ensure that it is free of any obstructions or contamination (i.e. excessive dust build up). Clean with a non-abrasive, damp cloth if needed.

Repairs / Overhaul / Modification

The relevant national regulations which apply to the maintenance/servicing of electrical apparatus in explosive atmospheres shall be observed.

Any unforeseen repairs or overhaul may only be carried out with genuine Dialight spare parts.

NOTE: Should the luminaire enclosure be damaged, only a full luminaire replacement will be permitted. In case of doubt, the equipment should be returned to Dialight for inspection/repair.

WARNING:

Modifications to the device or changes of its design are not permitted.

This equipment must be operated according to the intended purpose in a perfect and undamaged condition.

Ordering Spare Parts

Replacement Batteries

Dialight Part Number ELX-BATT-KIT
(3.6V 10Ah Ni-MH battery pack)

Should any unforeseen spares be required then please contact Dialight for availability.

Disposal Recycling

When the battery is disposed of, the respective national regulations on waste disposal should be observed.

WEEE (Waste electrical & electronic equipment) registration number WEE/DC2678RY.



Technical Diagrams

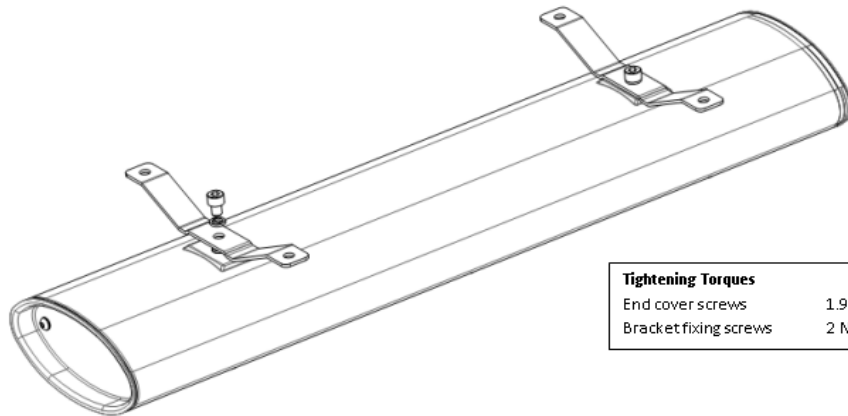
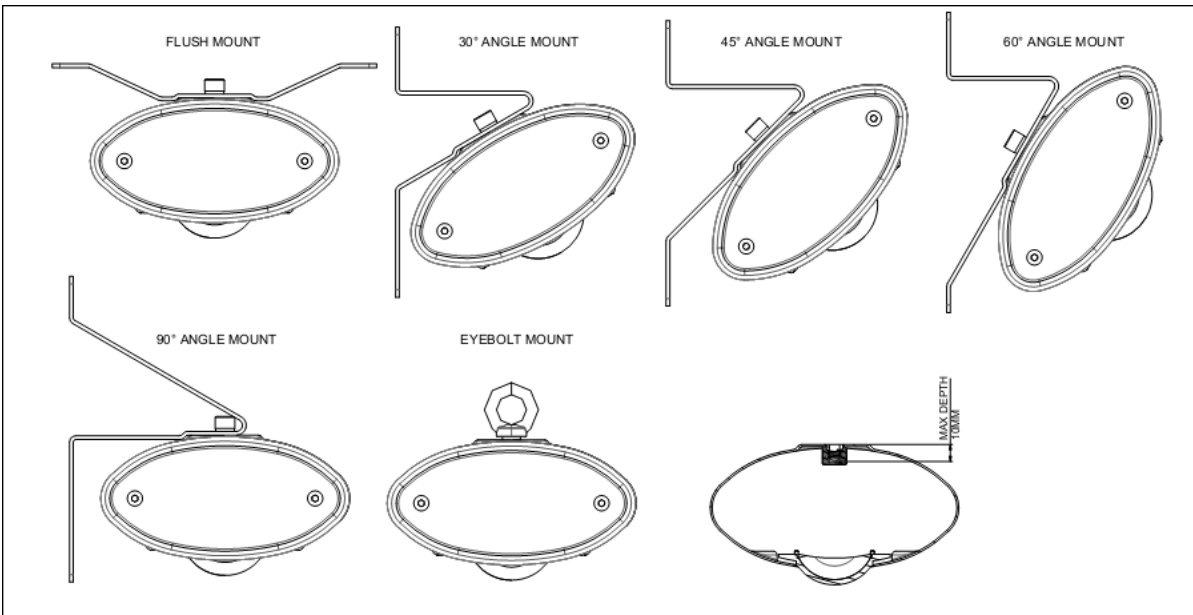
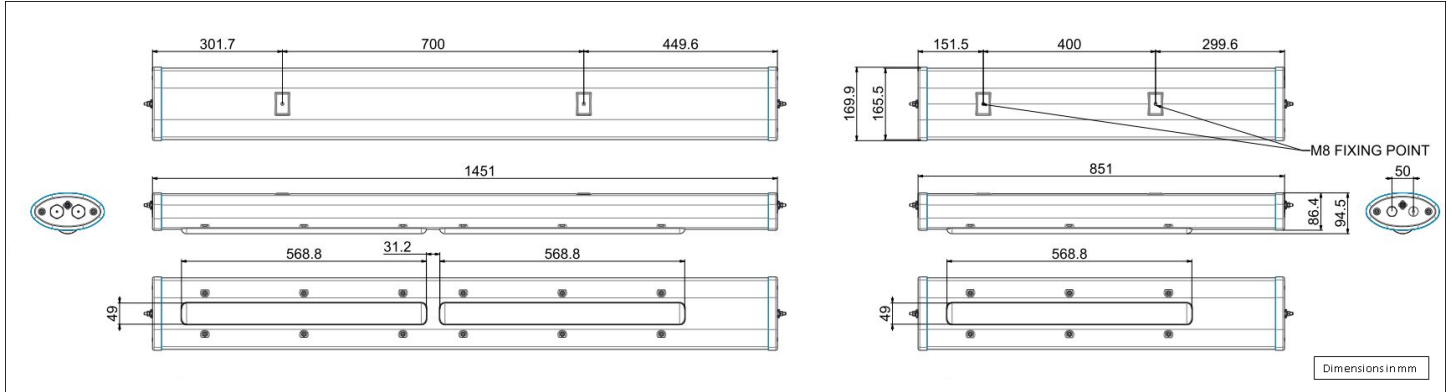

Tightening Torques	
End cover screws	1.9 Nm
Bracket fixing screws	2 Nm



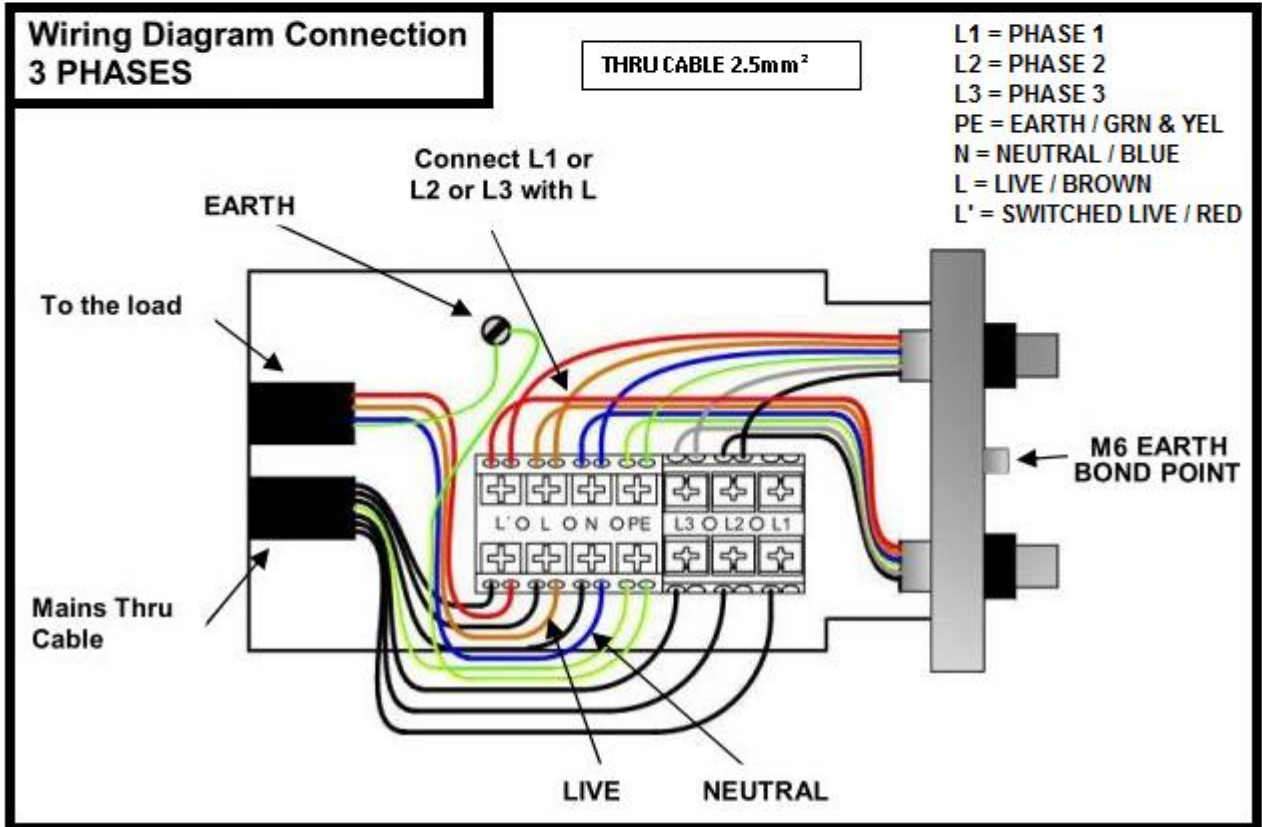
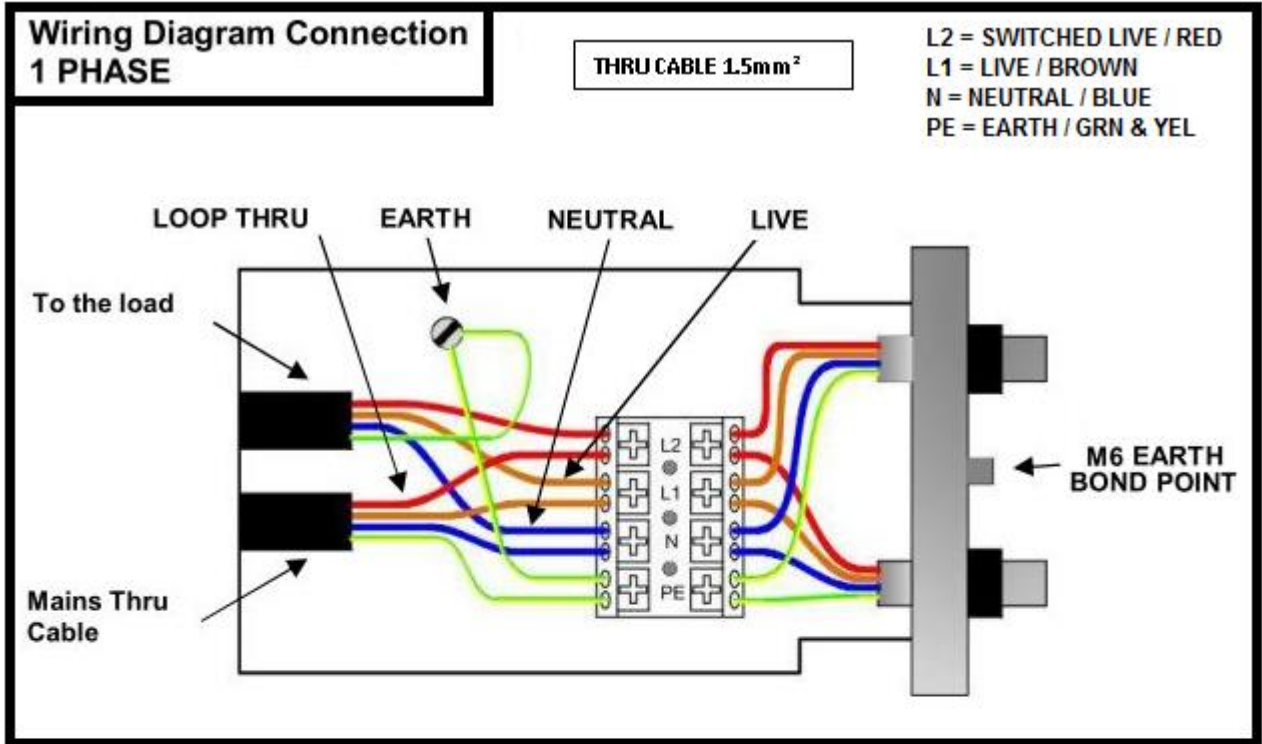



3 PHASE WIRE THROUGH

2 ft. VARIATION

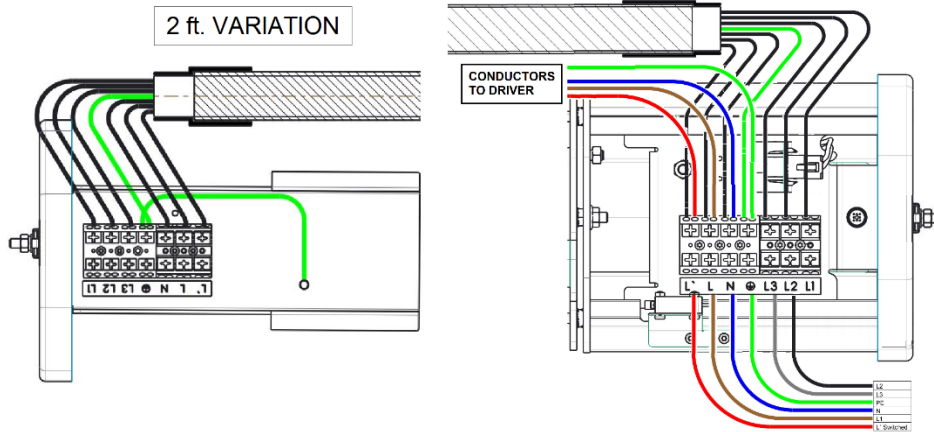

4 ft. VARIATION

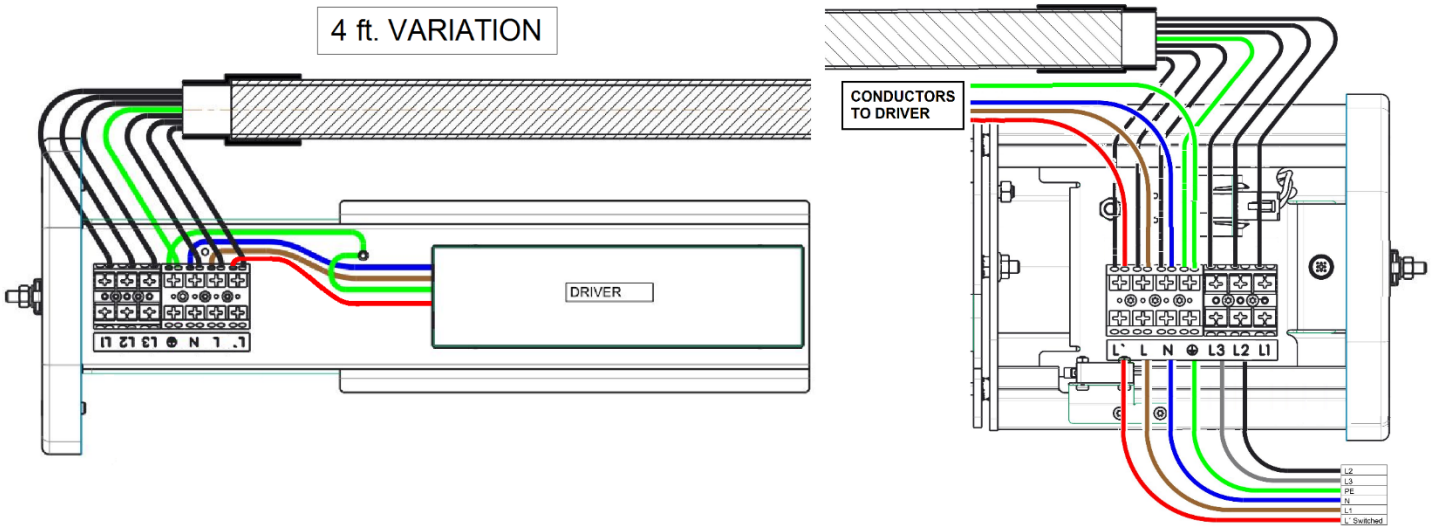

OPTIONAL SAFETY ROPE

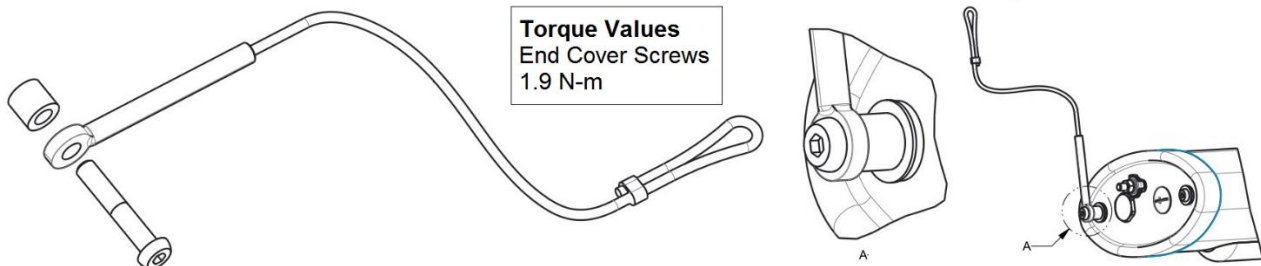

Official Statement

All statements, technical information, and recommendations contained herein are based on information and tests that Dialight believes to be reliable. The accuracy or completeness thereof is not guaranteed. In accordance with Dialight "Terms and Conditions of Sale" and since conditions of use are outside our control, the purchaser should determine the suitability of the product for his or her intended use and assumes all risk and liability whatsoever in connection therewith.





Year CE Mark Affixed:

13

EU DECLARATION OF CONFORMITY

Manufacturer: Dialight Corporation
1501 Route 34 South, Farmingdale, New Jersey, 07727, USA
+1 (732) – 919 – 3119

Equipment: Linear LED Light

Model Series: ELA Series, ELEA Series

Directives: Equipment and Protective Systems Intended for Use in Potentially Explosive Atmospheres
Directive 2014/34/EU
Low Voltage Directive 2014/35/EU
Electromagnetic Compatibility Directive 2014/30/EU

"EC Type-Examination Certificate in accordance with 94/9/EC updated to EU Type-Examination Certificate in accordance with Directive 2014/34/EU. (In accordance with Article 41 of Directive 2014/34/EU, EC Type-Examination Certificates referring to 94/9/EC that were in existence prior to the date of application of 2014/34/EU (20 April 2016) may be referenced as if they were issued in accordance with Directive 2014/34/EU. Variations to such EC Type-Examination Certificates may continue to bear the original certificate number issued prior to 20 April 2016.)"

Standards:

Luminaires - Part I: General Requirements	EN 60598-1:2008
Luminaires - Part 2 : Fixed General Purpose Luminaires	EN 60598-2-1: 1979 +A1 :1987
Radio Disturbance	EN 55015:2013
EMC - Harmonic Currents	EN 61000-3-2:2006 +A2: 2009
EMC - Immunity	EN 61547:2009
EMC - Flicker	EN 61000-3-3:2013
Explosive Atmospheres - General Requirements	EN 60079-0:2009
Explosive Atmospheres - Part 7 : Increased Safety "e"	EN 60079-7:2007
Explosive Atmospheres - Part 18 : Encapsulation "m"	EN 60079-18:2009
Explosive Atmospheres - Part 31: Dust Ignition Protection "t"	EN 60079-31:2009

Equipment Marking is based on type examination via SIRA, File SIRA12ATEX3217X and IECEx SIR 12.0093X.

 II 2 GD
 Ex e mb IIC T4 Gb
 Ex tb IIIC T135°C Db IP66/67
 Ta = -20°C to +60°C

Quality Assurance Notification: SIRA 13 ATEX M587

Quality Management System Accreditation to ISO 9001: DQS UL 10002116 QM08

We declare that our products to which this declaration relates are in conformity with the listed directives per the provisions of the aforementioned standards.

X



Date: 12-May-2017

Rizwan Ahmad, VP Engineering & Technology - Power & Connectivity
1501 Route 34 South, Farmingdale, NJ 07727 USA

Authorized contact:

Dialight Corporation
Compliance Department
1501 Route 34 South, Farmingdale, NJ 07727 USA
+1 (732) – 919 – 3119





**SCATTERGOOD
& JOHNSON LTD**
ELECTRICAL ENGINEERING & FLUID CONTROL DISTRIBUTORS

Est.1899

At Scattergood & Johnson Ltd, we pride ourselves on being a technical distributor to specialist industries.

Working with a range of quality product manufacturers across a number of specialist markets, we are not your average 'box shifter' - we are your technical and supply chain partner.

We fully support every product we sell - for free! Our internal team and external sales engineers can answer any product or application question, no matter the complexity.

Backing up this technical ability is a range of 50,000+ products available from stock for nationwide next day delivery (same day if required!), or you can collect what you need from any of our trade counters around the UK.

Select your specialist interest below to learn more about how we can help.



Online, In Branch and On the Road - Scattergood & Johnson Ltd, there when you need us.

www.scatts.co.uk