

### Technical datasheet

DIN-Rail power supply  
3 phase / 240W / 24V

### Industries & Applications



Automation



Industrial



Semi-Fab



Renewable



Comms



Test

ePLAN<sup>®</sup>  
data portal

### Features & Benefits

- ▶ **Wide 3 phase input range** for global mains voltages
- ▶ **Power boost of 120% for 2s** to support capacitive loads start-up
- ▶ **Smart Hiccup behaviour in short-circuit situation** avoids self-heating
- ▶ **Parallel mode switch** to activate load balancing behaviour
- ▶ **Two means of transient protection** increase process stability
- ▶ **Fast OVP control** protects sensitive loads
- ▶ **Very low inrush energy peak ( $I^2t$ )** saves cost for input line protection
- ▶ **Screw or push-in terminals available** to serve individual connection needs
- ▶ **High efficiency and low stand-by losses contribute to an eco-friendly energy footprint**
- ▶ **Strong CC overload behaviour** secures process reliability under demanding load conditions
- ▶ **DC-OK and inhibit relay contacts** for professional integration into applications control architecture
- ▶ Designed to meet the 7 most accepted IEC safety standards
- ▶ Exceeds regulatory EMC standards on radiated emission (Class B), surge immunity and fast transients



### Technical data abstract<sup>1</sup>

Output voltage	<i>nom.</i>	24V <sub>DC</sub>
Adjustment range	<i>max.</i>	22.5..29V <sub>DC</sub>
Output current	<i>nom.</i>	10A
Output current boost	<i>max.</i>	12A / 2s
Overload behaviour		CC + Hiccup
Hold-up time <sup>2</sup>	<i>min.</i>	22 / 44ms
Frequency range	<i>max.</i>	47 .. 63Hz
AC Input voltage	<i>nom.</i>	3x400V <sub>AC</sub>
AC Input voltage range	<i>max.</i>	3x350 .. 575V <sub>AC</sub>
Inrush current <sup>2</sup>	<i>max.</i>	42 / 42A
Inrush energy <sup>2</sup>	<i>max.</i>	0.3 / 0.8A <sup>2</sup> s
Output power	<i>nom.</i>	240W
Output power boost	<i>max.</i>	288W / 2s
Power factor <sup>2</sup>	<i>min.</i>	0.6
Conversion efficiency <sup>2</sup>	<i>max.</i>	93.1 / 93.2%
Power consumption	<i>max.</i>	18W
Stand-by consumption <sup>2</sup>	<i>max.</i>	1.6 / 2.0W
Ambient operating temperature	<i>max.</i>	-25 .. +70°C (-13 .. +158°F)
	<i>nom.</i>	-25 .. +55°C (-13 .. +131°F)
Service lifetime <sup>2</sup>	<i>min.</i>	125 000 / 136 000hrs
Service life MTBF	<i>min.</i>	5.7M hrs
Width		55mm (2 <sup>11</sup> / <sub>64</sub> in)
Height		129mm (5 <sup>5</sup> / <sub>64</sub> in)
Weight		780g (1.72lb)

<sup>1</sup> All values refer to STC unless otherwise stated

<sup>2</sup> 400 / 500V<sub>AC</sub>

### Certifications

IECEE  
CB SCHEME

IEC EN 61010-1  
IEC EN 61010-2-201  
IEC EN 62368-1 (Ed.2)

UL US  
IND.CONT.EQ

UL CSA 61010-1  
UL CSA 61010-2-201  
E356563

UL US  
E511889

UL CSA 62368-1 (Ed.2)  
E511889

### Compliance & Registration



CE

EU Low Voltage Dir. 2014/35/EU  
EU EMC Dir. 2014/30/EU  
EU RoHS Dir. 2011/65/EU

UK  
CA

Safety and EMC Reg. 2016  
Hazard. Substances Reg. 2012



EAC

Registration for Russia, Belarus,  
Armenia, Kazakhstan and  
Kyrgyzstan



China RoHS

China RoHS Law SJ/T 11363-2006







## Commercial information

<b>Order codes</b>	DRB240-24-3-A0 DRB240-24-3-A1
<b>HS code</b>	8504408290
<b>Life-cycle status</b>	launch
<b>Single packaging dimensions</b>	
Width	70mm (2 <sup>3</sup> / <sub>4</sub> in)
Height	180mm (7 <sup>3</sup> / <sub>32</sub> in)
Depth	166mm (6 <sup>17</sup> / <sub>32</sub> in)
<b>Gross weight</b>	900g (1.98lb)
<b>Multiple packaging quantity</b>	8 units
<b>Manufacturer warranty</b>	3 years

## Model selector

Model name	Output Power	Output Voltage	Feature
DRB120-12-3-A0	120W	12V <sub>DC</sub>	Screw terminals
DRB120-12-3-A1	120W	12V <sub>DC</sub>	Push-in terminals
DRB120-24-3-A0	120W	24V <sub>DC</sub>	Screw terminals
DRB120-24-3-A1	120W	24V <sub>DC</sub>	Push-in terminals
<b>DRB240-24-3-A0</b>	<b>240W</b>	<b>24V<sub>DC</sub></b>	<b>Screw terminals</b>
<b>DRB240-24-3-A1</b>	<b>240W</b>	<b>24V<sub>DC</sub></b>	<b>Push-in terminals</b>
DRB240-48-3-A0	240W	48V <sub>DC</sub>	Screw terminals
DRB240-48-3-A1	240W	48V <sub>DC</sub>	Push-in terminals

## Accessories

<b>DBM20</b>	20A buffer module for short-term hold-up or peak power in 24V <sub>DC</sub> load systems.	
<b>DRM40B</b>	40A redundancy module for creating redundant power supply systems up to 2x 20A.	
<b>DRM40</b>	40A redundancy module with additional signaling features for creating redundant power supply systems up to 2x 20A.	
<b>DDA250N</b>	250W non-isolated step-down DC/DC converter for creating additional DC bus voltages from a single DC input source.	



## Index

1.	General .....	5
2.	Electrical output .....	6
3.	Electrical input.....	7
4.	Performance .....	8
5.	Ambient conditions.....	9
6.	Reliability and service lifetime .....	10
7.	Dimensions & Mechanical data.....	11
8.	Installation clearances.....	12
9.	Wiring & Connection .....	12
10.	Signaling & Control.....	13
11.	Block diagram.....	14
12.	Device protection .....	14
13.	Electrical Safety.....	15
14.	Electromagnetic immunity .....	16
15.	Electromagnetic emission.....	16
16.	Certifications .....	17
17.	Additional safety standards .....	17
18.	Compliance & Registration .....	17
19.	Typical use-cases.....	18



## List of abbreviations

<b>avg.</b>	<i>average</i>	The arithmetic average calculated from a row of values.
<b>CC</b>		Constant output current
<b>chap.</b>		Chapter
<b>Dir.</b>		Directive
<b>eCap</b>		Electrolytic capacitor
<b>EMC</b>		Electromagnetic Compatibility
<b>Iac</b>		AC input current under a particular operating condition
<b>Iout</b>		DC output current under a particular operating condition
<b>Iout_boost</b>		Max. DC output current (time limited) without a shortfall of Uset.
<b>Iout_nom</b>		Nominal DC output current
<b>Iout_ol</b>		Max. intermittent DC output current in an overload situation and a shortfall of Uset.
<b>Iout_sc</b>		Max. short circuit DC output current and Uout close to zero.
<b>ITU</b>		International Telecommunication Union
<b>max.</b>	<i>maximum</i>	The maximum value which a parameter can assume, or which must not be exceeded. As a precondition, none of the other technical parameters exceeds its max./min. value at the same time.
<b>MCB</b>		Miniature circuit breaker
<b>min.</b>	<i>minimum</i>	The minimum value which a parameter can assume, or must not be fallen below. As a precondition, none of the other technical parameters exceeds its max./min. value at the same time.
<b>MTBF</b>		Mean Time Between Failure
<b>nom.</b>	<i>nominal</i>	The ideal or reference value of a technical parameter which is guaranteed under STC. All nominal values in this document refer to each other and represent the general specification of the device.
<b>OCP</b>		Overcurrent protection
<b>OTP</b>		Overtemperature protection
<b>OVP</b>		Overvoltage protection
<b>PELV</b>		Protective Extra Low Voltage
<b>Pout</b>		Output power under a particular operating condition
<b>Pout_boost</b>		Max. output power (time limited) without a shortfall of Uset.
<b>Pout_nom</b>		Nominal output power
<b>PSU</b>		Power supply unit
<b>Reg.</b>		Regulation
<b>SELV</b>		Safety Extra Low Voltage
<b>STC</b>		Standard test conditions (see „1. General“ on page 5)
<b>typ.</b>	<i>typical</i>	The typical value of a parameter is not guaranteed but can be assumed under STC. The min. or max. value must be determined during the engineering process of the end application.
<b>Uout</b>		DC output voltage under a particular operating condition
<b>Uout_nom</b>		Nominal DC output voltage
<b>Uset</b>		Manually set output voltage via voltage potentiometer
<b>UVP</b>		Undervoltage protection
<b>Vac</b>		AC input voltage under a particular operating condition
<b>Vac_nom</b>		Nominal AC input voltage
<b>/</b>		Separator between two values. The conditions to which the values refer can be found in the last column of the table.
<b>..</b>		Specifies a range of values.

## Table data structure

### X. Technical category

Technical parameter	Characteristic (optional)	Values	Condition (optional)
---------------------	---------------------------	--------	----------------------

## 1. General

### 1.1 Handling of the product

To ensure faultless and safe operation of the products it is required to observe the specified ambient conditions for transport and storage (see "Ambient conditions" on page 9), set-up, assembly, installation, commissioning, operation and maintenance.

### 1.2 Protection enclosure required

The device must be installed in a protective housing or control cabinet to which only qualified personnel have access.

### 1.3 Humid environments

Do not operate the device in a damp environment or in an environment where condensation is likely to occur.

### 1.4 Switch/Circuit-breaker mounting position

A switch or circuit-breaker must be mounted near the equipment.

### 1.5 Observe country-specific regulations

In addition to the product documentation, the relevant country-specific regulations for the installation of the device must be observed.

### 1.6 Prohibited electrical/mechanical modifications

The product must not be modified in any way electrically or mechanically. Modifications can result in fatal injuries and damage to property.

### 1.7 Expiry of the manufacturer's warranty

The power supply is maintenance-free. Repairs can only be carried out by the manufacturer. Opening the housing voids the manufacturer's warranty.

### 1.8 Use of third-party products

If third-party products and components are used for power or voltage increase, buffering (AC or DC side), EMC filtering, redundancies or for DC side load protection, it must be in accordance with the TDK-Lambda product specification.

### 1.9 Standard test conditions

Unless otherwise stated, all values are specified in normal mounting position, at full load, nominal input and output voltages, 25°C (131°F) ambient temperature and a run-in time of 5 minutes.

### 1.10 Normal mounting position

In the normal mounting position, the front side of the product faces into the direction of the Y axis.

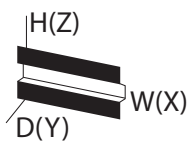
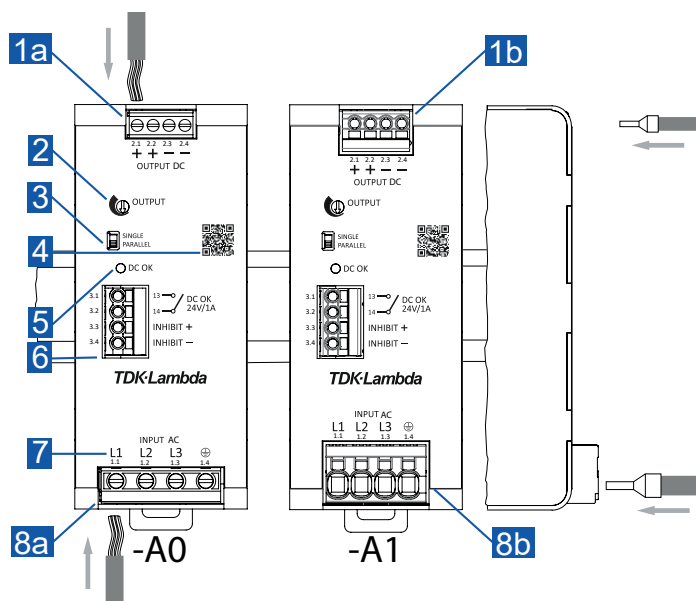

Fig. 1: Illustration of the spatial axis with reference to the DIN-Rail

### 1.11 Description of user elements



- 1a Screw terminal, DC output
- 1b Push-in terminal, DC output
- 2 Single turn potentiometer for adjusting the output voltage
- 3 Dip-switch for configuration as single or parallel operation. When changing the operating mode, the mains voltage must be disconnected.
- 4 Web link to further documentation
- 5 Green DC-OK status LED
- 6 Push-in terminal for signal contacts
- 7 Unique connection identifier usable for end-user wiring diagram
- 8a Screw terminal, AC input
- 8b Push-in terminal, AC input



For more detailed information on the input/output wiring and the connection of the signalling contacts, please refer to "Wiring & Connection" on page 12.

Fig. 2: Description of user elements

## 2. Electrical output

<b>Output voltage [U<sub>out_nom</sub>]</b>	<i>nom.</i> 24V <sub>DC</sub>	
<b>Adjustment range [U<sub>set</sub>]</b>	<i>max.</i> 22.5..29V <sub>DC</sub>	
<b>Adjustment tolerance</b>	<i>max.</i> ±3%	at upper/lower end position of voltage potentiometer
<b>Factory default</b>	24V <sub>DC</sub>	
<b>Output current [I<sub>out_nom</sub>]</b>	<i>nom.</i> 10A	
<b>Boost current [I<sub>out_boost</sub>]</b>	<i>max.</i> 12A / 2s	
<b>Overload behaviour</b>	Constant current + Hiccup	see Fig. 4
<b>Overload current</b>	<i>max.</i> 15A	400..500V <sub>AC</sub>
<b>Intermittent OL current [I<sub>out_ol</sub>]</b>	<i>max.</i> 15A / 0.3s <i>avg.</i> 1.7A / 12s	400..500V <sub>AC</sub> 400..500V <sub>AC</sub>
<b>Short-circuit proof</b>	yes	
<b>Instant SC current [I<sub>out_sc</sub>]</b>	<i>max.</i> 36A / < 1ms	400..500V <sub>AC</sub>
<b>Start-up delay</b>	<i>max.</i> 1.8s	400..500V <sub>AC</sub>
<b>Rise time</b>	<i>typ.</i> 8 / 7ms <i>typ.</i> 13 / 12ms	400 / 500V <sub>AC</sub> , 0% P <sub>out</sub> 400 / 500V <sub>AC</sub> , 100% P <sub>out</sub> , resistive load
<b>Voltage overshoot</b>	<i>typ.</i> 1.7V <sub>DC</sub>	400..500V <sub>AC</sub>
<b>Fall time</b>	<i>typ.</i> 13ms	400..500V <sub>AC</sub>
<b>Hold-up time</b>	<i>min.</i> 22 / 44ms	400 / 500V <sub>AC</sub>
<b>Capacitive load</b>	<i>max.</i> 10 000µF	
<b>Feedback voltage</b>	<i>max.</i> 35V <sub>DC</sub>	
<b>Line regulation</b>	<i>max.</i> 0.1%	350..550V <sub>AC</sub>
<b>Load regulation</b>	<i>max.</i> 0.6% <i>max.</i> 3.1%	350..550V <sub>AC</sub> 350..550V <sub>AC</sub> , parallel mode
<b>Dynamic response</b>	<i>typ.</i> ±400mVpp	350..550V <sub>AC</sub> , transient frequency 10..100Hz
<b>Ripple &amp; noise voltage</b>	<i>max.</i> 10mVpp <i>max.</i> 40mVpp	350..550V <sub>AC</sub> , +25..+70°C <sub>amb</sub> 350..550V <sub>AC</sub> , -25..+25°C <sub>amb</sub>

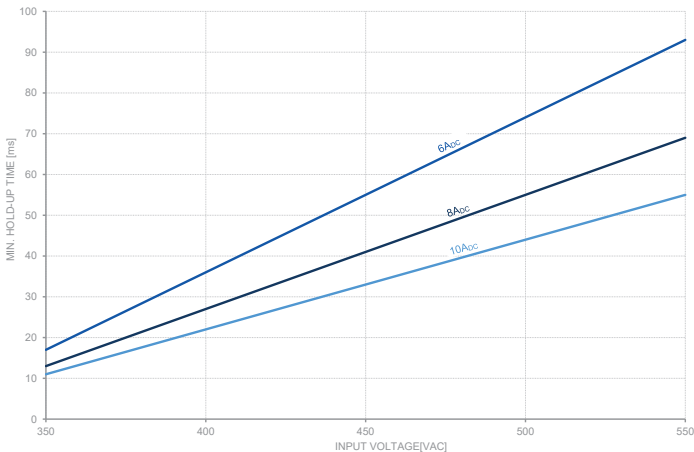

Fig. 3: Hold-up times under different load conditions and in dependence of the input voltage

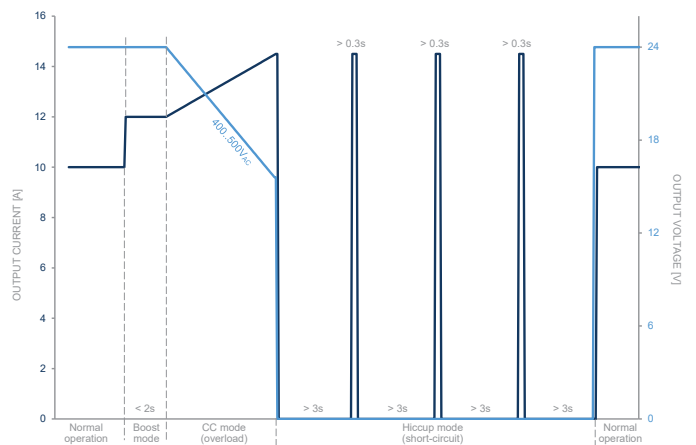

Fig. 4: Output current and voltage under different load conditions

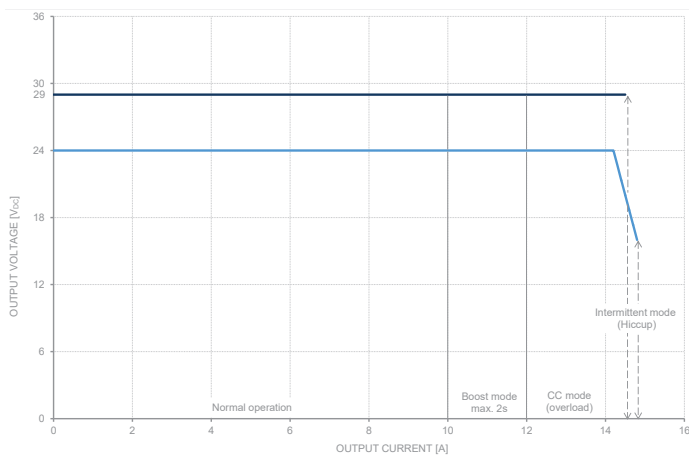

Fig. 5: Output voltage in dependence of output load current

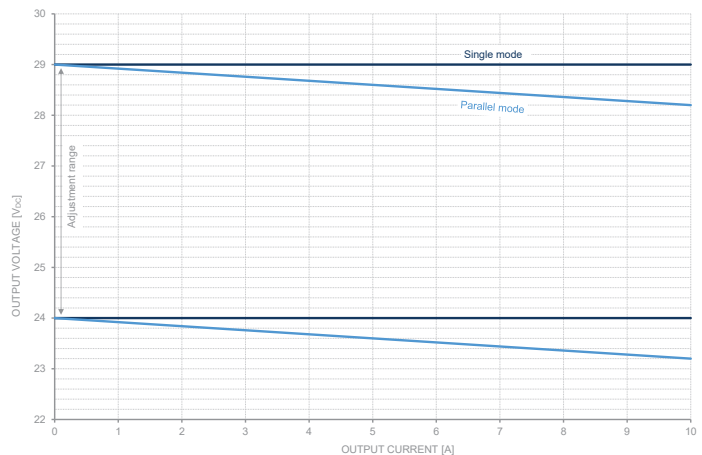
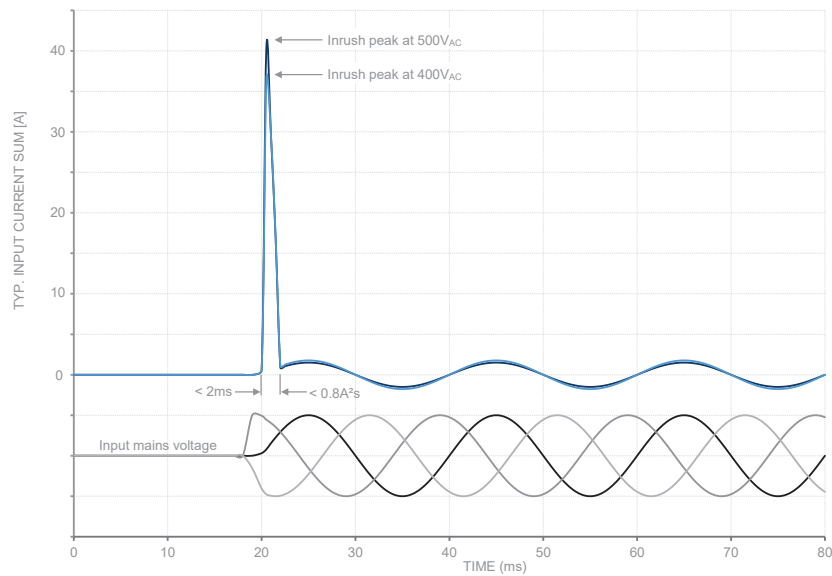

Fig. 6: Voltage drop in parallel mode depending on the load current

Unless otherwise stated, all values are specified in normal mounting position, at full load, nominal input and output voltages, 25°C (77°F) ambient temperature and a run-in time of 5 minutes.

### 3. Electrical input

<b>AC power systems</b>	TN, TT, wye	
<b>Mains Frequency</b>	<i>nom.</i>	50 / 60Hz
<b>Frequency range</b>	<i>max.</i>	47 .. 63Hz
<b>AC input voltage [V<sub>ac_nom</sub>]</b>	<i>nom.</i>	3x400V <sub>AC</sub>
<b>Voltage range</b>	<i>max.</i>	3x350 .. 575V <sub>AC</sub>
<b>Turn-ON voltage</b>	<i>typ.</i>	310V <sub>AC</sub>
<b>Turn-OFF voltage</b>	<i>typ.</i>	275V <sub>AC</sub>
<b>AC input current</b>	<i>max.</i>	3x0.8A      400 .. 500V <sub>AC</sub>
<b>AC input current RMS</b>	<i>max.</i>	3x0.59 / 3x0.50A      400 / 500V <sub>AC</sub>
<b>Crest factor</b>	<i>typ.</i>	1.38 / 1.63      400 / 500V <sub>AC</sub>
<b>Inrush current</b>	<i>max.</i>	36 / 40A      400 / 500V <sub>AC</sub> , 25°C <sub>amb</sub> , cold start
<b>Inrush energy</b>	<i>max.</i>	0.3 / 0.8A <sup>2</sup> s      400 / 500V <sub>AC</sub> , 25°C <sub>amb</sub> , cold start
<b>Input capacitance</b>	<i>max.</i>	75μF

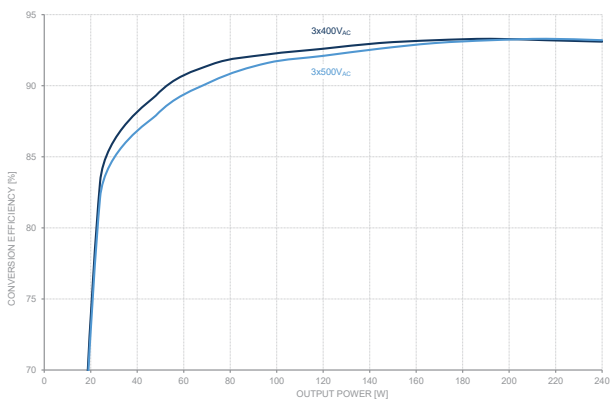

**Fig. 7:** Inrush current and energy during start-up phase

**4. Performance**

<b>Output power [P<sub>out_nom</sub>]</b>	<i>nom.</i> 240W	
<b>Boost power [P<sub>out_boost</sub>]</b>	<i>max.</i> 288W / 2s	see Fig. 10
<b>Dropped phase power</b>	<i>max.</i> 240W / continuous	2x400..500V <sub>AC</sub> , not compliant with IEC/EN 61000-3-2 harmonic currents
<b>Apparent input power</b>	<i>typ.</i> 401 / 425 VA	400 / 500V <sub>AC</sub>
<b>Active input power</b>	<i>typ.</i> 259 / 258 W	400 / 500V <sub>AC</sub>
<b>Reactive input power</b>	<i>typ.</i> 307 / 338 Var	400 / 500V <sub>AC</sub>
<b>Power factor</b>	<i>min.</i> 0.6	400..500V <sub>AC</sub>
<b>Conversion efficiency</b>	<i>min.</i> 93.1 / 93.2% <i>avg.*</i> 92.5 / 92.1%	400 / 500V <sub>AC</sub> 400 / 500V <sub>AC</sub>
<b>Power consumption</b>	<i>max.</i> 18W <i>avg.*</i> 19.5 / 20.6W	400..500V <sub>AC</sub> 400 / 500V <sub>AC</sub>
<b>Stand-by consumption</b>	<i>max.</i> 1.6 / 2.0W	400 / 500V <sub>AC</sub>

\*Weighted average: 10%@P<sub>out</sub>=20%, 50%@P<sub>out</sub>=50%, 20%@P<sub>out</sub>=80%, 20%@P<sub>out</sub>=100%



**Fig. 8:** Conversion efficiency in dependence of the output power

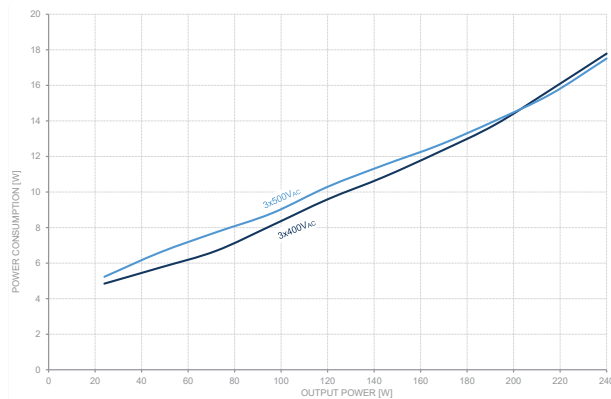

**Fig. 9:** Power losses in dependence of the output power

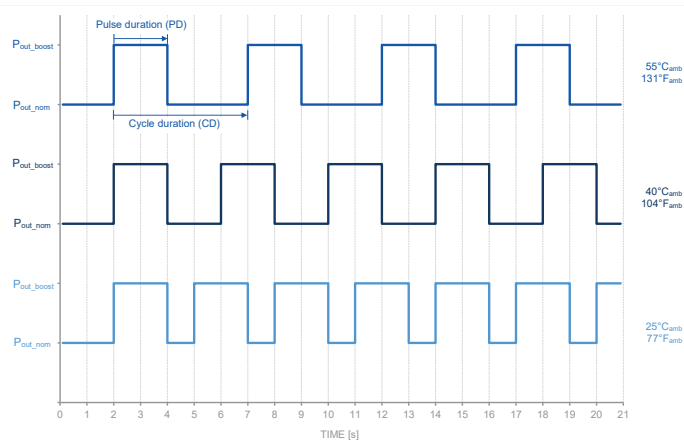

**Fig. 10:** Cycle duration in dependence of the ambient temperature and usage of the full boost power (120% / 2s)

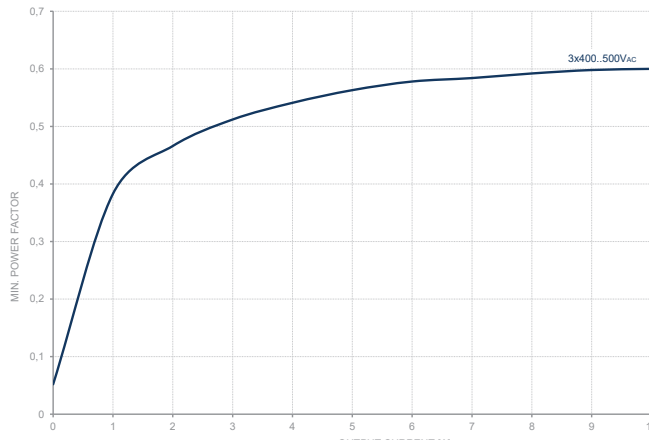

**Fig. 11:** Input power factor in dependence of the output current

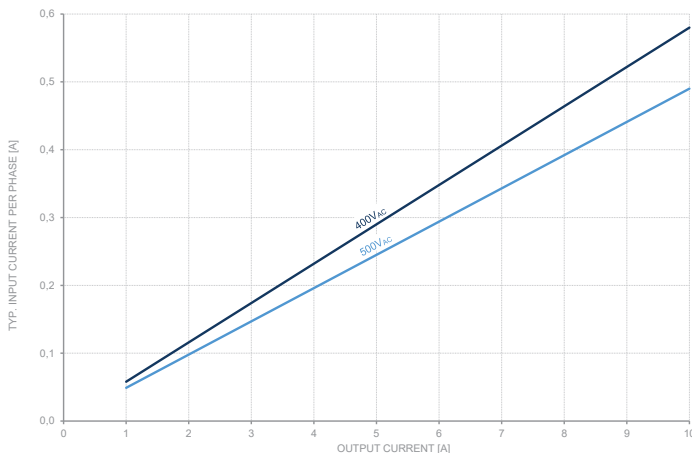

**Fig. 12:** Typical input current per phase in dependence of the load current

Unless otherwise stated, all values are specified in normal mounting position, at full load, nominal input and output voltages, 25°C (77°F) ambient temperature and a run-in time of 5 minutes.

**5. Ambient conditions**

<b>Ambient storage temperature</b>	<i>max.</i>	-40 .. +85°C <sub>amb</sub> (-40 .. +185°F <sub>amb</sub> )	
<b>Ambient operating temperature</b>	<i>nom.</i>	-25 .. +55°C <sub>amb</sub> (-13 .. +131°F <sub>amb</sub> )	normal mounting position
	<i>max.</i>	-25 .. +70°C <sub>amb</sub> (-13 .. +158°F <sub>amb</sub> )	normal mounting position
<b>Power derating</b>	<i>min.</i>	2.4W/°C <sub>amb</sub> (1.33W/°F <sub>amb</sub> )	>55°C <sub>amb</sub> (>131°F <sub>amb</sub> ), not actively controlled
<b>Cooling concept</b>		Natural convection	
<b>Relative storage humidity</b> IEC 60068-2-30	<i>max.</i>	95%	non-condensing
<b>Relative operation humidity</b> IEC 60068-2-30	<i>max.</i>	95%	non-condensing
<b>Operating altitude</b>	<i>nom.</i>	3000mASL (9842ftASL)	
	<i>max.</i>	6000mASL (19685ftASL)	not UL approved
<b>Percental power derating</b>	<i>min.</i>	7% per 1000m (7% per 3281ft)	>3000mASL (>9842ftASL)
<b>Temperature derating</b>	<i>min.</i>	5°C per 1000m (9°F per 3281ft)	>3000mASL (>9842ftASL)
<b>Atmospheric pressure</b>	<i>nom.</i>	689hPa	
	<i>max.</i>	469 .. 1070hPa	
<b>Pollution degree</b> IEC 60664-1, IEC 62477-1		2	
<b>Vibration sinusoidal</b> IEC 60068-2-6		2g / 10 .. 500Hz, 1 hour/direction X,Y,Z	non-operating, mounted on DIN-Rail
<b>Shock test sinusoidal halfwave</b> IEC 60068-2-27		30g / 11ms ±5ms, 3 bumps/direction, 9 bumps total	non-operating, mounted on DIN-Rail
<b>Audible noise</b>		Some audible noise may be heard during no load, overload or short circuit.	

**Overvoltage categories**

Underlying IEC standard	61010-1	62368-1 <sup>1)</sup>	60950-1	61558-2-16 <sup>2)</sup>	62477-1	61204-7	60664-1
Mains transient voltage	II	II	II	III	III	III	III
Creepage & Clearance	III	II	III	II	III	III	III

<sup>1)</sup> Edition 2

<sup>2)</sup> not applicable along with IEC 61204-7

**i** For altitudes above 3000mASL (9842ftASL) the next lower OVC must be considered.

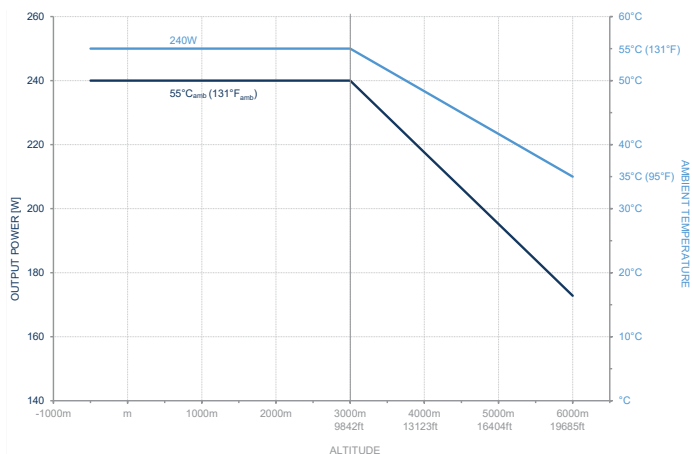

**Fig. 13:** Output power or ambient temperature derating at increasing altitudes

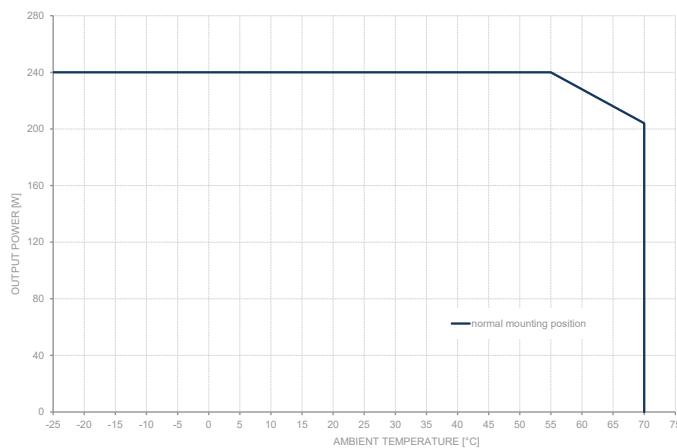

**Fig. 14:** Output power derating in dependence of the ambient temperature

Unless otherwise stated, all values are specified in normal mounting position, at full load, nominal input and output voltages, 25°C (77°F) ambient temperature and a run-in time of 5 minutes.

**6. Reliability and Service lifetime**

<b>Service lifetime</b>	<i>min.</i>	44 000 / 48 000hrs	400 / 500V <sub>AC</sub> , 100% P <sub>out</sub> , 40°C <sub>amb</sub> , 24h operating
	<i>min.</i>	82 000 / 78 000hrs	400 / 500V <sub>AC</sub> , 75% P <sub>out</sub> , 40°C <sub>amb</sub> , 24h operating
	<i>min.</i>	125 000 / 136 000hrs	400 / 500V <sub>AC</sub> , 100% P <sub>out</sub> , 25°C <sub>amb</sub> , 24h operating
<b>Early life MTBF</b> Telcordia SR-332 Issue 4	<i>min.</i>	1.1M / 1.0M / 0.8M hrs	P <sub>out_nom</sub> , 25 / 40 / 55°C <sub>amb</sub>
<b>Service life MTBF</b> Telcordia SR-332 Issue 4	<i>min.</i>	5.7M / 4.0M / 2.3M hrs	P <sub>out_nom</sub> , 25 / 40 / 55°C <sub>amb</sub>

**i** The maximum service lifetime guaranteed by the eCap manufacturer is 131 400hrs (15 years). All values above are theoretically calculated.

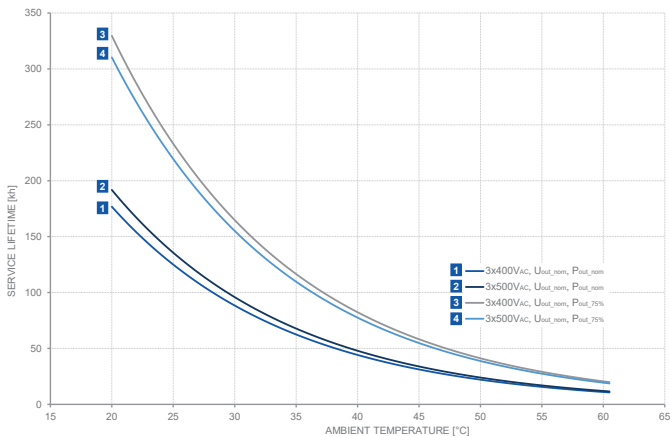

**Fig. 15:** Power supply service lifetime in dependence of ambient temperature

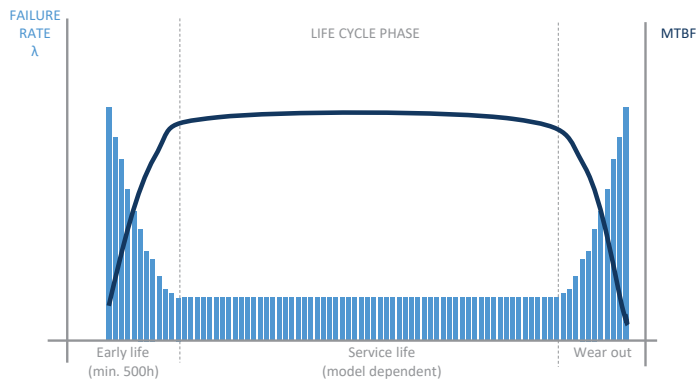
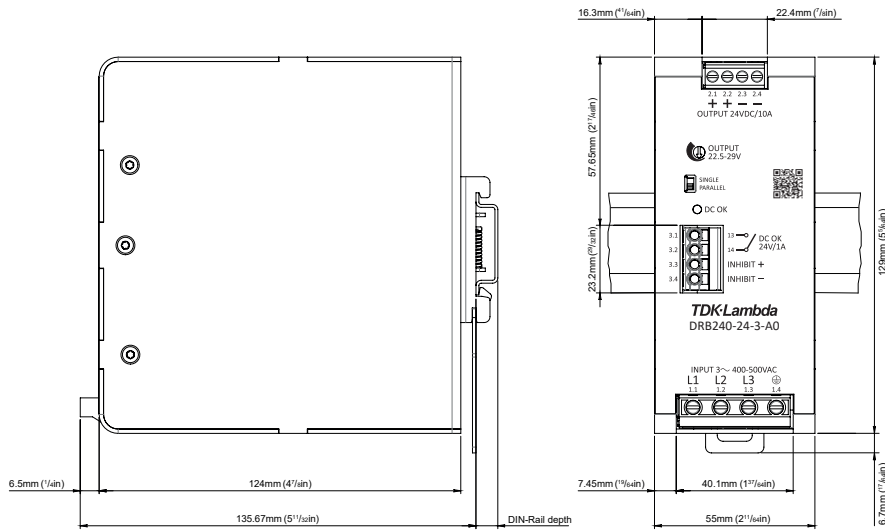

**Fig. 16:** Generic diagram visualising failure rate and MTBF values during the products life-cycle

Unless otherwise stated, all values are specified in normal mounting position, at full load, nominal input and output voltages, 25°C (77°F) ambient temperature and a run-in time of 5 minutes.

**7. Dimensions & Mechanical data**

<b>Enclosure material</b>	Aluminum	
<b>Cover material</b>	Aluminum	
<b>Inflammability class</b>	V0	Enclosure, cover and terminals
UL 94		
<b>Width</b>	55.0mm (2 <sup>11</sup> / <sub>64</sub> in)	
<b>Height</b>	129.0mm (5 <sup>5</sup> / <sub>64</sub> in)	
<b>Depth</b>	w/o DIN-Rail	
Screw terminal model (-A0)	135.7mm (5 <sup>11</sup> / <sub>32</sub> in)	
Push-in terminal model (-A1)	138.2mm (5 <sup>7</sup> / <sub>16</sub> in)	
<b>Weight</b>	780g (1.72lb)	
<b>Lever arm</b>	max. 62mm (2 <sup>7</sup> / <sub>16</sub> in)	into the direction of Y axis
<b>Torsional moment on DIN-Rail</b>	max. 0.47Nm (4.16lb in)	into the direction of Z axis
<b>Enclosure openings</b>	max. 7mm (9/ <sub>32</sub> in)	
<b>DIN-Rail types</b>	TH 35-7.5, TH 35-15	
IEC 60715		



**Fig. 17: Dimension drawing of DRB240-24-3-A0**

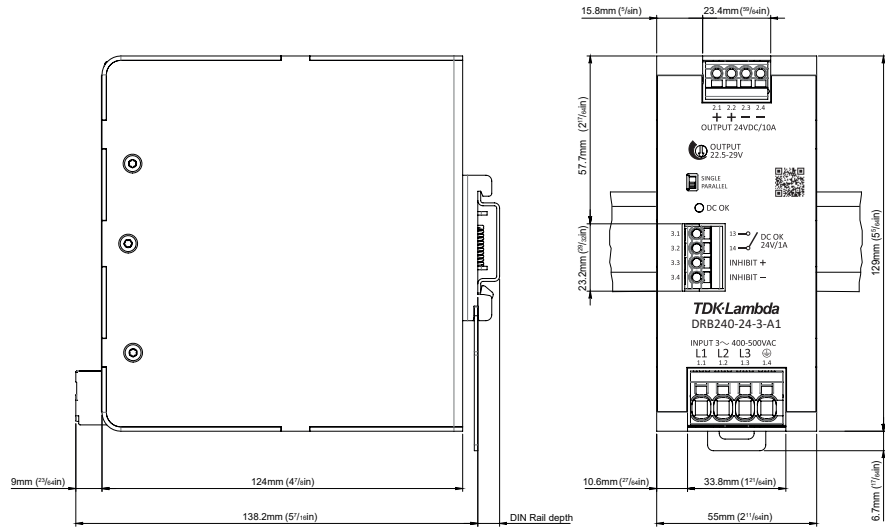

**Fig. 18: Dimension drawing of DRB240-24-3-A1**

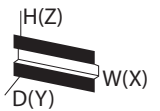

Unless otherwise stated, all values are specified in normal mounting position, at full load, nominal input and output voltages, 25°C (77°F) ambient temperature and a run-in time of 5 minutes.

## 8. Installation clearances

### Vertically (Z axis)

Top side	<b>1</b>	<i>min.</i> 40mm ( <sup>137</sup> / <sub>64</sub> in)	installation above heat sources not permitted
Bottom side	<b>2</b>	<i>min.</i> 30mm ( <sup>13</sup> / <sub>16</sub> in)	

### Horizontally (X axis)

Left side	<b>3</b>	<i>min.</i> 15mm ( <sup>19</sup> / <sub>32</sub> in)	to active components (heat sources) to active components (heat sources)
Right side	<b>4</b>	<i>min.</i> 15mm ( <sup>19</sup> / <sub>32</sub> in)	
Left side	<b>3</b>	<i>min.</i> 5mm ( <sup>13</sup> / <sub>64</sub> in)	
Right side	<b>4</b>	<i>min.</i> 5mm ( <sup>13</sup> / <sub>64</sub> in)	

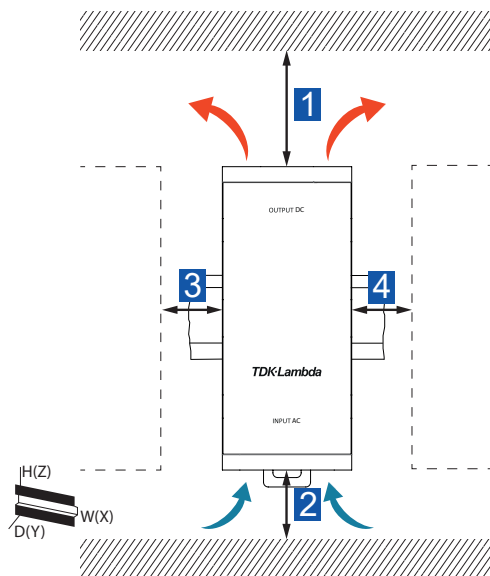

Fig. 19: Installation clearances in normal mounting position

## 9. Wiring & Connection

	Input	Output	Signaling
<b>DRB240-24-3-A0</b>			
Terminal type	Slotted screw	Slotted screw	Push-in
Recommended screw driver	SL 0.8x4.0mm (SL <sup>1</sup> / <sub>32</sub> x <sup>1</sup> / <sub>8</sub> in)	SL 0.6x3.5mm (SL <sup>1</sup> / <sub>32</sub> x <sup>9</sup> / <sub>64</sub> in)	SL 0.5x3.0mm (SL <sup>1</sup> / <sub>64</sub> x <sup>1</sup> / <sub>8</sub> in)
Solid wire	0.5-4.0mm <sup>2</sup> (16-10AWG)	0.5-2.5mm <sup>2</sup> (24-12AWG)	0.2-2.5mm <sup>2</sup> (26-12AWG)
Flexible wire	0.5-4.0mm <sup>2</sup> (16-10AWG)	0.5-2.5mm <sup>2</sup> (24-12AWG)	0.2-2.5mm <sup>2</sup> (26-12AWG)
Standard ferrules	0.25-2.5mm <sup>2</sup>	0.25-1.5mm <sup>2</sup>	0.2-1.5mm <sup>2</sup>
Uninsulated ferrules	0.25-2.5mm <sup>2</sup>	0.25-1.5mm <sup>2</sup>	0.2-2.5mm <sup>2</sup>
Stripping length	6-7mm ( <sup>15</sup> / <sub>64</sub> - <sup>9</sup> / <sub>32</sub> in)	7-8mm ( <sup>9</sup> / <sub>32</sub> - <sup>5</sup> / <sub>16</sub> in)	9-10mm ( <sup>23</sup> / <sub>64</sub> - <sup>25</sup> / <sub>64</sub> in)
Tightening torque	0.5-0.8Nm (4.4-7.0lb in)	0.5Nm (4.4lb in)	-
<b>DRB240-24-3-A1</b>			
Terminal type	Push-in	Push-in	Push-in
Recommended screw driver	SL 0.6x3.5mm (SL <sup>1</sup> / <sub>32</sub> x <sup>9</sup> / <sub>64</sub> in)	SL 0.5x3.0mm (SL <sup>1</sup> / <sub>64</sub> x <sup>1</sup> / <sub>8</sub> in)	SL 0.5x3.0mm (SL <sup>1</sup> / <sub>64</sub> x <sup>1</sup> / <sub>8</sub> in)
Solid wire	0.2-10.0mm <sup>2</sup> (24-8AWG)	0.2-2.5mm <sup>2</sup> (26-12AWG)	0.2-2.5mm <sup>2</sup> (26-12AWG)
Flexible wire	0.2-6.0mm <sup>2</sup> (24-8AWG)	0.2-2.5mm <sup>2</sup> (26-12AWG)	0.2-2.5mm <sup>2</sup> (26-12AWG)
Standard ferrules	0.25-4.0mm <sup>2</sup>	0.2-1.5mm <sup>2</sup>	0.2-1.5mm <sup>2</sup>
Uninsulated ferrules	0.25-6.0mm <sup>2</sup>	0.2-2.5mm <sup>2</sup>	0.2-2.5mm <sup>2</sup>
Stripping length	15mm ( <sup>19</sup> / <sub>32</sub> in)	9-10mm ( <sup>23</sup> / <sub>64</sub> - <sup>25</sup> / <sub>64</sub> in)	9-10mm ( <sup>23</sup> / <sub>64</sub> - <sup>25</sup> / <sub>64</sub> in)

**i** In compliance to IEC/EN/UL 62368-1 (Ed.2) ferrules are required if flexible wires are used. In compliance with IEC/EN/UL 61010-1, 61010-2-201 appropriate copper wires must be used that withstand operating temperatures of at least 75°C (167°F) in ambients NOT exceeding 40°C (104°F), and 90°C (194°F) in ambients exceeding 40°C (104°F).

## 10. Signaling & Control

### DC OK

Type		Relay contact	
Characteristic		N/O	
Closing		$U_{out} > 95\% U_{set}$	duration min. 100ms
Opening		$U_{out} < 90\% U_{set}$	duration min. 100ms
Resistive load	<i>max.</i>	1A	24V <sub>DC</sub>
Trigger hysteresis	<i>typ.</i>	1.2V	

### Remote ON/OFF

Type		Electrical contact	
Characteristic		Inhibit	
ON threshold	<i>typ.</i>	6V	
OFF threshold	<i>typ.</i>	4V	
Restart delay	<i>max.</i>	5s	
Open circuit voltage	<i>max.</i>	30V	OFF mode
Current	<i>max.</i>	10mA	ON mode
Reference potential		DC-	
Parallel connection		yes	
Active discharging		no	OFF mode

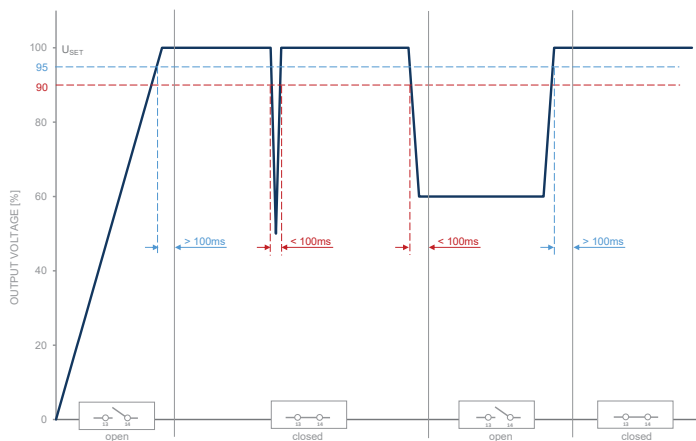

**Fig. 20:** DC-OK relay characteristic in dependence of output voltage changes

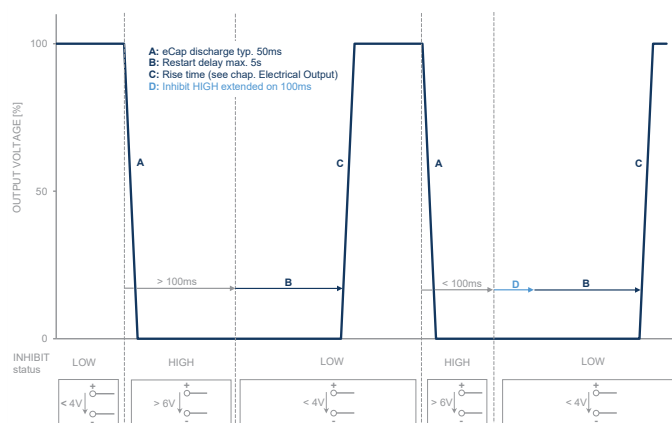

**Fig. 21:** Control of the output voltage in dependence of the inhibit relay status.

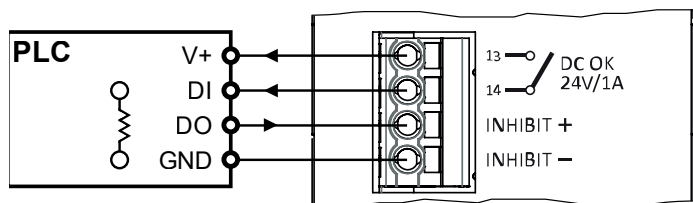

**Fig. 22:** Generic connection diagram of DC OK and INHIBIT contacts

Unless otherwise stated, all values are specified in normal mounting position, at full load, nominal input and output voltages, 25°C (77°F) ambient temperature and a run-in time of 5 minutes.

## 11. Block diagram

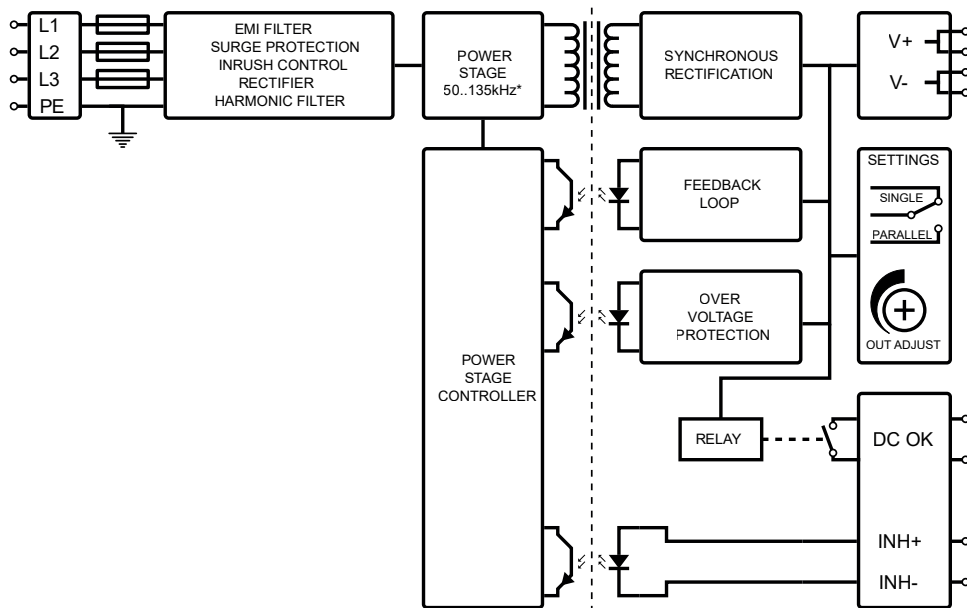

Fig. 23: Functional block diagram

\*dependent on  $U_{out}$  and  $I_{out}$

## 12. Device protection

<b>Ingress protection degree</b> IEC 60529	IP 20	
<b>NEMA classification</b> NEMA 250-2018	NEMA 1	
<b>Overvoltage protection</b>	<i>max.</i> 32V <sub>DC</sub> auto-recovery	
<b>Undervoltage protection (UVP)</b>	<i>max.</i> 270V <sub>AC</sub>	
<b>Overtemperature protection (OTP)</b>	<i>max.</i> 80°C <sub>amb</sub> (176°F <sub>amb</sub> ) auto-recovery	85% P <sub>out</sub>
<b>Overcurrent protection (OCP)</b>	<i>max.</i> 150% auto-recovery	
<b>Integrated input fuse</b>	3x T3.15A at L pins	not DC capable, not user replaceable
<b>Suitable MCB types</b> IEC 60898-1	B or C characteristic, 6/8/10A	
<b>Transient protection</b>		
1st level	MOV (Metal Oxide Varistor)	
2nd level	GDT (Gas Discharge Tube)	

**13. Electrical Safety**

<b>Class of protection</b> IEC 61140	I	PE connection required
<b>Safety Extra Low Voltage</b> IEC 61010-1	SELV	
<b>Protective Extra Low Voltage</b> IEC 60204-1	PELV	Output must be earthed in the end application
<b>Protective ground resistance</b>	<i>max.</i> 100mΩ	
<b>Ground leakage current</b> IEC 60990	<i>max.</i> 0.9mA <i>max.</i> 1.0mA	TN/TT mains, 3x575V <sub>AC</sub> , 50Hz TN/TT mains, 3x575V <sub>AC</sub> , 60Hz
<b>Touch current</b> IEC 60990	<i>max.</i> 40μA <i>max.</i> 50μA	TN/TT mains, 3x575V <sub>AC</sub> , 50Hz TN/TT mains, 3x575V <sub>AC</sub> , 60Hz

Insulation strength	Type test (60s) IEC 61010-1	Routine test (3s) IEC 61010-1	Field test (3s)
Input / Output	3510V <sub>AC</sub>	3510V <sub>AC</sub>	3510V <sub>AC</sub>
Input / PE	2210V <sub>AC</sub>	2210V <sub>AC</sub>	2210V <sub>AC</sub>
Input / DC OK	3510V <sub>AC</sub>		3510V <sub>AC</sub>
Input / INHIBIT	3510V <sub>AC</sub>		3510V <sub>AC</sub>
Output / PE	1390V <sub>AC</sub>	1390V <sub>AC</sub>	1390V <sub>AC</sub>
Output / DC OK	1390V <sub>AC</sub>		1390V <sub>AC</sub>
Output / INHIBIT	1390V <sub>AC</sub>		1390V <sub>AC</sub>
DC OK / INHIBIT	1390V <sub>AC</sub>		1390V <sub>AC</sub>

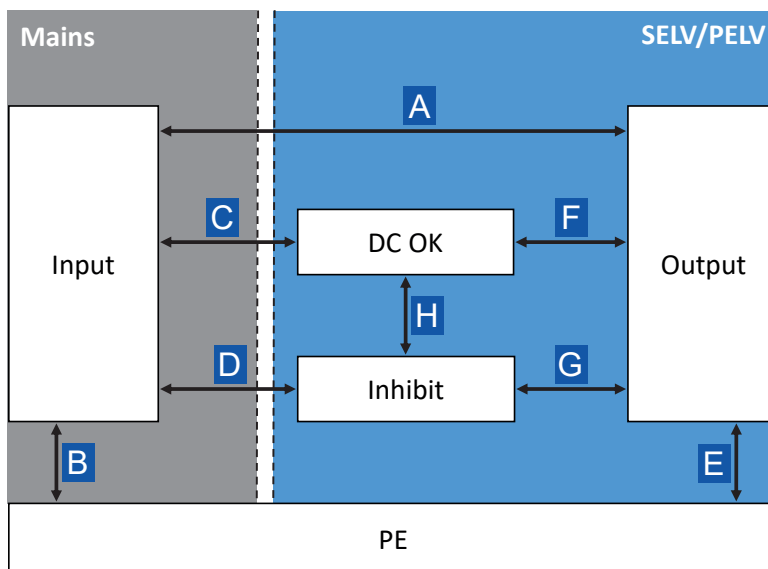

Fig. 24: Schematic of the insulation paths

Unless otherwise stated, all values are specified in normal mounting position, at full load, nominal input and output voltages, 25°C (77°F) ambient temperature and a run-in time of 5 minutes.

## 14. Electromagnetic immunity

Investigated under generic standards IEC/EN 61000-6-2 (2019) - Immunity for industrial environments.

<b>Electrostatic contact discharge</b> IEC/EN 61000-4-2	4kV	Criterion A	330Ω / 150pF
<b>Electrostatic air discharge</b> IEC/EN 61000-4-2	8kV	Criterion A	330Ω / 150pF
<b>Electromagnetic RF field<sup>1)</sup></b> IEC/EN 61000-4-3	10V/m	Criterion A	80MHz.. 1GHz
	3V/m	Criterion A	1.4GHz.. 2GHz
	1V/m	Criterion A	2GHz.. 2.7GHz
<b>Fast transients (burst)</b> IEC/EN 61000-4-4			
Input <sup>2)</sup>	4kV	Criterion A	5kHz
Output	2kV	Criterion A	5kHz
Signal contact <sup>2)</sup>	2kV	Criterion A	5kHz
<b>Surge voltages</b> IEC/EN 61000-4-5			
Input symmetrical (L-L) <sup>2)</sup>	2kV	Criterion A	2Ω+18μF, for Φ = 0°, 90°, 180°, 270°
Input asymmetrical (L-PE) <sup>2)</sup>	4kV	Criterion A	12Ω+9μF, for Φ = 0°, 90°, 180°, 270°
Output symmetrical (L-L)	0.5kV	Criterion A	2Ω+18μF
Output asymmetrical (L-PE)	1kV	Criterion A	12Ω+9μF
<b>Conducted disturbances Input, signal line, PE<sup>3)</sup></b> IEC/EN 61000-4-6	10V	Criterion A	150kHz.. 80MHz
<b>Power frequency magnetic field</b> IEC/EN 61000-4-8	30A/m	Criterion A	50Hz, 60s each axis (x, y, z)
<b>Voltage dips/sags and interruptions</b> IEC/EN 61000-4-11, 61000-4-34	500ms	Criterion A	400VAC at 70%, 50Hz
	200ms	Criterion A	400VAC at 40%, 50Hz
	20ms	Criterion A	400VAC at 0%, 50Hz
	5000ms	Criterion C	400VAC at 0%, 50Hz

<sup>1</sup> Except for the ITU broadcast frequency bands 87 .. 107MHz, 174 .. 230MHz and 470 .. 790MHz, where the level shall be 3V/m.

<sup>2</sup> Exceeds the requirements of the European Low Voltage Directive 2014/35/EU

<sup>3</sup> Except for the ITU broadcast frequency bands 47 .. 68MHz, where the level shall be 3V.

### Performance level definitions:

#### Criterion A:

The device continues operation as intended during and after the test. The specified performance level accepts a change of ±10% on nominal output voltage and current. There is neither a violation of the performance level, nor a loss of function if the device is used as intended.

#### Criterion B:

The device continues operation as intended after the test. The specified performance level accepts a change of ±10% on nominal output voltage and current. There is neither a violation of the performance level, nor a loss of function if the device is used as intended. During the test a violation of the performance level is allowed.

#### Criterion C:

A temporary loss of function is allowed, provided the function is auto-recoverable, or can be restored by the operation of the controls.



## 15. Electromagnetic emission

Investigated under generic standards IEC/EN 61000-6-3 (2007) + A1 (2011) / AC (2012) - Emission standard for residential, commercial and light-industrial environments.

<b>Conducted noise emission Input</b> EN 55011, CISPR 11	Class B	150kHz.. 30MHz
<b>Radiated noise emission Input</b> EN 55011, CISPR 11	Class B	30MHz.. 1GHz
<b>Harmonic currents Input</b> IEC/EN 61000-3-2	Class A	0kHz.. 2kHz
<b>Voltage changes, voltage fluctuations and flicker Input</b> IEC/EN 61000-3-3	PASS	50Hz

Unless otherwise stated, all values are specified in normal mounting position, at full load, nominal input and output voltages, 25°C (77°F) ambient temperature and a run-in time of 5 minutes.

## 16. Certifications







	UL 61010-1 CAN/CSA-C22.2 No. 61010-1	Safety requirements for electrical equipment for measurement, control, and laboratory use - Part 1: General requirements
	UL 61010-2-201 CAN/CSA-C22.2 No. 61010-2-201	Safety requirements for electrical equipment for measurement, control, and laboratory use - Part 2-201: Particular requirements for control equipment UL-File: E356563
	IEC EN 61010-1	Safety requirements for electrical equipment for measurement, control, and laboratory use - Part 1: General requirements
	IEC EN 61010-2-201	Safety requirements for electrical equipment for measurement, control, and laboratory use - Part 2-201: Particular requirements for control equipment
	IEC EN 62368-1 (Ed.2)	Audio/video, information and communication technology equipment - Part 1: Safety requirements
	UL 62368-1 (Ed. 2)	Audio/video, information and communication technology equipment - Part 1: Safety requirements UL-File: E511889

## 17. Additional safety standards

The safety design of the product complies additionally with the following harmonised standards.

IEC 60950-1	Information technology equipment - Safety - Part 1: General requirements
IEC/EN 62477-1	Safety requirements for power electronic converter systems and equipment - Part 1: General
IEC/EN 61204-7	Low-voltage switch mode power supplies - Part 7: Safety requirements
IEC/EN 61558-2-16	Safety of transformers, reactors, power supply units and similar products for supply voltages up to 1100 V - Part 2-16: Particular requirements and tests for switch mode power supply units and transformers for switch mode power supply units
EN 60204-1	Safety of machinery - Electrical equipment of machines - Part 1: General requirements

## 18. Compliance & Registration

	Conformity with health, safety, and environmental protection standards for products sold within the European Economic Area (EEA).
	UKCA (UK Conformity Assessed) is the product marking that is used for certain goods being placed on the United Kingdom market.
	Registration mark to indicate products conformity to the technical regulations of the Eurasian Customs Union (Russia, Belarus, Armenia, Kazakhstan and Kyrgyzstan).
	The Waste Electrical and Electronic Equipment Directive (WEEE Directive) is the European Community Directive 2012/19/EU on collection, recycling and recovery targets for all types of electrical goods.
	The Restriction of Hazardous Substances Directive 2011/65/EU (RoHS 2) regulates the use of certain hazardous substances in electrical and electronic equipment.
	Registration, Evaluation, Authorisation and Restriction of Chemicals (REACH) is a European Union regulation that addresses the production and use of chemical substances, and their potential impacts on both human health and the environment.

Unless otherwise stated, all values are specified in normal mounting position, at full load, nominal input and output voltages, 25°C (77°F) ambient temperature and a run-in time of 5 minutes.

## 19. Typical use-cases

### 19.1 Parallel Operation

For the purpose of power increase, power supplies can be paralleled. Furthermore, a paralleling can be done for limited redundancy purposes in order to backup malfunctions occurring on the primary (AC) side of the power supplies. The following measures must be taken into account:

- ▶ Only power supplies of the same series and power rating must be paralleled
- ▶ The dip switch on the front side of the power supplies must be switched to PARALLEL
- ▶ Load wiring shall be identical in terms of length and cross section
- ▶ The output voltage of the power supplies shall be adjusted to the same value ( $\pm 100\text{mV}$ )
- ▶ All paralleled power supplies must be operated under the same ambient conditions
- ▶ The power supplies must not be operated under any condition which requires a power derating (e.g. altitudes above 3000mASL (9842ftASL), temperatures above  $55^\circ\text{C}_{\text{amb}}$  ( $131^\circ\text{F}_{\text{amb}}$ ), etc.)
- ▶ If more than three power supplies are paralleled, each output must be protected by a decoupling module (e.g. DRM series), MCB, diode, or fuse
- ▶ The increased installation clearances must be considered (see "Installation clearances" on page 12)

**i** In parallel operations the values of output load regulation, inrush currents, EMI, harmonic and leakage currents will increase.

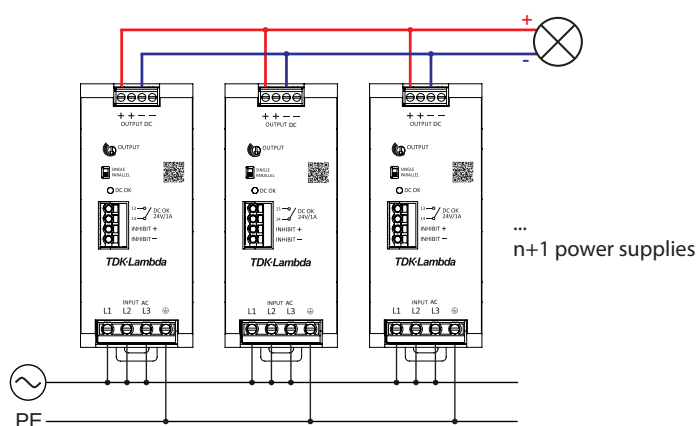

Fig. 25: Connection scheme for paralleling n+1 power supplies

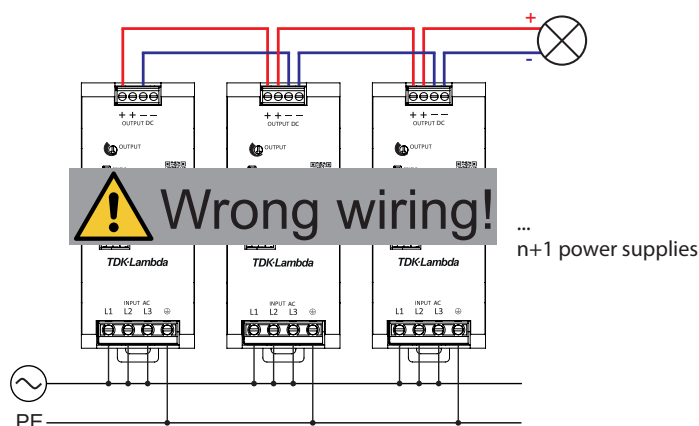

Fig. 26: Example scheme of wrong parallel wiring

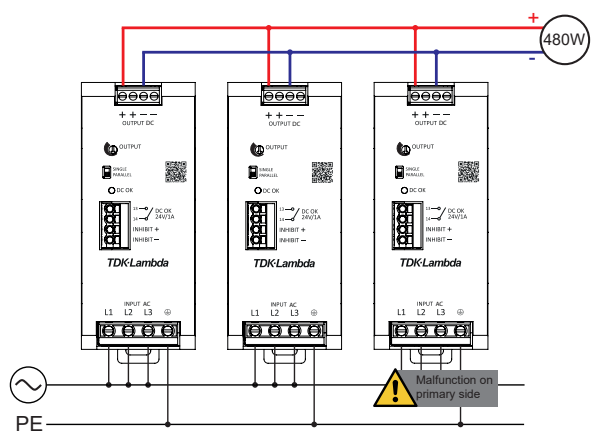

Fig. 27: Example of a 480W application with limited redundancy

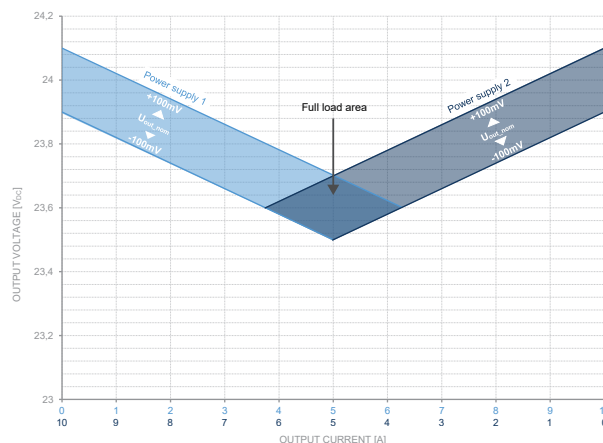

Fig. 28: Schematic of load sharing in PARALLEL mode if PSUs are adjusted to  $U_{\text{out,nom}} \pm 100\text{mV}$

Unless otherwise stated, all values are specified in normal mounting position, at full load, nominal input and output voltages,  $25^\circ\text{C}$  ( $77^\circ\text{F}$ ) ambient temperature and a run-in time of 5 minutes.

### 19.2 Series operation

For the purpose of higher load voltages, power supplies can be connected in series. The following measures must be taken into account:

- ▶ The output voltage sum must not exceed 250V<sub>DC</sub>
- ▶ If the output voltage sum exceeds 60V<sub>DC</sub>, a safeguard against unintended touching must be considered
- ▶ Only power supplies of the same series and power rating must be connected in series
- ▶ The dip switch on the front side of the power supplies must be switched to SINGLE
- ▶ All power supplies in series must be operated under the same ambient conditions
- ▶ The power supplies must not be operated under any condition which requires a power derating (e.g. altitudes above 3000mASL (9842ftASL), temperatures above 55°C<sub>amb</sub> (131°F<sub>amb</sub>), etc.)
- ▶ The increased installation clearances must be considered (see "Installation clearances" on page 12)

**i** In series operations the values of output load regulation, inrush currents, EMI, harmonic and leakage currents will increase.

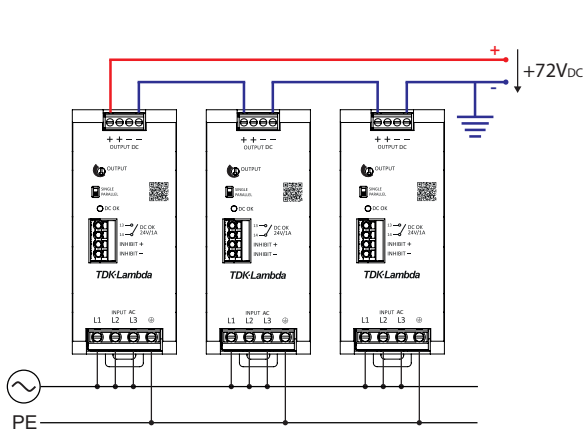

Fig. 29: Connection scheme for series operation with positive voltage level

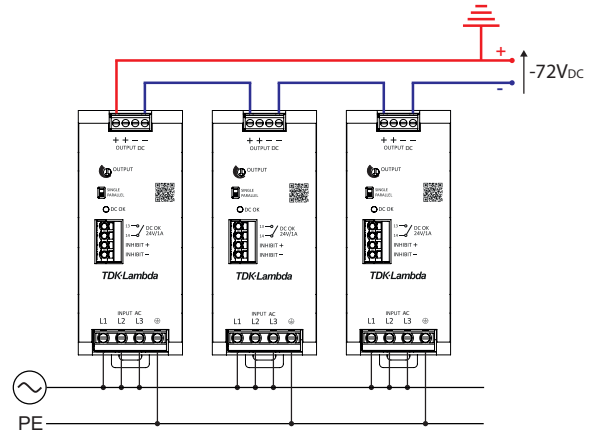

Fig. 30: Connection scheme for series operation with negative voltage level

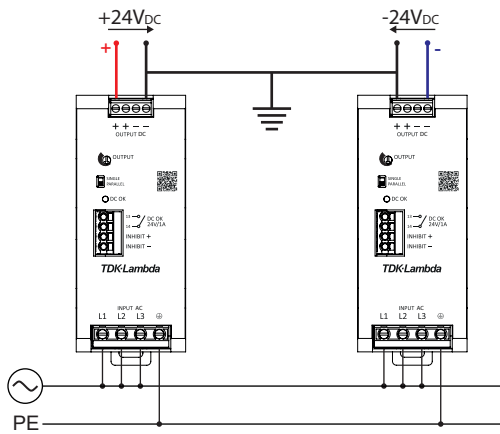

Fig. 31: Connection scheme for series operation with centre tap

Unless otherwise stated, all values are specified in normal mounting position, at full load, nominal input and output voltages, 25°C (77°F) ambient temperature and a run-in time of 5 minutes.

### 19.3 Two-phase operation

The device is capable to run continuously on two phases of a 3-phase power grid. A power derating is not required if all parameters stay within the technical product specification. In particular, all conditions associated with a power derating must be carefully considered.

Please note if running on two phases:

- ▶ Power losses will increase and can no longer be guaranteed as specified for 3-phase operation
- ▶ Hold-up times as specified for 3-phase operation can no longer be guaranteed
- ▶ The device will go into OTP mode if operating permanently at input voltages below 350V<sub>AC</sub>
- ▶ The device is no more compliant with IEC/EN 61000-3-2 harmonic current limits
- ▶ Safety approvals under UL 61010-1, -2-201 and UL 62368-1 (Ed.2) are no more applicable

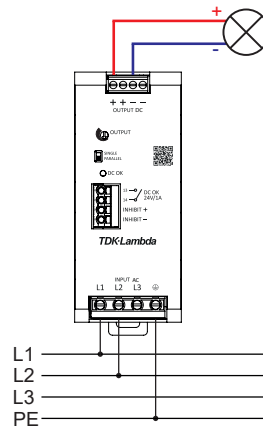

Fig. 32: Connection diagram for 2-phase operation

## Figures register

Fig. 1: Illustration of the spatial axis with reference to the DIN-Rail .....	5
Fig. 2: Description of user elements.....	5
Fig. 3: Hold-up times under different load conditions and in dependence of the input voltage.....	6
Fig. 4: Output current and voltage under different load conditions .....	6
Fig. 5: Output voltage in dependence of output load current.....	6
Fig. 6: Voltage drop in parallel mode depending on the load current.....	6
Fig. 7: Inrush current and energy during start-up phase .....	7
Fig. 8: Conversion efficiency in dependence of the output power.....	8
Fig. 9: Power losses in dependence of the output power .....	8
Fig. 10: Cycle duration in dependence of the ambient temperature and usage of the full boost power (120% / 2s).....	8
Fig. 11: Input power factor in dependence of the output current.....	8
Fig. 12: Typical input current per phase in dependence of the load current .....	8
Fig. 13: Output power or ambient temperature derating at increasing altitudes .....	9
Fig. 14: Output power derating in dependence of the ambient temperature .....	9
Fig. 15: Power supply service lifetime in dependence of ambient temperature .....	10
Fig. 16: Generic diagram visualising failure rate and MTBF values during the products life-cycle .....	10
Fig. 17: Dimension drawing of DRB240-24-3-A0 .....	11
Fig. 18: Dimension drawing of DRB240-24-3-A1 .....	11
Fig. 19: Installation clearances in normal mounting position.....	12
Fig. 20: DC-OK relay characteristic in dependence of output voltage changes.....	13
Fig. 21: Control of the output voltage in dependence of the inhibit relay status.....	13
Fig. 22: Generic connection diagram of DC OK and INHIBIT contacts.....	13
Fig. 23: Functional block diagram .....	14
Fig. 24: Schematic of the insulation paths .....	15
Fig. 25: Connection scheme for paralleling n+1 power supplies .....	18
Fig. 26: Example scheme of wrong parallel wiring.....	18
Fig. 27: Example of a 480W application with limited redundancy .....	18
Fig. 28: Schematic of load sharing in PARALLEL mode if PSUs are adjusted to $U_{out\_nom} \pm 100mV$ .....	18
Fig. 29: Connection scheme for series operation with positive voltage level .....	19
Fig. 30: Connection scheme for series operation with negative voltage level.....	19
Fig. 31: Connection scheme for series operation with centre tap .....	19
Fig. 32: Connection diagram for 2-phase operation.....	20

**TDK-Lambda France SAS**

Tel: +33 1 60 12 71 65  
france@fr.tdk-lambda.com  
www.emea.lambda.tdk.com/fr

**Italy Sales Office**

Tel: +39 02 61 29 38 63  
info.italia@it.tdk-lambda.com  
www.emea.lambda.tdk.com/it

**Netherlands**

info@nl.tdk-lambda.com  
www.emea.lambda.tdk.com/nl

**TDK-Lambda Germany GmbH**

Tel: +49 7841 666 0  
info@de.tdk-lambda.com  
www.emea.lambda.tdk.com/de

**Austria Sales Office**

Tel: +43 2256 655 84  
info@at.tdk-lambda.com  
www.emea.lambda.tdk.com/at

**Switzerland Sales Office**

Tel: +41 44 850 53 53  
info@ch.tdk-lambda.com  
www.emea.lambda.tdk.com/ch

**Nordic Sales Office**

Tel: +45 8853 8086  
info@dk.tdk-lambda.com  
www.emea.lambda.tdk.com/dk

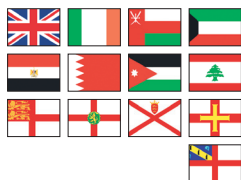
**TDK-Lambda UK Ltd.**

Tel: +44 (0) 12 71 85 66 66  
powersolutions@uk.tdk-lambda.com  
www.emea.lambda.tdk.com/uk

**TDK-Lambda Ltd.**

Tel: +9 723 902 4333  
info@tdk-lambda.co.il  
www.emea.lambda.tdk.com/il

**C.I.S.****Commercial Support:**

Tel: +7 (495) 665 2627

**Technical Support:**

Tel: +7 (812) 658 0463

info@tdk-lambda.ru

www.emea.lambda.tdk.com/ru

**TDK-Lambda Americas**

Tel: +1 800-LAMBDA-4 or 1-800-526-2324  
powersolutions@us.tdk-lambda.com  
www.us.lambda.tdk.com

**TDK Electronics do Brasil Ltda**

Tel: +55 11 3289-9599  
sales.br@tdk-electronics.tdk.com  
www.tdk-electronics.tdk.com/en

**TDK-Lambda Corporation**

Tel: +81-3-6778-1113  
www.jp.lambda.tdk.com

**TDK-Lambda (China) Electronics Co. Ltd.**

Tel: +86 21 6485-0777  
powersolutions@cn.tdk-lambda.com  
www.lambda.tdk.com.cn

**TDK-Lambda Singapore Pte Ltd.**

Tel: +65 6251 7211  
tts.mkt@sg.tdk-lambda.com  
www.sg.lambda.tdk.com

**TDK India Private Limited, Power Supply Division**

Tel: +91 80 4039-0660  
mathew.philip@in.tdk-lambda.com  
www.sg.lambda.tdk.com

For further information please visit:  
<https://www.emea.lambda.tdk.com/drb-3-phase>





**SCATTERGOOD  
& JOHNSON LTD**  
ELECTRICAL ENGINEERING & FLUID CONTROL DISTRIBUTORS

Est.1899

At Scattergood & Johnson Ltd, we pride ourselves on being a technical distributor to specialist industries.

Working with a range of quality product manufacturers across a number of specialist markets, we are not your average 'box shifter' - we are your technical and supply chain partner.

We fully support every product we sell - for free! Our internal team and external sales engineers can answer any product or application question, no matter the complexity.

Backing up this technical ability is a range of 50,000+ products available from stock for nationwide next day delivery (same day if required!), or you can collect what you need from any of our trade counters around the UK.

Select your specialist interest below to learn more about how we can help.

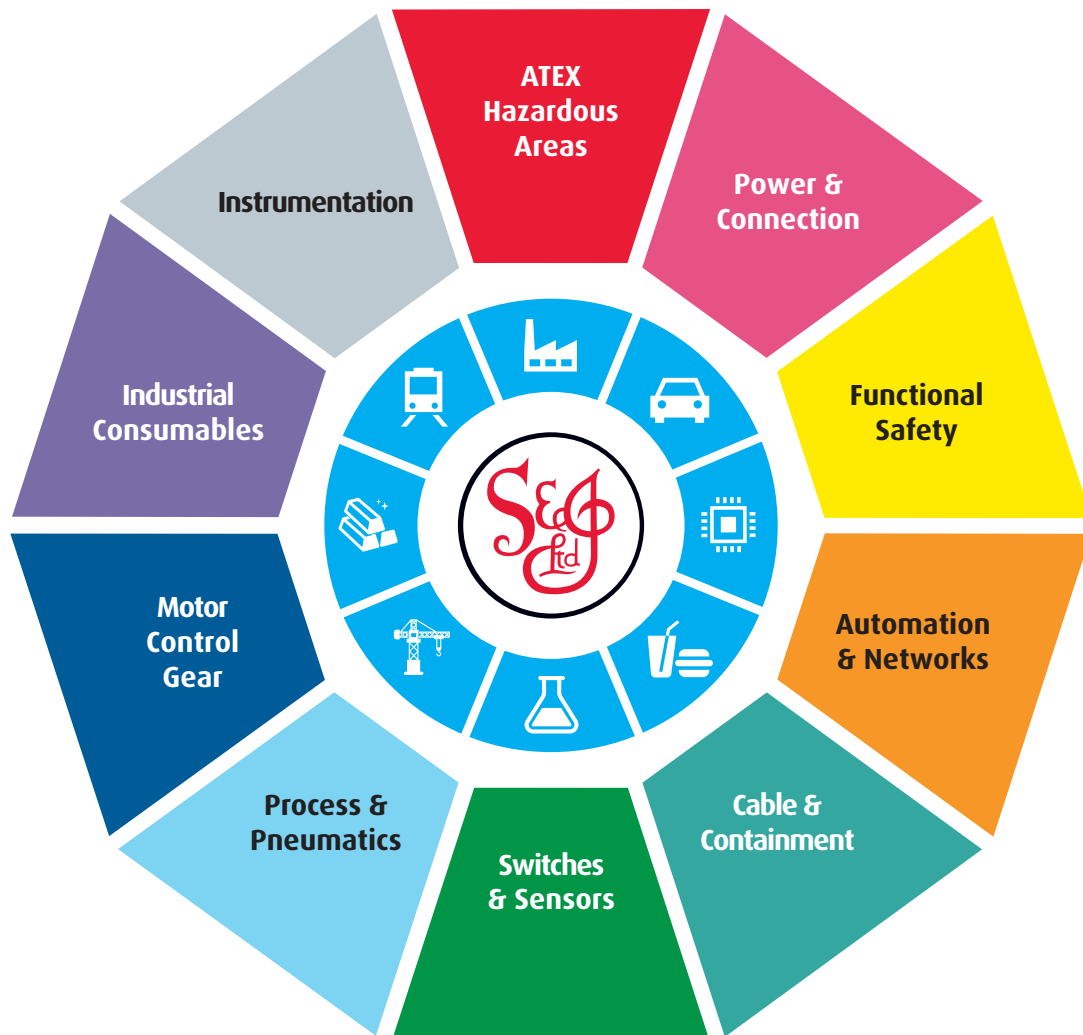

Online, In Branch and On the Road - Scattergood & Johnson Ltd, there when you need us.

**[www.scatts.co.uk](http://www.scatts.co.uk)**