

Instructions for BA3101 Pageant Operator Display

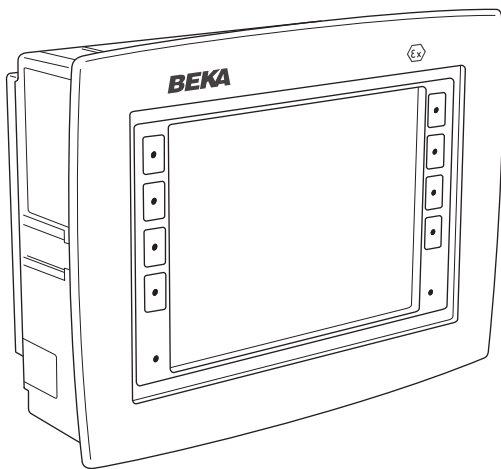

Issue 1
18th August 2022

BEKA associates Ltd. Old Charlton Rd, Hitchin, Hertfordshire, SG5 2DA, UK
Tel: +44(0)1462 438301 e-mail: sales@beka.co.uk
web: www.beka.co.uk

1. INTRODUCTION

The BA3101 is an IECEx, ATEX and UKCA certified intrinsically safe Operator Display. It is the core of the Pageant Operator Display System comprising a 7 inch backlit display with 8 touch buttons plus 8 sockets which can accommodate a single CPU module and up to 7 input and output modules.

The Operator Display and all of the plug-in modules are powered from a BEKA Power Isolator in the safe area or Zone 2 via a plug-in CPU (Central processing unit) module. The CPU module can also have external communications. Fig 1 shows the rear of the BA3101 Pageant Operator Panel with its features identified.

The BA3101 and all of the plug-in modules have individual intrinsic safety apparatus certificates. Compatible input and output safety parameters allow any certified BEKA plug-in Pageant CPU module to be fitted in display socket 'C'. Similarly, any certified BEKA plug-in Pageant input or output module may be fitted into sockets 1 to 7, providing the sum of the percentage power consumption of all the

modules fitted does not exceed 100%. See Pageant System Operator Panel instructions for further details.

Apart from an earth stud, all field connections to the BA3101 Pageant Operator Display are made via removable terminals on the plug-in modules.

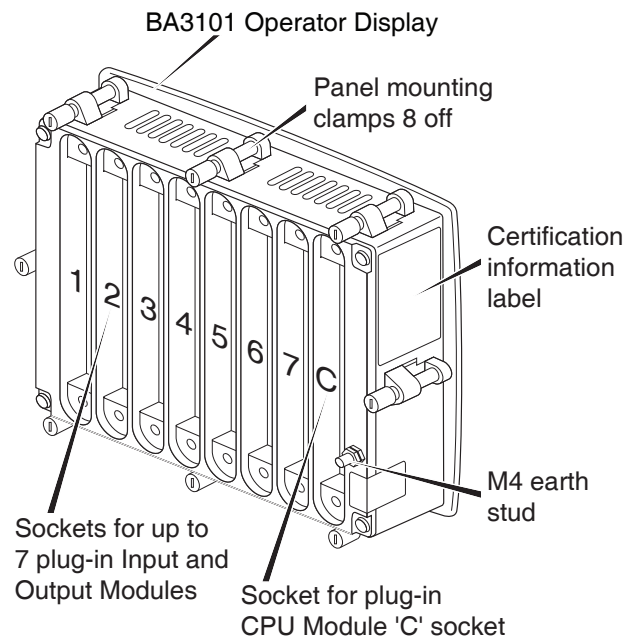

Fig 1 Rear view without plug-in modules

2. INTRINSIC SAFETY CERTIFICATION

Notified Body CML B.V. and UK Approved Body Eurofins CML have issued the BA3101 Pageant Operator Display with the following apparatus certificates:

IECEX	IECEX CML 20.0150X
ATEX	CML 20ATEX2252X
UKCA	CML21UKEX2003

The ATEX certificate confirms compliance with harmonised European standards and this has been used to confirm compliance with the European ATEX Directive for Group II, Category 1G and 1D equipment. The BA3101 Operator Display carries both the CE and UKCA marks, subject to local codes of practice, it may be installed in any of the European Economic Area (EEA) member countries and in the UK. ATEX certificates are also acceptable for installations in some non EU countries.

These instructions describe IECEx, ATEX and UKCA installations which conform with IEC / EN 60079-14 Electrical installations design, selection and erection. When designing systems the local code of practice should be consulted.

The BA3101 Pageant Operator Display is CE marked to show compliance with the *European Explosive Atmospheres Directive 2014/34/EU* and the *European EMC Directive 2014/30/EU*.

The BA3101 is also UKCA marked to show compliance with UK statutory requirements *Equipment and Protective Systems Intended for Use in Potentially Explosive Atmospheres Regulations UKSI 2016:1107 (as amended)* and with the *Electromagnetic Compatibility Regulations UKSI 2016:1091*.

2.1 Gas atmospheres - Zones, gas groups and T rating

All of the BA3101 Operator Display certifications specify the same gas code:

Ex ia IIC T4 Ga $-40^{\circ}\text{C} \leq T_a \leq 65^{\circ}\text{C}$

The Operator Display has no external connections, the only input and output intrinsic safety parameters are for the plug-in modules. It is therefore only necessary for the specifier and installer to ensure that all the plug-in modules are manufactured by BEKA and are certified for use with a BA3101 Pageant Operator Display.

When fitted with a certified BEKA plug-in CPU module and certified BEKA plug-in input and output modules, the BA3101 may be installed in:

Zone 0	explosive gas air mixture continuously present. Unlikely requirement
Zone 1	explosive gas air mixture likely to occur in normal operation.
Zone 2	explosive gas air mixture not likely to occur, and if it does will only exist for a short time.

Be used with gases in groups:

Group A	propane
Group B	ethylene
Group C	hydrogen

In gases that may be used with equipment having a temperature classification of:

T1	450°C
T2	300°C
T3	200°C
T4	135°C

At an ambient temperature T_a between -40°C and $+65^{\circ}\text{C}$

2.2 Dust atmospheres - Zones

All of the BA3101 Operator Display certifications specify the same dust code:

Ex ia IIIC T135°C Da $-40^{\circ}\text{C} \leq T_a \leq 65^{\circ}\text{C}$.

For applications in dust atmospheres, the certificates specify Special Conditions of Use (See section 2.3) which require the rear of the Operator Panel to have additional protection. This requirement can be satisfied by mounting the BA3101 Operator Display in a component certified Ex e enclosure with cable glands providing a minimum IP5X sealing.

When fitted with a certified BEKA plug-in CPU module and certified BEKA plug-in input and output modules, the BA3101 may be installed in:

Zone 20	explosive atmosphere in the form of a cloud of combustible dust in air is continuously present, or for long periods or frequently.
Zone 21	explosive atmosphere in the form of a cloud of combustible dust in air is likely to occur occasionally in normal operation.
Zone 22	explosive atmosphere in the form of a cloud of combustible dust in air is not likely to occur in normal operation, but if it does occur, will only persist for a short period.

Be used with dust in subdivisions:

IIIA	combustible flyings
IIIB	non-conductive dust
IIIC	conductive dust

2.3 Special conditions for safe use

All three certificate numbers have an 'X' suffix indicating that special conditions apply, please see certificates.

- Under certain extreme circumstances, the non-metallic parts incorporated in the enclosure of this equipment may generate an ignition-capable level of electrostatic charge. Therefore, the equipment shall not be installed in a location where the external conditions are conducive to the build-up of electrostatic charge on such surfaces. In addition, the equipment shall only be cleaned with a damp cloth.
- The metal bezel of the equipment shall be connected to earth via the integral earth stud.
- In installations requiring EPLs Da, Db, or Dc, the surface temperature assigned to this equipment shall take precedence over the surface temperature assigned to any plug-in module which may be installed within its enclosure.
- In installations requiring EPL Da, Db, or Dc, the equipment shall be mounted to an enclosure which provides a minimum degree of protection of IP5X and which meets the requirements of EN60079-0 Clause 8.4 (material composition requirements for metallic enclosures for Group III) and/or EN60079-0 Clause 7.4.3 (Avoidance of a build up of electrostatic charge for Group III) as appropriate.

All cable entries into the equipment shall be made via cable glands which provided a minimum degree of protection of IP5X

2.4 Certification label information

The certification information label is fitted to the side of the Pageant Operator Display. It shows the model number, certification information and BEKA associates address and year of manufacture together with the serial number.



Certification Information Label

3. INSTALLATION

3.1 Location

The BA3101 Pageant Operator Display has a 316 stainless steel front panel surrounding the backlit display which is protected by a 4mm thick toughened glass window. The front of the Operator Display has IP66 protection and a silicone moulded gasket provides an IP66 seal to the instrument panel. The rear of the BA3101 Pageant Operator Display has IP20 protection.

The BA3101 may be installed in any panel providing the environmental and safety limits shown in the specification are not exceeded.

Fig 2 shows the overall dimensions of the BA3101 including the plug-in modules and the panel cut-out.

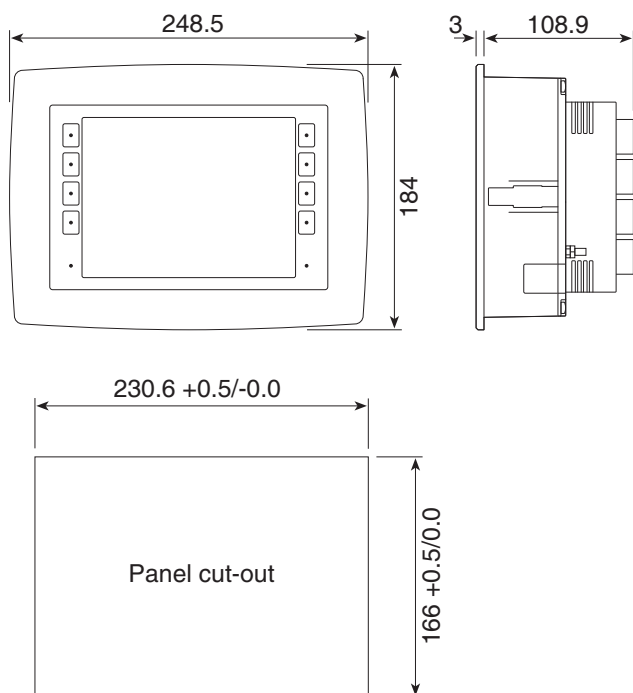

Fig 2 BA3101 dimensions including plug-in modules and panel cut-out

3.2 BA3101 Operator Display Installation Procedure

1. Cut the aperture specified in Fig 2 in the panel and ensure that all edges are de-burred.
2. First ensure that all eight panel mounting clamps are closed by turning the knurled screws fully anticlockwise until the two pips in the clamp foot align with holes in the clamp body as shown in Fig 3.
3. Ensure that the panel sealing gasket is correctly positioned before inserting the BA3101 Operator Display into the panel aperture.
4. Place a clamp in the recess on each side of the BA3101, pulling gently to slide it onto the dovetail as shown in Fig 3. Push the knurled screw slightly forward to engage the thread and tighten by turning clockwise until it is just finger tight. When both clamps are fitted ensure that the gasket behind the front panel bezel remains correctly positioned before fitting the remaining panel mounting clamps. Finally, fully tighten all the panel clamps to secure the instrument. The maximum recommended clamp tightening torque is 22cNm (1.95 lbf in) which is approximately equivalent to finger-tight plus one half turn. Do not over tighten.

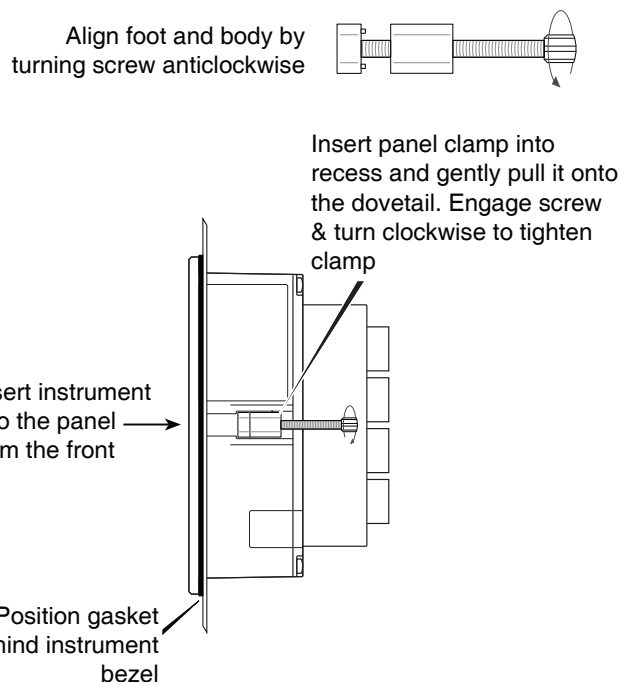

Fig 3 Installation of panel and mounting clamps

4. PLUG-IN MODULES

The BA3101 Operator Panel can accommodate one plug-in CPU module in the right hand socket, marked 'C' and up to seven plug-in input or output modules in the remaining sockets marked 1 to 7 as shown in Fig 1. Modules have keyed plugs and sockets which ensure that an input or output module can not be fitted in the 'C' socket and a CPU module can not be fitted in sockets marked 1 to 7.

All BA3101 Operator Displays must be fitted with a plug-in CPU module which contains the central processing unit and memory. It also distributes power to the display and to all of the plug-in input and output modules from a BEKA Power Isolator located in the safe area or in Zone 2. Some CPU modules also include an external communication port.

Input and output modules may be fitted in any of the seven sockets most convenient for field wiring, they do not have to be installed in a specific position or order, but their position does have to be entered in the application software.

4.1 Installing a plug-in module

All Pageant plug-in modules are installed in the same way and may be fitted before or after the Operator Display is mounted in a panel or cubicle. The Operator Display should not be powered while a plug-in module is being inserted or removed.

For a hazardous area installation plug-in modules must be manufactured by BEKA and have certification that specifies that they shall be used as part of a BEKA Pageant system.

5. FIELD WIRING

All field connections to the BA3101 Operator Panel are made via the removable terminals on the plug-in modules which are described in the instructions supplied with each module. Apart from the earth stud, there are no direct field connections to the BA3101 Pageant Operator Display.

The M4 earth stud is located on the right hand side at the rear of the Operator Panel as shown in Fig 1. It should be connected to earth and to the metallic structure of the enclosure in which the BA3101 Pageant Operator Panel is mounted.

To simplify installation all module field wiring terminals are removable by gently pulling. Wiring should be supported to prevent damage to the connectors, particularly in installations subject to vibration.

6. ACCESSORIES

6.1 Tag number

The BA3101 Pageant Operator Panel can be identified by a tag number or application information thermally printed on a self-adhesive label fitted to the side of the instrument.

7. MAINTENANCE

The BA3101 Operator Display should be regularly inspected to ensure that it has not been damaged. The frequency of inspections depends upon the environmental conditions.

No attempt should be made to repair a faulty BA3101 Pageant Operator Panel. Suspect Operator Panels should be returned to BEKA associates or your local BEKA agent.

8. GUARANTEE

Operator Displays which fail within the guarantee period should be returned to BEKA associates or your local BEKA agent. It is helpful if a brief description of the fault symptom(s) is provided.

9. CUSTOMER COMMENTS

BEKA associates are always pleased to receive comments from customers about our products and services. All communications are acknowledged and whenever possible, suggestions are implemented.

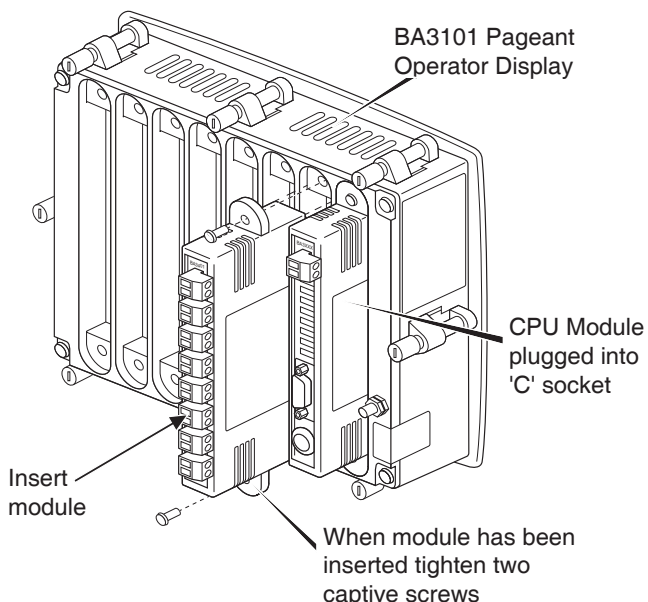

Fig 4 Installing plug-in modules



All associated manuals, certificates, and datasheets can be downloaded from https://www.beka.co.uk/qr-ba3101_1

BEKA associates

Old Charlton Rd, Hitchin, Hertfordshire, SG5 2DA, UK
Tel: +44(0)1462 438301 e-mail: sales@beka.co.uk
web: www.beka.co.uk



SCATTERGOOD & JOHNSON LTD

ELECTRICAL ENGINEERING & FLUID CONTROL DISTRIBUTORS

Est.1899

At Scattergood & Johnson Ltd, we pride ourselves on being a technical distributor to specialist industries.

Working with a range of quality product manufacturers across a number of specialist markets, we are not your average 'box shifter' - we are your technical and supply chain partner.

We fully support every product we sell - for free! Our internal team and external sales engineers can answer any product or application question, no matter the complexity.

Backing up this technical ability is a range of 50,000+ products available from stock for nationwide next day delivery (same day if required!), or you can collect what you need from any of our trade counters around the UK.

Select your specialist interest below to learn more about how we can help.



Online, In Branch and On the Road - Scattergood & Johnson Ltd, there when you need us.

www.scatts.co.uk