

**IO-Link**



657 0x0 55  
657 1x0 55

657 5x0 55  
657 6x0 55



657 1x0 55  
657 6x0 55



**DE** HINWEIS: Benutzung bei >50 °C kann zu einer signifikanten Reduzierung der Helligkeit und der Lebensdauer führen.

**GB** NOTE: Usage at >50 °C can result in significant loss of light intensity and life duration.

**FR** REMARQUE : Une utilisation à >50 °C peut réduire considérablement la brillance et la durée de vie.

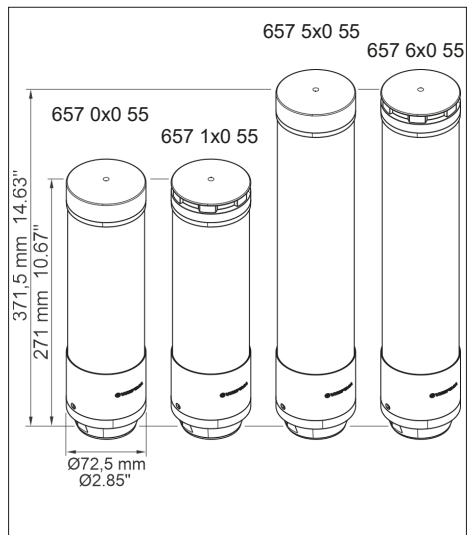

© DE



WERMA Signaltechnik GmbH + Co. KG  
D-78604 Riethem-Weilheim  
Telefon +49 (0)7424 / 9557-0  
Telefax +49 (0)7424 / 9557-44  
info@werma.com  
www.werma.com



**DE** Anschluss **ausschließlich** durch ausgebildete Elektro-Fachkräfte.

**GB** Electrical connection is to be made by trained electrical specialists **only**.

**FR** Le branchement doit **uniquement** être effectué par des professionnels.

**IT** Il collegamento deve essere eseguito **solo** da elettricisti specializzati.

**ES** La conexión **sólo** debe ser realizada por electricistas debidamente formados.

**PT** A ligação deve ser feita **exclusivamente** por profissional elétrico especializado.

**NL** De aansluiting mag **enkel** gebeuren door erkende vakmensen.

**CZ** Připojení smí **provádět** pouze kvalifikovaný personál.

**PL** Podłączenie **wyłącznie** przez specjalistów-elektryków.

**FI** Liittäminen kuuluu **ainoastaan** koulutettujen sähköalan ammattilaisten tehtävin.

**RU** Подключение проводится только специалистами-электриком.

**TR** Bağlantı **sadece** eğitimli elektrik teknisyenleri tarafından yapılmalıdır.

**CN** 布线需由专业电工执行。



1) - 3): Type 12/13/4X

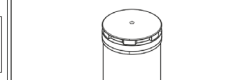
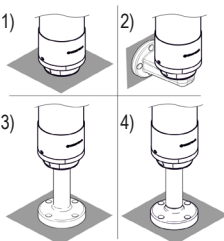

**DE** Die Quelle für begrenzte Spannung/Stromstärke muss die folgenden Anforderungen erfüllen: Eine geeignete isolierende Stromversorgung in Verbindung mit einer Sicherung gemäß UL248, (JDYX2/8). Die Sicherung muss auf einen Nennwert von max. T2,5 A ausgelegt sein und in der 24-V-Gleichstromversorgung des Geräts installiert werden, um den verfügbaren Strom zu begrenzen.

**GB** The Limited Voltage / Current source must comply with following:  
A suitable isolating source in conjunction with a fuse in accordance with UL248, (JDYX2/8). The fuse shall be rated max. T2.5 A and be installed in the 24 Vdc power supply to the device in order to limit the available current.

**FR** La source de tension/courant limitée doit être conforme à ce qui suit :  
Une alimentation isolée adaptée, associée à un fusible conforme à la norme UL248, (JDYX2/8). Le fusible doit avoir une valeur nominale de 2,5 A maximum et être installé dans l'alimentation 24 V DC de l'appareil afin de limiter le courant disponible.

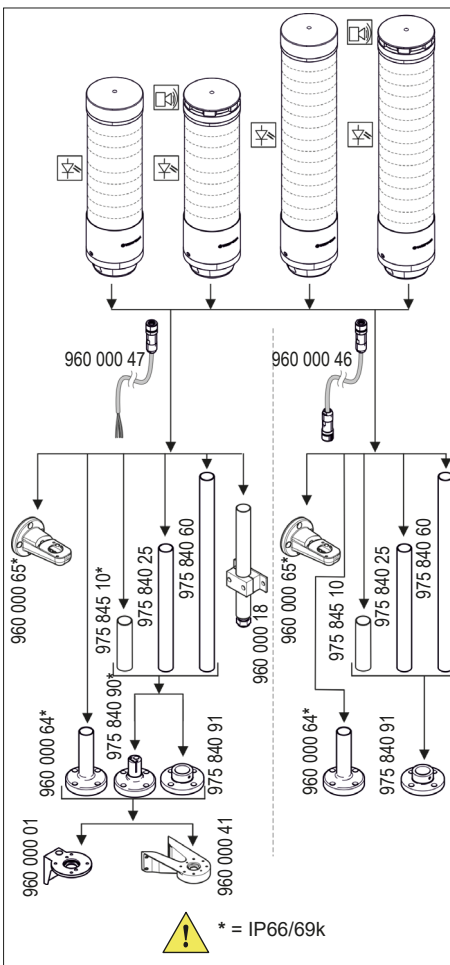

\* = IP66/69k

	eSIGN <b>IO-Link</b>
657 010 55	24 V=, I=335 mA, I <sub>0</sub> =800 mA
657 110 55	24 V=, I=405 mA, I <sub>0</sub> =800 mA
657 510 55	24 V=, I=555 mA, I <sub>0</sub> =800 mA
657 610 55	24 V=, I=620 mA, I <sub>0</sub> =800 mA

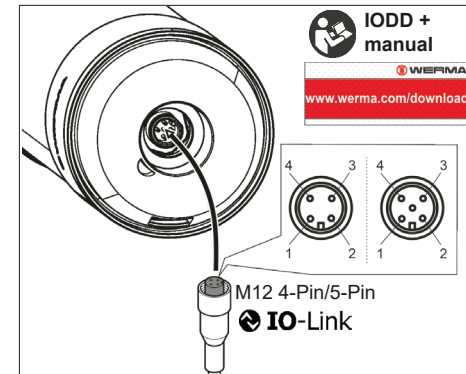

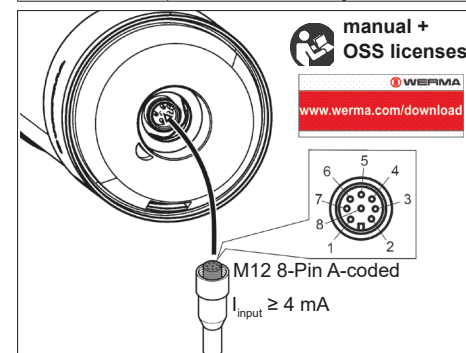

M12 pin	eSIGN <b>IO-Link</b>
1	L+
2	+24 V (optional)
3	L-
4	C/Q

	eSIGN 24 V
657 000 55	24 V=, I=335 mA, I <sub>0</sub> =800 mA
657 100 55	24 V=, I=405 mA, I <sub>0</sub> =800 mA
657 500 55	24 V=, I=555 mA, I <sub>0</sub> =800 mA
657 600 55	24 V=, I=620 mA, I <sub>0</sub> =800 mA



Pin	Wire color	Function
1	WH	Input 1
2	BN	Input 2
3	GN	Input 3
4	YE	Input 4

Pin	Wire color	Function
5	GY	Input 5
6	PK	Input 6
7	BU	COM
8	RD	+24 V

 

**+ Configuration Software**

**Download** [www.werma.com/software](http://www.werma.com/software)

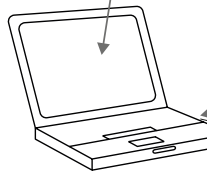
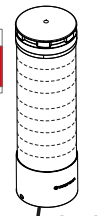
**2.**  

**1.** 960 000 69  **min. 500 mA** **USB-C**

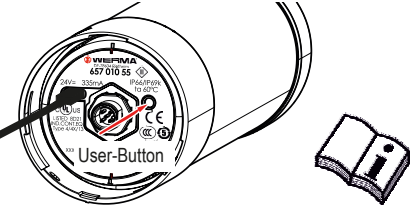

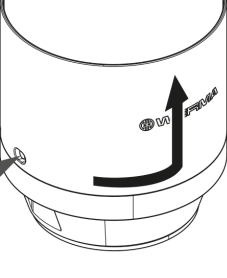

**1**

Nur falls verriegelt!  
Only if locked!  
Seulement si verrouillé!

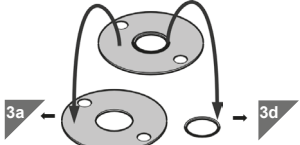

**2a**



**2b**  **nur only**  
**seulement**

Sollbruchstellen durchstechen!  
Pierce knockouts!  
Percez les points de rupture!

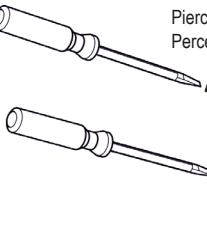
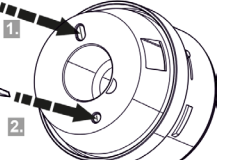

**3**

3a: 657 xx0 55  
3b: 657 xx0 55 + 960 000 65  
3c: 657 xx0 55 + 960 000 01  
3d: 657 xx0 55 + 960 000 64  
+ 975 840 90 + 975 845 10, ...  
+ 975 840 91 + 975 845 10, ...  
3e: 657 xx0 55 + 960 000 41

**3a**

\*\* Platzbedarf für Stecker bei der Installation berücksichtigen!  
When installing the product: Ensure enough space is left for the plug!  
Tenez compte de l'espace requis pour les prises lors de l'installation!

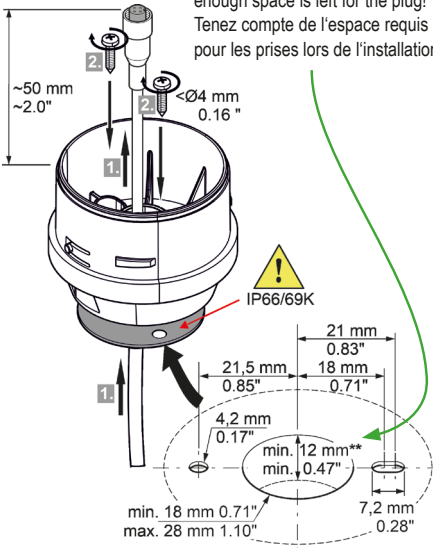

~50 mm ~2.0"  $\leq \varnothing 4$  mm 0.16"

IP66/69K

21 mm 0.83"  $\leq \varnothing 5$  mm 0.20"

21.5 mm 0.85" 18 mm 0.71" 4.2 mm 0.17" min. 12 mm\*\* min. 0.47" 7.2 mm 0.28" min. 18 mm 0.71" max. 28 mm 1.10"

**3b**

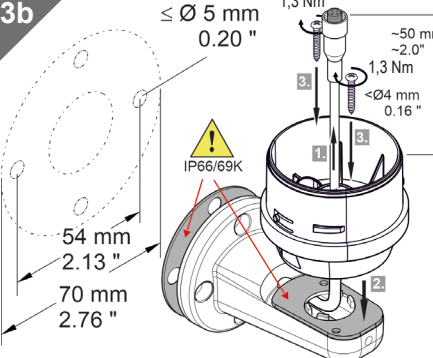

$\leq \varnothing 5$  mm 0.20" 1.3 Nm ~50 mm ~2.0" 1.3 Nm  $\leq \varnothing 4$  mm 0.16"

IP66/69K

54 mm 2.13" 70 mm 2.76"

**3c**

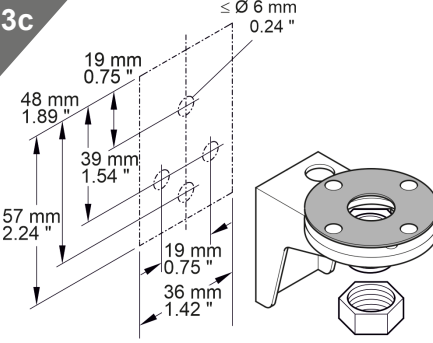

$\leq \varnothing 6$  mm 0.24" 19 mm 0.75" 48 mm 1.89" 39 mm 1.54" 57 mm 2.24" 19 mm 0.75" 36 mm 1.42"

**3d**

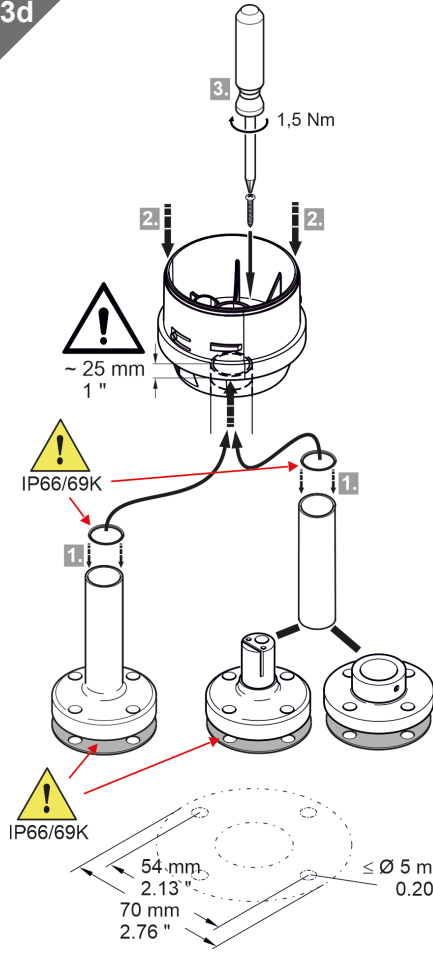

1.5 Nm  $\sim 25$  mm 1" IP66/69K

IP66/69K

IP66/69K

54 mm 2.13" 70 mm 2.76"  $\leq \varnothing 5$  mm 0.20"

**3e**

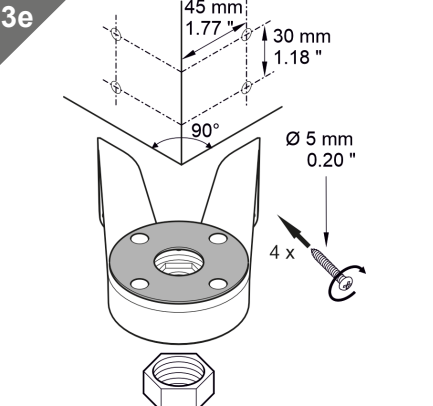

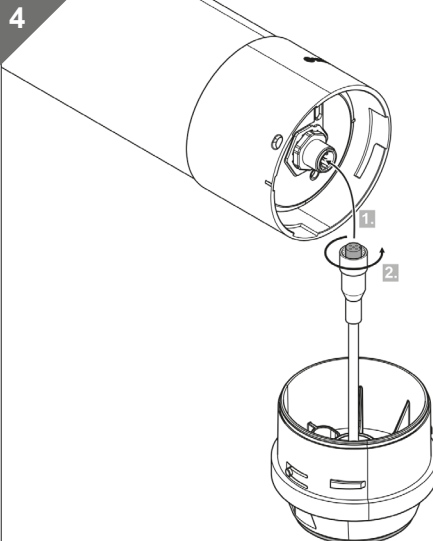

45 mm 1.77" 30 mm 1.18" 90°  $\varnothing 5$  mm 0.20" 4 x 

**4**

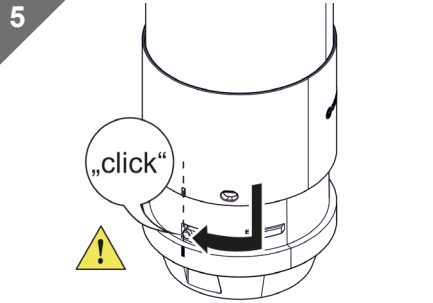

**5**



"click" 

15000002733\_AC  
310.657.001

 © DE



**SCATTERGOOD  
& JOHNSON LTD**  
ELECTRICAL ENGINEERING & FLUID CONTROL DISTRIBUTORS

Est.1899

At Scattergood & Johnson Ltd, we pride ourselves on being a technical distributor to specialist industries.

Working with a range of quality product manufacturers across a number of specialist markets, we are not your average 'box shifter' - we are your technical and supply chain partner.

We fully support every product we sell - for free! Our internal team and external sales engineers can answer any product or application question, no matter the complexity.

Backing up this technical ability is a range of 50,000+ products available from stock for nationwide next day delivery (same day if required!), or you can collect what you need from any of our trade counters around the UK.

Select your specialist interest below to learn more about how we can help.



Online, In Branch and On the Road - Scattergood & Johnson Ltd, there when you need us.

**[www.scatts.co.uk](http://www.scatts.co.uk)**