

eX700M Series

Operating Instructions



Copyright © 2022 Exor International S.p.A. – Verona, Italy
Subject to change without notice

The information contained in this document is provided for informational purposes only. While efforts were made to verify the accuracy of the information contained in this documentation, it is provided “as is” without warranty of any kind.

Third-party brands and names are the property of their respective owners.

www.exorint.com

Software available in these products is based on OpenSource. Visit oss.exorint.net for more details.

MANUGENEX7xxM - Version 1.00

© 2022 EXOR International S.p.A. - Subject to change without notice



Table of Contents

Introduction	4
Safety Guide	5
1 Product Overview	6
2 Standards and Approvals	7
3 Technical Specifications	9
4 Technical Data	11
4.1 Dimensions	13
4.2 Installation Environment	16
4.3 Safety instruction	16
4.4 Installation Procedure	16
5 Connections	17
5.1 Serial Port	19
5.2 Ethernet Port	19
5.3 Optional plugin module	20
5.4 Optional plugin module identification	21
5.5 Optional plugin module installation procedure	22
6 Power Supply, Grounding and Shielding	25
7 Battery	26
8 Special Instruction for Use	27
9 Getting Started	27
10 Unpacking and Packing Instructions	28



Introduction

The operational guidelines described below is information which relates to the device, installation, transportation, storage, assembly, use and maintenance.

This Operating Instruction describes the main features of the Exor operator panels. The manual refers to the following models:

Model	Part Number	Description
eX705M	EX705MU5P1	HMI 5" TFT 800x480, PCAP Touch, 8 GB Flash Memory, 2x Ethernet, JMobile runtime
eX707M	EX707MU5P1	HMI 7" TFT 800x480, PCAP Touch, 8 GB Flash Memory, 3x Ethernet, JMobile runtime
eX710M	EX710MU5P1	HMI 10" TFT, 1280x800, PCAP Touch, 8 GB Flash Memory, 3x Ethernet, JMobile runtime
eX712M	EX712MU5P1	HMI 12" TFT, 1920x720, PCAP Touch, 8 GB Flash Memory, 3x Ethernet, JMobile runtime
eX715M	EX715MU5P1	HMI 15" TFT, 1366x768, PCAP Touch, 8 GB Flash Memory, 3x Ethernet, JMobile runtime
eX721M	EX721MU5P1	HMI 21" TFT, 1920x1080, PCAP Touch, 8 GB Flash Memory, 3x Ethernet, JMobile runtime
eX705M	EX705MU5PW	Web HMI 5" TFT 800x480, PCAP Touch, 8 GB Flash Memory, 2x Ethernet, Web browser
eX707M	EX707MU5PW	Web HMI 7" TFT 800x480, PCAP Touch, 8 GB Flash Memory, 3x Ethernet, Web browser
eX710M	EX710MU5PW	Web HMI 10" TFT, 1280x800, PCAP Touch, 8 GB Flash Memory, 3x Ethernet, Web browser
eX712M	EX712MU5PW	Web HMI 12" TFT, 1920x720, PCAP Touch, 8 GB Flash Memory, 3x Ethernet, Web browser
eX715M	EX715MU5PW	Web HMI 15" TFT, 1366x768, PCAP Touch, 8 GB Flash Memory, 3x Ethernet, Web browser
eX721M	EX721MU5PW	Web HMI 21" TFT, 1920x1080, PCAP Touch, 8 GB Flash Memory, 3x Ethernet, Web browser



Safety Guide

The manual contains safety standards that must be respected for the personal safety and to avoid damage. Indications of attention are divided into three levels of severity:

DANGER: indicates a failure to observe safety rules and such failure may cause death or serious injuries.



DANGER

ATTENTION: indicates a failure to observe safety rules and that deficiency may cause damage.



ATTENTION

CAUTION: indicates a failure to observe safety rules and that deficiency may cause defects to the equipment or inconsistencies.



CAUTION



1 Product Overview

eX700M Series HMI products combine state-of-the-art connectivity features and top performance in a great design. Products have been designed as IoT edge devices with the combination of a powerful controller with networking capability and outstanding communication options including client/server OPC UA. They are the ideal choice for all demanding IoT edge applications in factory, marine and building automation.

The glass projected capacitive touchscreen and the brilliant displays with size up to 21.5" and resolution up to 1920x1080 guarantee great optical performance; with the support of multitouch gesture programming they can create the most natural human interfaces.

eX700M HMI products have been designed to run the JMobile software.

eX700M Web version HMI products combine state-of-the-art connectivity features and top browsing performance in a great design. They are the ideal choice for all demanding IoT edge applications in factory, marine and building automation where powerful and performing HTML5 web browser is needed.

eX700M Web version HMI products include a Chromium based HTML5 browser supporting kiosk mode operation. Supports Corvina Cloud secure connectivity with full network separation.

- Chromium based HTML5 Browser
- Easy to use browser setting application



2 Standards and Approvals

The products have been designed for use in an industrial environment in compliance with the 2014/30/EU EMC Directive.

The products have been designed in compliance with:

EN 61000-6-4 CISPR 22 Class A
CISPR 16-2-3

EN 61000-6-2 EN 61000-4-2
EN 61000-4-3
EN 61000-4-4
EN 61000-4-5
EN 61000-4-6
EN 61000-4-8
EN 61000-4-11
EN 61000-4-29

EN60945

IECEX IECEX: IECEX ULD 17.0019X
IEC 60079-0 Ex ec IIC T5...T4 Gc -20°C≤Tamb≤+60°C or 0°C≤Tamb≤+50°C
IEC 60079-7 Ex tc IIIC T95°C Dc
IEC 60079-31

ATEX DEMKO 17 ATEX 1871X
EN IEC 60079-0  II 3G Ex ec IIC T5...T4 Gc -20°C≤Tamb≤+60°C or 0°C≤Tamb≤+50°C
EN IEC 60079-7+A1 II 3D Ex tc IIIC T95°C Dc
CENELEC EN 60079-31

The installation of these devices into the residential, commercial and light-industrial environments is allowed only in the case that special measures are taken in order to ensure conformity to EN 61000-6-3.

The products are in compliance with the Restrictions on Certain Hazardous Substances (RoHS) Directive 2011/65/EU

In compliance with the above regulations the products are CE marked.

Products described in this manual may have other approvals and certificates.
Please refer to product datasheets available at www.exorint.com



2 Standards and Approvals

Product Identification

The product may be identified through a plate attached to the rear cover. You will have to know the type of unit you are using for correct usage of the information contained in the guide.

An example of this plate is shown in the figure below:

Note: the eX707M label is used as an example for eX700M Series and eX700M Web version.



product model name	eX707M
product part number	EX707MU5P1
year/week of production	1816
serial number	AA00011FT000000561AA
version id of the product	120408A04002000
manufacturer address	Exor International S.p.A. Via Monte Fiorino 9 IT-37057 San Giovanni Lupatoto (VR)
ATEX Marking	 DEMKO 17 ATEX 1871X II 3G Ex ec IIC T5...T4 Gc 0°C ≤ Tamb ≤ +50°C or -20°C ≤ Tamb ≤ +60°C II 3D Ex tc IIIC T95°C Dc
IECEX Marking	IECEX: IECEX ULD 17.0019X Ex ec IIC T5...T4 Gc 0°C ≤ Tamb ≤ +50°C or -20°C ≤ Tamb ≤ +60°C Ex tc IIIC T95°C Dc



3 Technical Specifications

Touchscreen technology	Projected capacitive
Back-up battery	3V 50mAh Lithium, rechargeable, not user-replaceable, model VL2330.
Fuse	Automatic
Serial Port	RS-232, RS-485, RS-422 software configurable
Flash	8GB
RAM	2GB
Hardware clock	Clock/Calendar with back-up battery
Accuracy RTC (at 25°C)	<100ppm

Environmental conditions

Operating temperature (surrounding air temperature)	-20 ÷ +60°C (vertical installation) Plug-in modules and USB devices may limit max temperature to +50°C	EN 60068-2-14
Storage temperature	-20 ÷ +70°C	EN 60068-2-1 EN 60068-2-2 EN 60068-2-14
Operating and storage humidity	5 ÷ 85 % RH non-condensing	EN 60068-2-30
Vibrations	5 ÷ 9 Hz, 7 mm _{p-p} 9 ÷ 150 Hz, 1 g	EN 60068-2-6
Shock	± 50 g, 11 ms, 3 pulses per axis	EN 60068-2-27
Protection class	Front panel IP66, Rear IP20	EN 60529

Electromagnetic Compatibility (EMC)

Radiated disturbance test	Class A	CISPR 22 CISPR 16-2-3
Electrostatic discharge immunity test	8 kV (air electrostatic discharge) 4 kV (contact electrostatic discharge)	EN 61000-4-2
Radiated, radio-frequency, electromagnetic field immunity test	80 MHz ÷ 1 GHz, 10V/m 1,4 GHz ÷ 2 GHz, 3 V/m 2 GHz ÷ 2.7 GHz, 1 V/m	EN 61000-4-3
Burst immunity test	± 2 kV dc power port ± 1 kV signal line	EN 61000-4-4
Surge immunity test	± 0,5 kV dc power port (line to earth) ± 0,5 kV dc power port (line to line) ± 1 kV signal line (line to earth)	EN 61000-4-5
Immunity to conducted disturbances induced by radiofrequency field	0.15 ÷ 80 MHz, 10V	EN 61000-4-6
Power frequency magnetic field immunity test	Enclosure, 50/60Hz, 30A/m	EN 61000-4-8



3 Technical Specifications

Voltage dips, short interruptions and voltage variations immunity test

Port: AC mains; Level:	
100% duration:	1 cycle and 250 cycles (50Hz); 1 cycle and 300 cycles (60Hz);
40% duration:	10 cycles (50Hz); 12 cycles (60Hz);
70% duration:	25 cycles (50Hz); 30 cycles (60Hz);
Phase: 0°-180°	

Test executed on the 230Vac side of the Exor International S.p.A. Power Supply EN 61000-4-11

Port: DC mains; Level:	
0% duration:	10ms 20 spaces by 1s

Test executed on the 24Vdc of the EUT EN 61000-4-29

Durability information

Backlight service life (LED type)

40000 Hrs. or more
(Time of continuous operation until the brightness of the backlight reaches 50% of the rated value when the surrounding air temperature is 25°C) - see Note 1

Note 1: Extended use in environments where the surrounding air temperature is 40°C or higher may degrade backlight quality/reliability/durability.

Surface resistance

Chemical resistance of the front glass for an exposure time of 24 hours without visible changes:

- Betadine (10% Povidone Solution)
- Cola
- Electrode Gel/Paste
- Hydrogen Peroxide (3% Solution)
- NaCl (0.9% Solution)
- Coffee
- Dextrose (5% Glucose Solution)
- Hydrogen chloride (0.5% Solution PH=1)
- Isopropyl Alcohol
- Sodium Hypochlorit
- Ethyl Alcohol (70%-90%)
- Quaternary ammonium compound



4 Technical Data

Model	eX705M	eX707M	eX710M
Display / Backlight	TFT Color / LED	TFT Color / LED	TFT Color / LED
Colors	64K	16M	16M
Resolution	800X480	800X480	1280X800
Diagonal (inches)	5" widescreen	7" widescreen	10.1" widescreen
Dimming	yes	yes	yes
CPU	64-bit RISC quad core - 1.6GHz	64-bit RISC quad core - 1.6GHz	64-bit RISC quad core - 1.6GHz
Operating System	Linux	Linux	Linux
Flash	8GB	8GB	8GB
RAM	2GB	2GB	2GB
Real Time Clock	yes	yes	yes
Ethernet port	2 10/100Mb	2 10/100Mb, 1 10/100/1000Mb	2 10/100Mb, 1 10/100/1000Mb
USB port	1 Host interface version 2.0 max. 500mA	2 Host interface version 2.0 max. 500mA	2 Host interface version 2.0 max. 500mA
Serial Port	RS-232,RS-485, RS-422 software configurable	RS-232,RS-485, RS-422 software configurable	RS-232,RS-485, RS-422 software configurable
SD card slot	yes	yes	yes
Expansion slot	1 Optional Plugin	2 Optional Plugin	2 Optional Plugin
Voltage	24Vdc (*)	24Vdc (*)	24Vdc (*)
Current rating (at 24VDC)	0.6A	0.7A	1.00A
Battery	rechargeable	rechargeable	rechargeable
Weight	1 Kg	1.3 Kg	1.7 Kg

(*) 10-32Vdc

For applications requiring compliance with EN 61131-2 and specifically in reference to 10 ms voltage dips (according to EN 61000-4-29), the lower power supply voltage limit is 20,4Vdc.



4 Technical Data

Model	eX712M	eX715M	eX721M
Display / Backlight	TFT Color / LED	TFT Color / LED	TFT Color / LED
Colors	16M	16M	16M
Resolution	1920x720	1366X768	1920X1080
Diagonal (inches)	12.3" widescreen	15.6" widescreen	21.5" widescreen
Dimming	yes	yes	yes
CPU	64-bit RISC quad core - 1.6GHz	64-bit RISC quad core - 1.6GHz	64-bit RISC quad core - 1.6GHz
Operating System	Linux	Linux	Linux
Flash	8GB	8GB	8GB
RAM	2GB	2GB	2GB
Real Time Clock	yes	yes	yes
Ethernet port	2 10/100Mb, 1 10/100/1000Mb	2 10/100Mb, 1 10/100/1000Mb	2 10/100Mb, 1 10/100/1000Mb
USB port	2 Host interface version 2.0 max. 500mA	2 Host interface version 2.0 max. 500mA	2 Host interface version 2.0 max. 500mA
Serial Port	RS-232, RS-485, RS-422 software configurable	RS-232,RS-485, RS-422 software configurable	RS-232,RS-485, RS-422 software configurable
SD card slot	yes	yes	yes
Expansion slot	2 Optional Plugin	2 Optional Plugin	2 Optional Plugin
Voltage	24Vdc (*)	24Vdc (*)	24Vdc (*)
Current rating (at 24VDC)	1.10A	1.20A	1.70A
Battery	rechargeable	rechargeable	rechargeable
Weight	1.8 Kg	4.1 Kg	6.1 Kg

(*) 10-32Vdc

For applications requiring compliance with EN 61131-2 and specifically in reference to 10 ms voltage dips (according to EN 61000-4-29), the lower power supply voltage limit is 20,4Vdc.



4 Technical Data

4.1 Dimensions

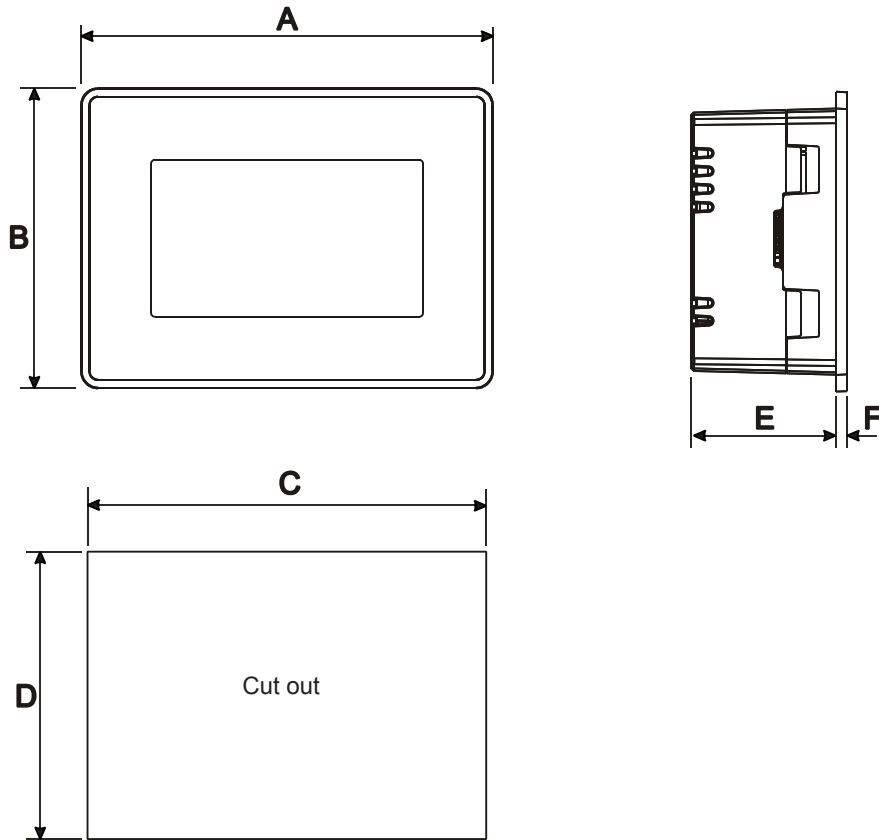

MODEL	A	B	C	D	E	F
eX705M	147mm/5.78"	107mm/4.21"	136mm/5.35"	96mm/3.78"	56mm/2.40"	8mm/0.31"



4 Technical Data

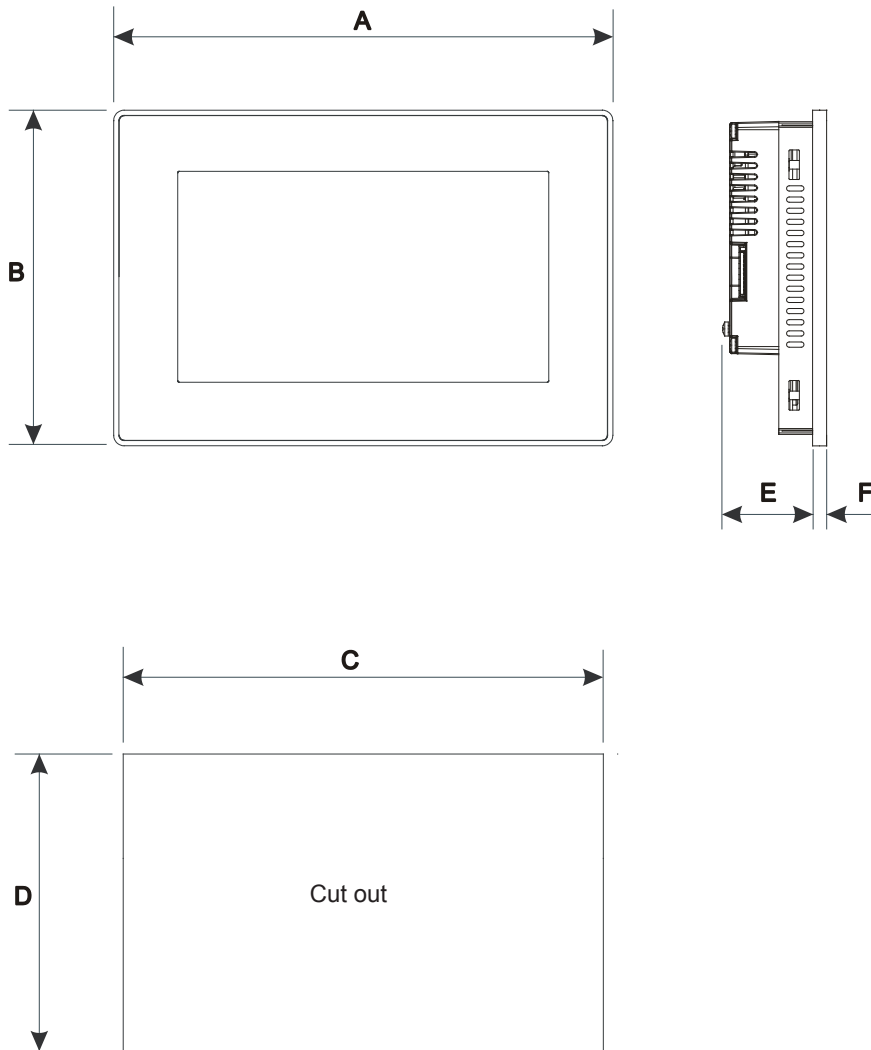

MODEL	A	B	C	D	E	F
eX707M	187mm/7.36"	147mm/5.79"	176mm/6.90"	136mm/5.35"	47mm/1.85"	8mm/0.31"
eX710M	282mm/11.10"	197mm/7.80"	271mm/10.67"	186mm/7.32"	56mm/2.20"	8mm/0.31"
eX712M	344,5mm/13.56"	163mm/6.41"	332,5mm/13,09"	163mm/6,41"	49mm/1,92"	8mm/0,31"
eX715M	422mm/16.60"	267mm/10.50"	411mm/16.18"	256mm/10.00"	56mm/2.20"	8mm/0.31"
eX721M	552mm/21.73"	347mm/13.66"	541mm/21.30"	336mm/13.22"	56mm/2.20"	8mm/0.31"



4 Technical Data

4.2 Installation Environment

Avoid prolonged exposition to direct sunlight to avoid the risk of overheating the device.

The equipment is not intended for installation in contact with corrosive chemical compounds. Check the resistance of the front panel to a specific compound before installation.

Do not use tools of any kind (screwdrivers, etc.) to operate the touch screen of the panel.

In order to meet the front panel protection classifications, proper installation procedure must be followed:

- the borders of the cutout must be flat
- screw up each fixing screw until the bezel corner get in contact with the panel.
- the cutout for the panel must be of the dimensions indicated in this manual.

The IP66 is guaranteed only if:

- max deviation from the plane surface to the cut-out: $\leq 0.5\text{mm}$
- thickness of the case where is mounted the equipment: from 1,5mm to 6mm
- max surface roughness where the gasket is applied: $\leq 120\text{ um}$

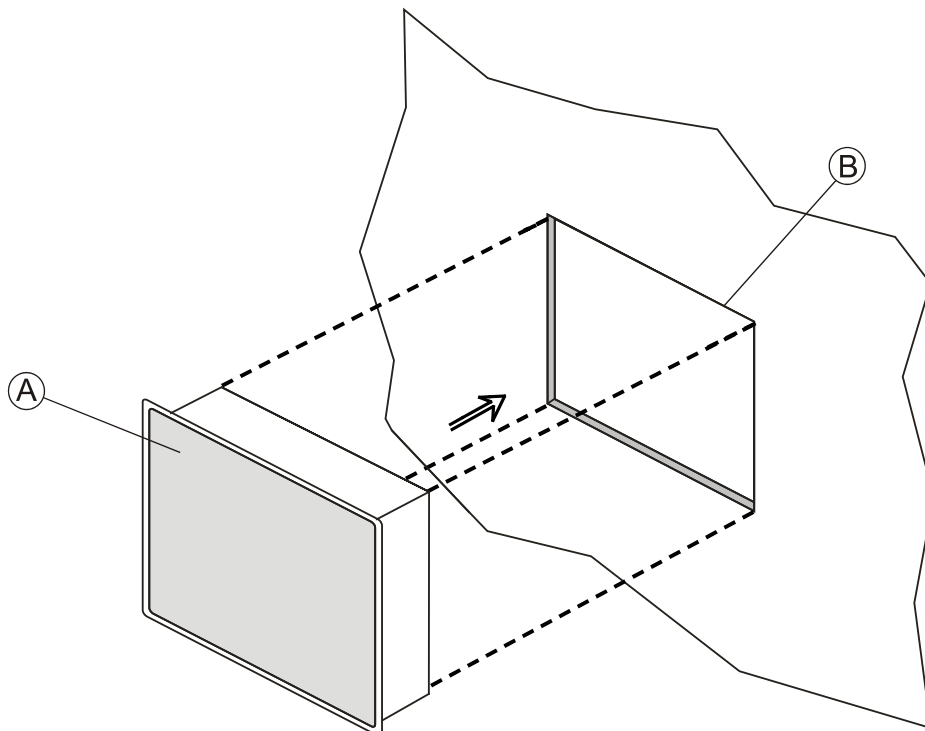

A. HMI
B. Installation cut-out



4 Technical Data

4.3 Safety instruction



For all installation notes, please refer to the Installation Guide provided with the product.

4.4 Installation Procedure

Place the fixing brackets contained in the fixing kit as shown in figure

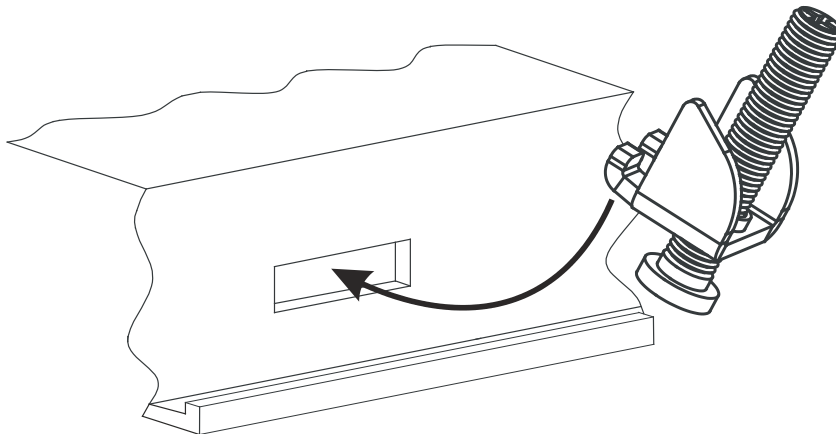

CAUTION

Tightening torque: 130Ncm or screw each fixing screw until the bezel corner gets in contact with the panel.



5 Connections

eX705M

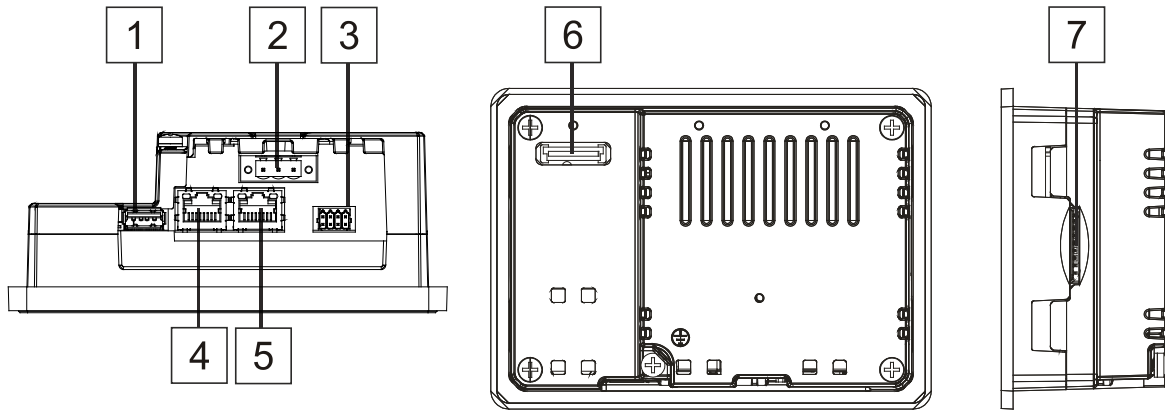

Fig. 5.1

1. USB Port V2.0, max. 500 mA - for maintenance only
2. Power Supply
3. Serial port
4. Ethernet Port 0 (10/100Mb)
5. Ethernet Port 1 (10/100Mb)
6. Expansion slot for Plugin module
7. SD Card Slot



5 Connections

eX707M, eX710M, eX712M, eX715M, eX721M

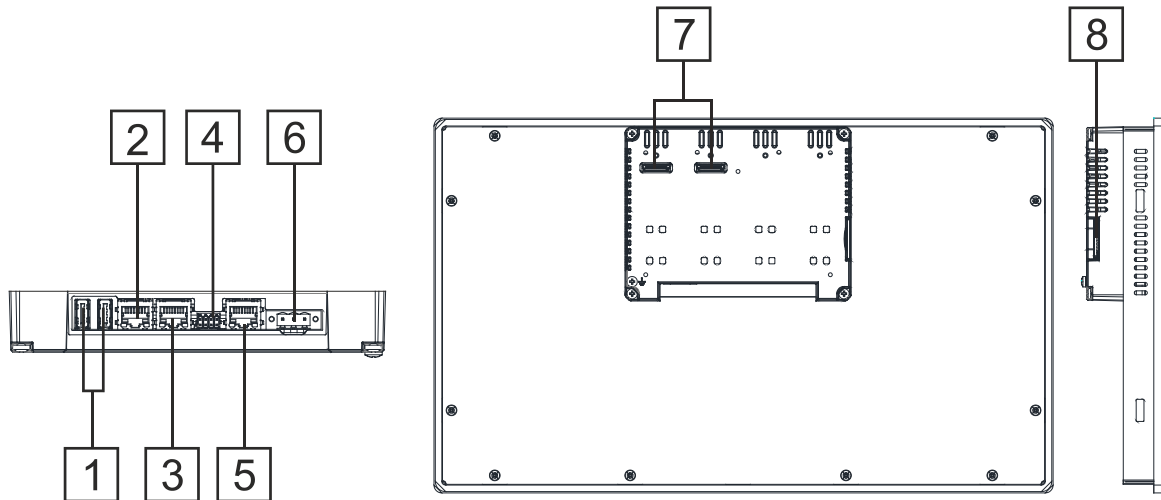

Fig. 5.2

1. USB Port V2.0, max. 500 mA - for maintenance only
2. Ethernet port 2 (10/100Mb)
3. Ethernet port 1 (10/100Mb)
4. Serial Port
5. Ethernet port 0 (10/100/1000Mb)
6. Power Supply
7. 2x Expansion slot for Plugin module
8. SD Card Slot



5 Connections

5.1 Serial Port

The serial port is used to communicate with the PLC or with another type of controller. Different electrical standards are available for the signals in the PLC port connector: RS-232, RS-422, RS-485.

The serial port is software programmable. Make sure you select the appropriate interface in the programming software.

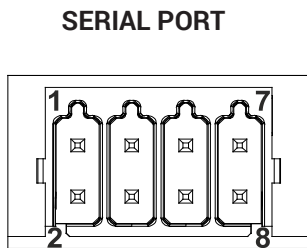

RS-232

Pin	Description
1	RX
2	TX
3	CTS
4	RTS
5	+5V output
6	GND
7	
8	SHIELD

RS-422, RS-485

Pin	Description
1	CHB-
2	CHA-
3	CHB+
4	CHA+
5	+5V output
6	GND
7	
8	SHIELD

To operate in RS-485 pins 1-2 and 3-4 must be connected externally.

The communication cable must be chosen for the type of device being connected.

5.2 Ethernet Port

The Ethernet port have two status indicators. Please see description in figure.

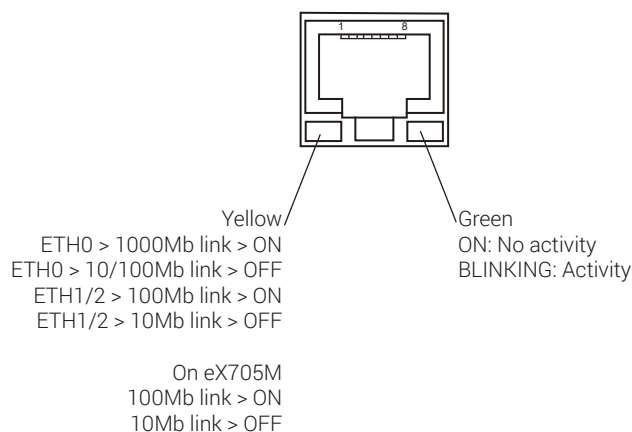



5 Connections

5.3 Optional plugin module

eX Series 700M panels have several optional plugin module, multiple modules configurations are possible.

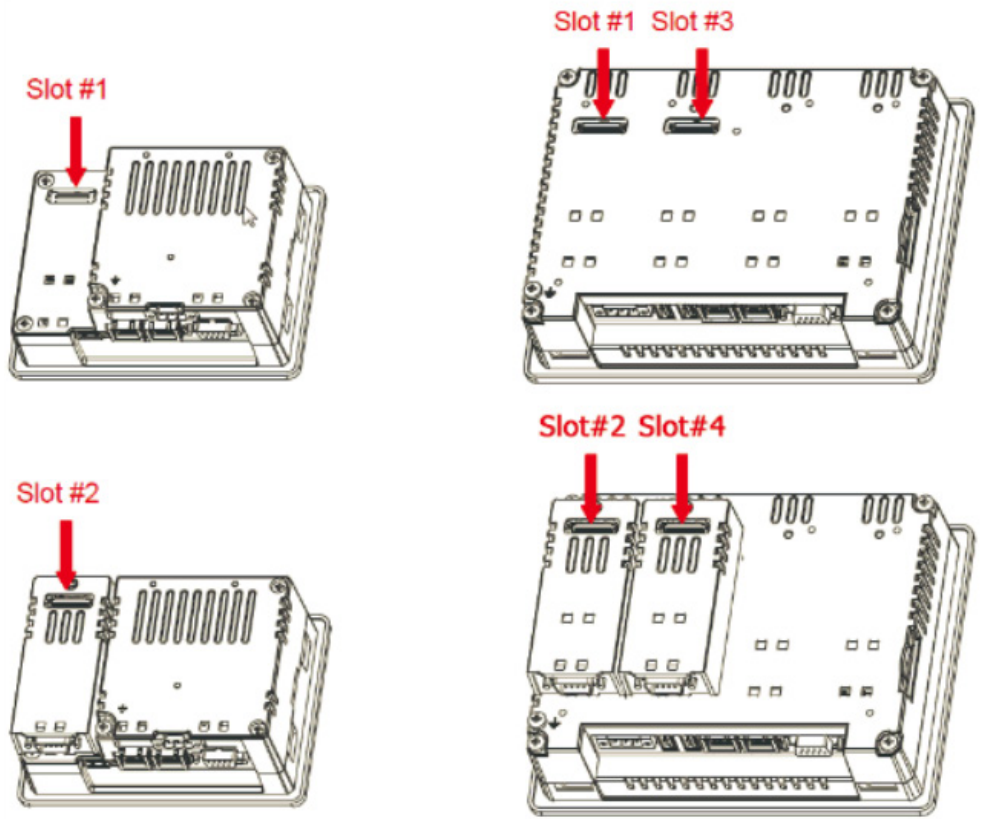

Slot#2 and Slot#4 are available only if plugin module has the “bus extension connector”.

Each slot carries three communication channels:

- 1 serial interface
- 1 CAN interface
- 1 SPI interface
- 1 2G/3G interface

Note: It is not possible to stack two modules that are using the same type of interface.



5 Connections

5.4 Optional plugin module identification

Note: the PLCM01 label is used as an example for PLCM01, PLCM09X, PLIO03

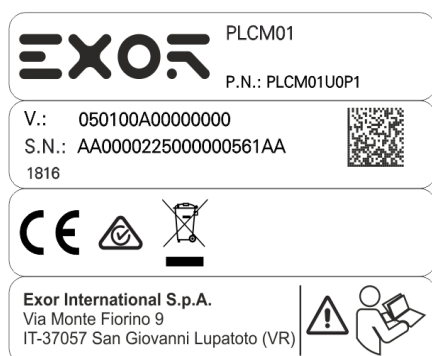

product model name	PLCM01
product part number	PLCM01U0P1
year/week of production	1816
serial number	AA0000225000000561AA
version id of the product	050100A000000000
manufacturer address	Exor International S.p.A. Via Monte Fiorino 9 IT-37057 San Giovanni Lupatoto (VR)



5 Connections

5.5 Optional plugin module installation procedure

PLCM

PLIO03

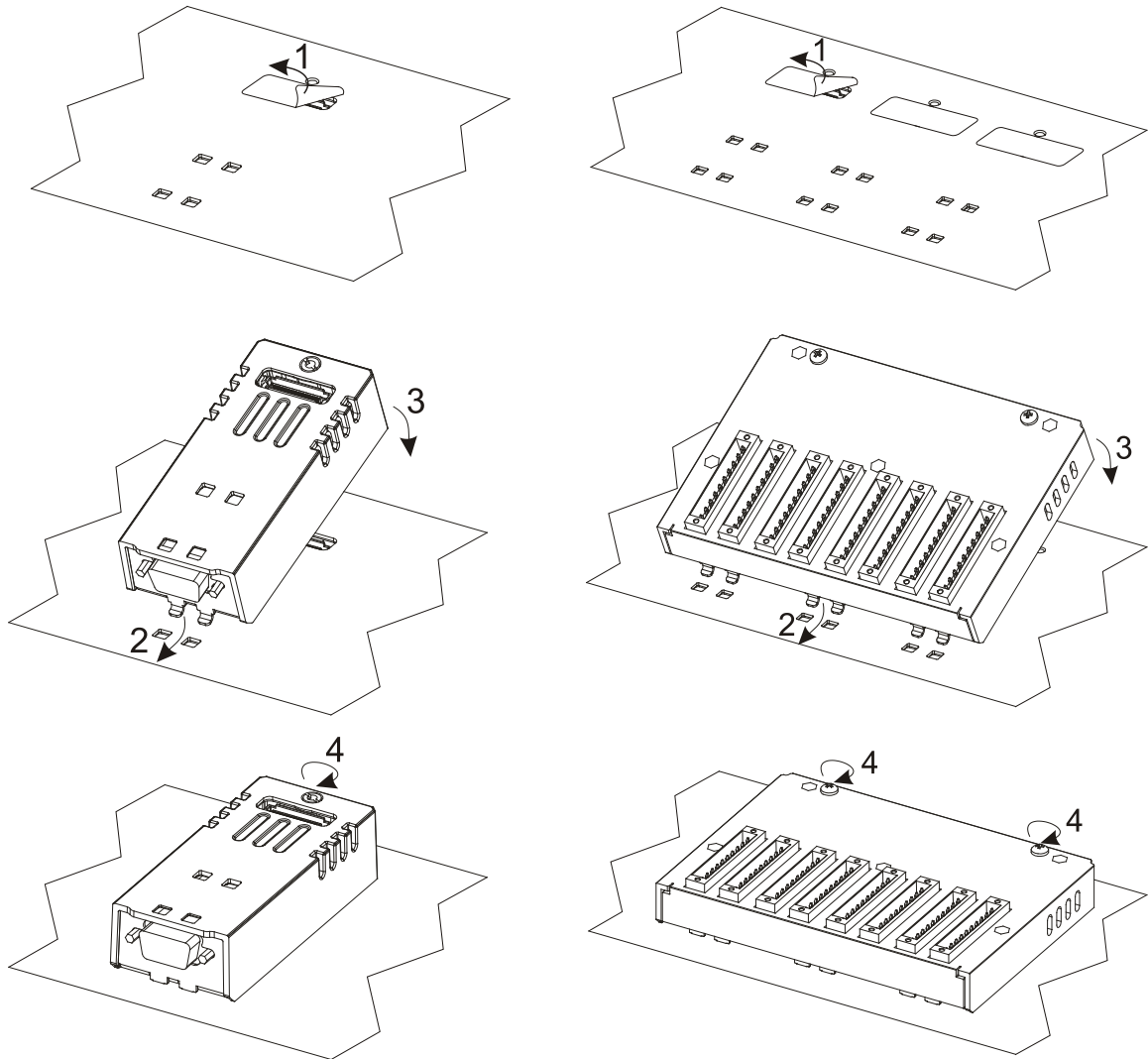



5 Connections

Below you can find relation between modules ATEX and IECEx certified and max number of modules that can be used into eX700M series panels, based on their Interface Type:

Module	Application	Max Modules	Interface Type	Bus Extension connector
PLCM01	CAN	1 for eX705M 2 for other panels	CAN	Y
PLCM01-NE	CAN	1 for eX705M 2 for other panels	CAN	N
PLCM09X	3G modem	1		Y
PLIO03	Multifunction I/O	1	SPI	N

PLCM01 / PLCM01-NE:

Operating temperature -20°C to 60°C

PLCM09X:

Operating temperature -20°C to 60°C

PLIO03:

with part number PLIO03xxxxY where:

- Y≤2 is operating temperature range $0^{\circ}\text{C} \leq T_{\text{amb}} \leq +50^{\circ}\text{C}$ with Operating Temperature Code T5 (vertical installation), 12-30VDC
- Y>2 is operating temperature range $-20^{\circ}\text{C} \leq T_{\text{amb}} \leq +60^{\circ}\text{C}$ with Operating Temperature Code T4 (vertical installation), 12-30VDC



Note the above different "Operating Temperature Code" for different part number of PLIO03 module.

PLCM and PLIO03 electrical ratings:

- PLCM01: For electrical rating refers to the host eX700 models.
- PLCM09X: 2xDigital Inputs voltage 12÷30 Vdc, 3mA; 2xDigital Outputs voltage 12÷30 Vdc, 0.5A
- PLIO03: 20xDigital Inputs voltage 12÷30 Vdc; 12xDigital Outputs voltage 12÷30 Vdc, 0.5A; 4xAnalog inputs 0÷10 Vdc, 4-20mA; 4xAnalog outputs: 0÷10 Vdc, 4-20mA



5 Connections

Below you can find relation between modules and max number of modules that can be used into eX series 700M panels, based on their Interface Type:

Module	Application	Max Modules	Interface Type	Bus Extension connector
PLCM02	KNX	1	Serial	N
PLCM03	Serial RS232	2	Serial	Y
PLCM04	Serial RS485	2	Serial	Y
PLCM06	Profibus DP	1	SPI	N
PLCM10	4G wireless modem	1		Y
PLIO04	Multifunction I/O	1	SPI	N
PLIO06	Compact I/O	2	SPI	N
PLIO07	Compact I/O	2	SPI	N

Max modules refers to max number of modules can be plugged into the HMI (all slots).

If you are planning to use PLCM03 and PLCM04 (additional serial ports) you will obtain following "COM - Slot#" association:

- a module plugged in Slot#1 or into Slot#2 will be COM2,
- a module plugged in Slot#3 or into Slot#4 will be COM3.

If you are planning to use two PLCM01 (CAN interface) you will obtain following Slot# association:

- a module plugged in Slot#1 or into Slot#2 will be the CanPort 0,
- a module plugged in Slot#3 or into Slot#4 will be the CanPort 1.



6 Power Supply, Grounding and Shielding

The power supply terminal block is shown in the figure below.

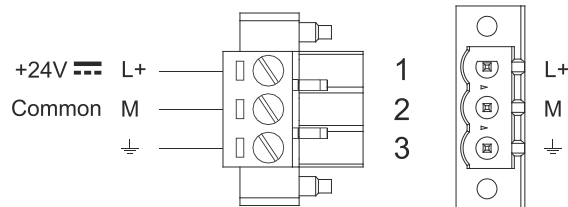

Fig. 6.1

3 conductor 1,5mmq wire size minimum, minimum temperature conductor rating 105°C.

Note: Ensure that the power supply has enough power capacity for the operation of the equipment.

The unit must always be grounded to earth with 1,5mmq wire size minimum. Grounding helps limit the effects of noise due to electromagnetic interference on the control system.

Earth connection will have to be done using either the screw or the faston terminal located near the power supply terminal block. A label helps identify the ground connection. Also connect to ground the terminal 3 on the power supply terminal block.

The power supply circuit may be floating or grounded. In the latter case, connect to ground the power source common as shown in figure (see below) with a dashed line.

When using the floating power scheme, note that the panes internally connects the power common to ground with a 1MΩ resistor in parallel with a 4,7nF capacitor.

The power supply must have double or reinforced insulation.

The suggested wiring for the power supply is shown below.

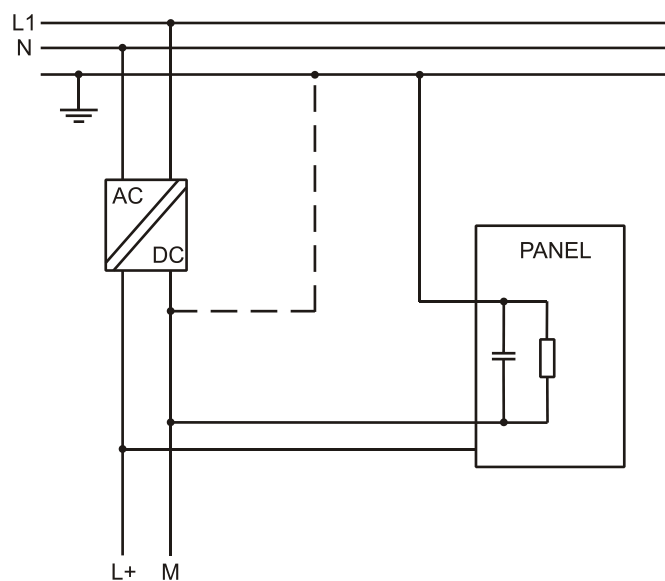

Fig. 6.2

All the electronic devices in the control system must be properly grounded. Grounding must be performed according to applicable regulations.



7 Battery

These devices are equipped with rechargeable Lithium battery, not user-replaceable.
The following information is maintained by the battery:

- hardware real-time clock (date and time)

Charge:

At first installation must be charged for 48 hours.

When the battery is fully charged, it ensures a period of 3 months of data back-up at 25°C.

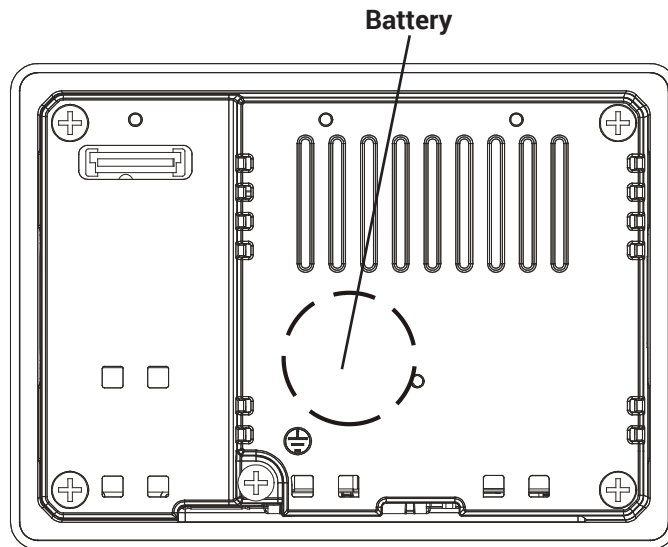

Fig. 7.1: eX705M

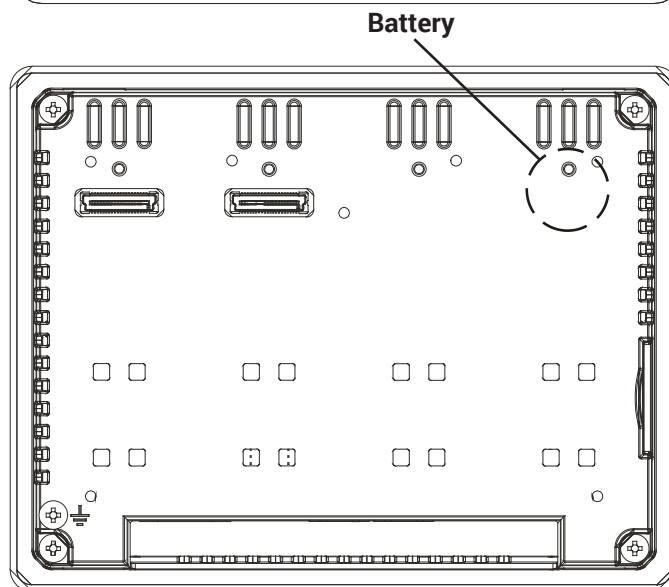

Fig. 7.2: eX707M, eX710M, eX712M, eX715M, eX721M



ATTENTION

Dispose of batteries according to local regulations.



ATTENTION

This device cannot be disposed of as a domestic waste but according to WEEE European Directive 2012/19/EU





8 Special Instruction for Use

- The equipment shall only be used in an area of not more than pollution degree 2, as defined in IEC/EN 60664-1.
- The equipment shall be installed in an enclosure that provides a degree of protection not less than IP 54 in accordance with IEC/EN 60079-15.
- Transient protection shall be provided that is set at a level not exceeding 140 % of the peak rated voltage value at the supply terminals to the equipment.
- Install the HMI device according to the accompanying installation instructions.
- Ground the HMI device according to the accompanying installation instructions.
- Only qualified personnel may install the HMI device or repair it.
- Ensure that the ventilation holes are not covered.
- Care shall be taken not to allow layers of dust to form on the graphic panel in a way that might cause the accumulation of static charges. Keep the faceplate of the HMI device clean: the equipment must be cleaned only with a soft cloth and neutral soap product. Do not use solvents.
- This device should not be used for purposes and methods other than indicated in this document and in the documentation accompanying the product.

9 Getting Started

eX Series 700M HMI products delivery configuration is based on a loader. Use the services of the loader to install applications on the device such as JMobile runtime or browsers.

JMobile Studio version V4.5 or higher is required. JMobile Studio is a software tool that must be properly installed on a computer running Microsoft Windows.

There are two options to transfer a JMobile application project to a HMI device:

- | | |
|----------|---|
| Ethernet | Connect the HMI device to the computer with an Ethernet network. In JMobile Studio select the command Run/Download to target. You may have to ensure that the proper firewall policy has been configured in the computer to allow JMobile Studio to access the network. |
| USB | Create an Update Package using JMobile Studio and copy it to a USB Flash drive. |

Updated product documentation is available at www.exorint.com.

For the products described in this manual please check:

- Systems Settings User Manual
- JMobile Studio User Manual
- Web Browser User Manual



10 Unpacking and Packing Instructions

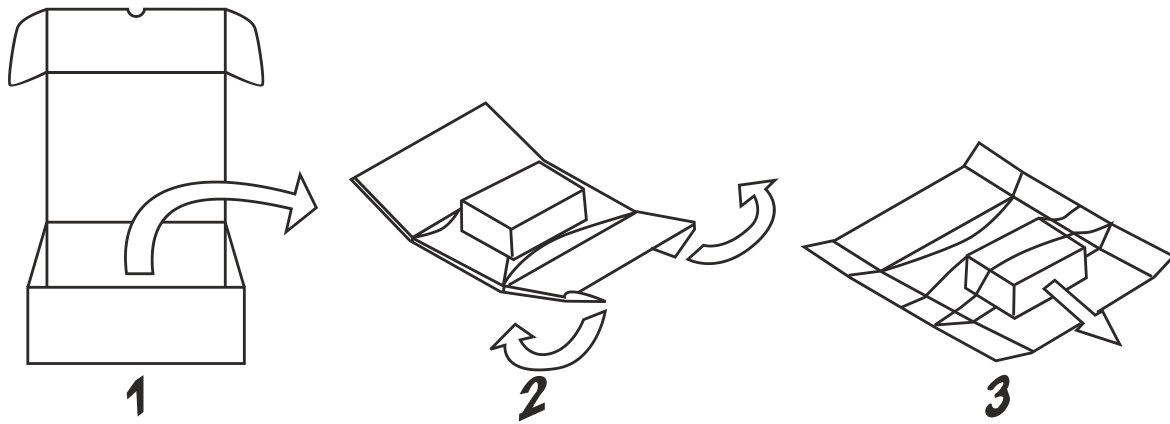

Fig. 10.1: eX705M, eX707M, eX710M, eX712M

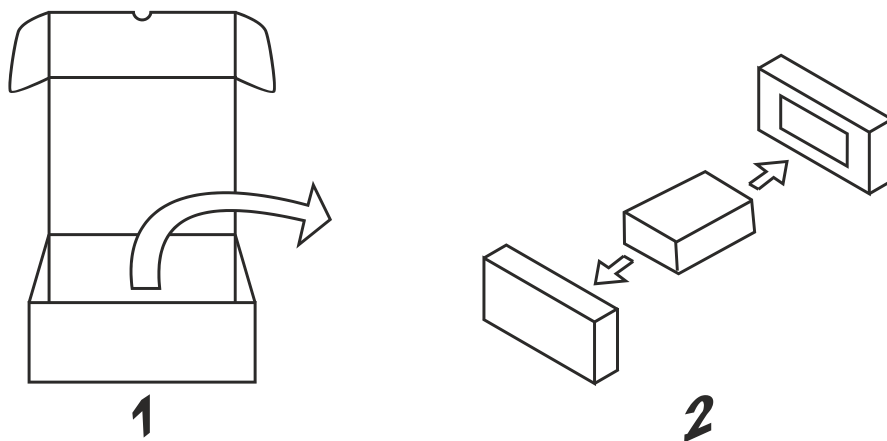

Fig. 10.2: eX715M, eX721M

To repack the unit, please follow the instructions backwards.



SCATTERGOOD & JOHNSON LTD

ELECTRICAL ENGINEERING & FLUID CONTROL DISTRIBUTORS

Est.1899

At Scattergood & Johnson Ltd, we pride ourselves on being a technical distributor to specialist industries.

Working with a range of quality product manufacturers across a number of specialist markets, we are not your average 'box shifter' - we are your technical and supply chain partner.

We fully support every product we sell - for free! Our internal team and external sales engineers can answer any product or application question, no matter the complexity.

Backing up this technical ability is a range of 50,000+ products available from stock for nationwide next day delivery (same day if required!), or you can collect what you need from any of our trade counters around the UK.

Select your specialist interest below to learn more about how we can help.

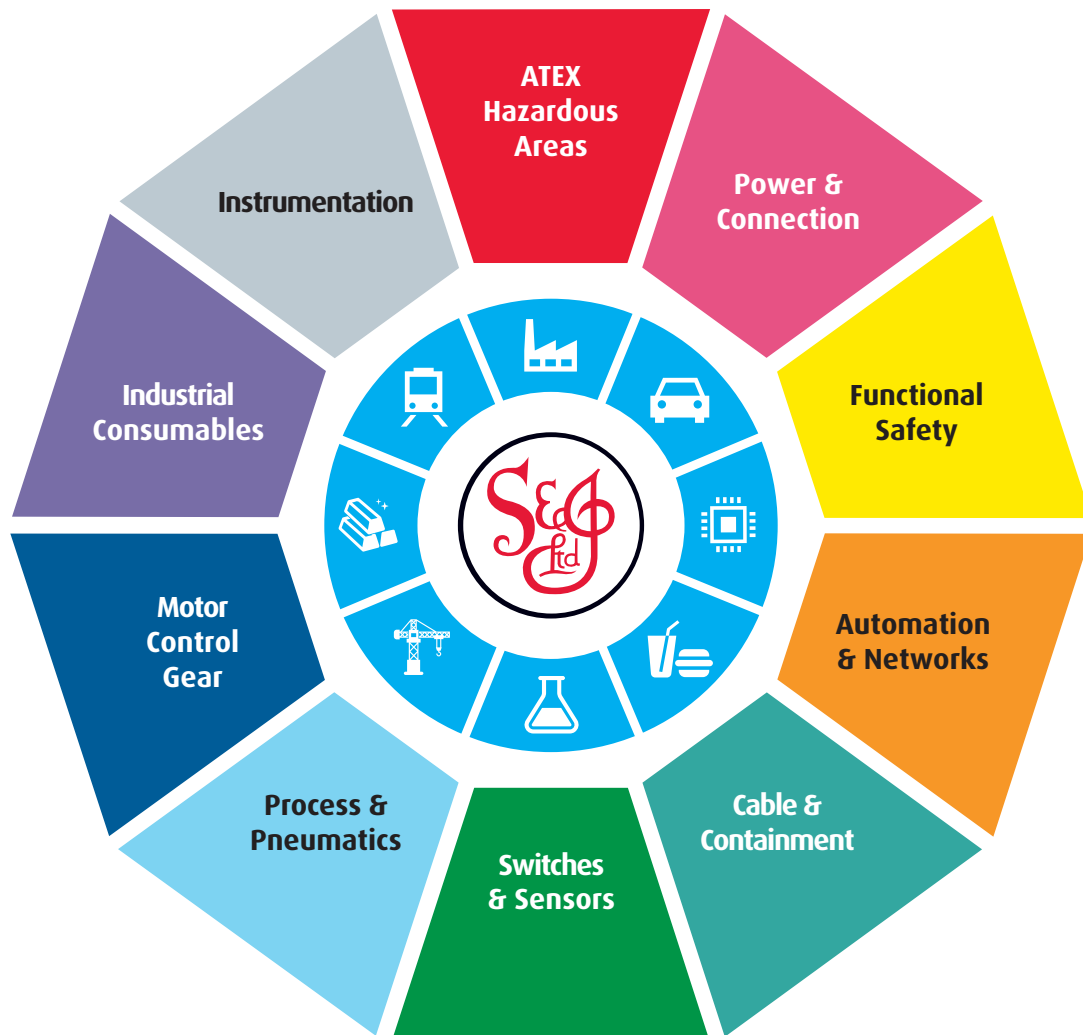

Online, In Branch and On the Road - Scattergood & Johnson Ltd, there when you need us.

www.scatts.co.uk