

Capacitive Sensors Series 80 - PNP

Housing M 8 x 1

- Housing material: PEEK (FDA 21 CFR 177.2415)
- Level control

With manufacturer certificate

for use in zone 22

Ex II 3D Ex mc IIIC T101°C Dc IP67 X



| | |
|---|------------------------------------|
| Technical data | Non-flush mountable |
| Level sensor, in contact with the product | Medium dependent |
| Electrical version | 3 wire DC |
| Output function | Normally open |
| Type PNP | KAS-80-A21/61-S-K-PEEK-3D |
| Art.-No. | KA 1420 |
| Operating voltage (U _B) | 10...35 V DC |
| Voltage drop max. (U _D) | ≤ 2.0 V |
| Permitted residual ripple max. | 10 % |
| Operating current (I _e) | 0...150 mA |
| No-load current (I _o) | Typ. 15 mA |
| Frequency of operating cycles max. | 50 Hz |
| Permitted ambient temperature | -25...+70 °C |
| LED-display | Yellow |
| Protective circuit | Built-in |
| Degree of protection IEC 60529 | IP 67* |
| Norm | EN 60947-5-2 |
| Connection cable | 2 m, PUR, 3 x 0.14 mm ² |
| Housing material | PEEK (FDA 21 CFR 177.2415) |
| Active surface | PEEK (FDA 21 CFR 177.2415) |
| Lid | PA / PPO |
| Media optimized | Yes |

* With sealed potentiometer screw

All specifications are subject to change without notice. (01.04.2016)

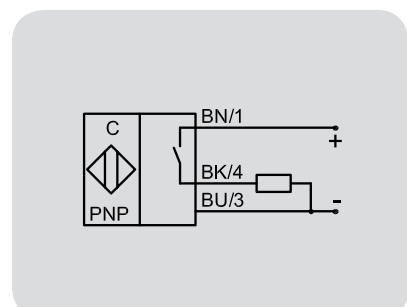
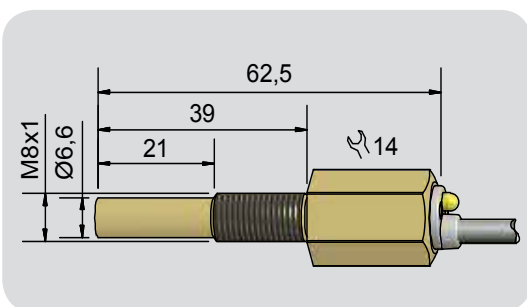



SCATTERGOOD & JOHNSON LTD

ELECTRICAL ENGINEERING & FLUID CONTROL DISTRIBUTORS

Est.1899

At Scattergood & Johnson Ltd, we pride ourselves on being a technical distributor to specialist industries.

Working with a range of quality product manufacturers across a number of specialist markets, we are not your average 'box shifter' - we are your technical and supply chain partner.

We fully support every product we sell - for free! Our internal team and external sales engineers can answer any product or application question, no matter the complexity.

Backing up this technical ability is a range of 50,000+ products available from stock for nationwide next day delivery (same day if required!), or you can collect what you need from any of our trade counters around the UK.

Select your specialist interest below to learn more about how we can help.



Online, In Branch and On the Road - Scattergood & Johnson Ltd, there when you need us.

www.scatts.co.uk