

Data Sheet | Item Number: 750-8000
Basic Controller 100; 2 x ETHERNET; ECO

<https://www.wago.com/750-8000>

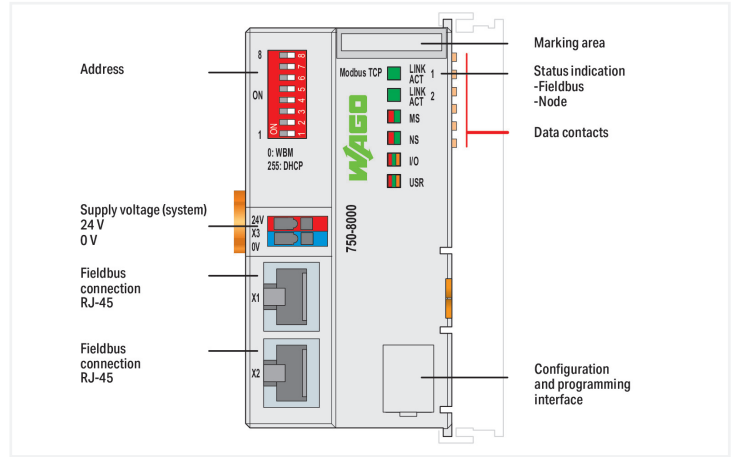
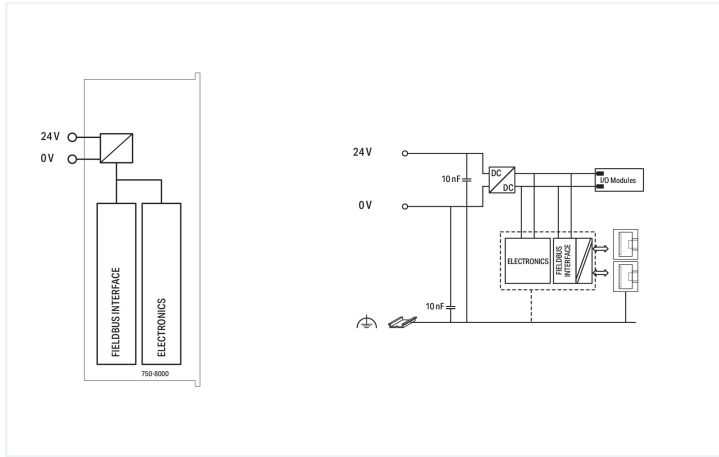

This controller can be used as a programmable controller within Ethernet networks along with the WAGO I/O System. The controller detects all connected I/O modules and creates a local process image. This process image may include a mixed arrangement of analog (word-by-word data transfer) and digital (bit-by-bit data transfer) modules. Two ETHERNET interfaces and an integrated switch allow the fieldbus to be wired in a line topology, eliminating additional network devices, such as switches or hubs. Both interfaces support autonegotiation and Auto-MDI(X). The DIP switch configures the last byte of the IP address and may be used for IP address assignment. The controller is designed for fieldbus communication in Modbus® networks. It also supports a wide variety of standard ETHERNET protocols (e.g., HTTP(S), BootP, DHCP, DNS, SNTP, SFTP, SNMP). An integrated Webserver provides user configuration options, while displaying PLC status information. The controller has a role-based user management and supports Syslog according to RFC 5424. The IEC 61131-3 programmable controller is multitasking-capable.

Technical data	
Communication	Modbus (TCP, UDP)
ETHERNET protocols	HTTP(S) BootP DHCP DNS SNTP SFTP SNMP (V2 & V3) TLS1.3 Syslog
Visualization	Web server with integrated RBAC (Role Based Access Control)
CPU	32 bits
Programming languages per IEC 61131-3	Instruction List (IL) Ladder Diagram (LD) Function Block Diagram (FBD) Continuous Function Chart (CFC) Structured Text (ST) Sequential Function Chart (SFC)
Programming environment	CODESYS V3.5
Configuration options	WAGO-I/O-CHECK Web-Based Management CODESYS Library
Baud rate (communication/fieldbus 1)	10/100 Mbit/s
Baud rate	10/100 Mbit/s
Transmission medium (communication/fieldbus)	Twisted pair S-UTP; 100 Ω; Cat. 5; 100 m maximum cable length
Transmission performance	Class D per EN 50173
Program memory	16 MB
Data memory	16 MB
Non-volatile software memory	64 KB
Number of modules per node (max.)	250
Number of modules without a bus extension (max.)	64
Input and output process image (fieldbus) max.	1020 words/1020 words

Technical data

Indicators	LED (LINK/ACT) green: Network connection via ports 1 ... 2; LED (MS, NS) red/green: Status of node, network; LED (I/O, USR) red/green/orange: Local data bus status, status programmable by user
Supply voltage (system)	24 VDC (-25 ... +30 %); via pluggable connector
Input current (typ.) at nominal load (24 V)	300 mA
Power supply efficiency (typ.) at nominal load (24 V)	90 %
Current consumption (5 V system supply)	390 mA
Total current (system supply)	700 mA
Isolation	500 VAC system/field

Connection data

Connection technology: communication/fieldbus	Modbus (TCP, UDP): 2 x RJ-45
Connection technology: system supply	2 x CAGE CLAMP®
Connection type 1	System supply
Solid conductor	0.08 ... 2.5 mm ² / 28 ... 14 AWG
Fine-stranded conductor	0.08 ... 2.5 mm ² / 28 ... 14 AWG
Strip length	8 ... 9 mm / 0.31 ... 0.35 inches
Connection technology: device configuration	1 x Male connector; 4-pole

Physical data

Width	49.5 mm / 1.949 inches
Height	96.8 mm / 3.811 inches
Depth	71.9 mm / 2.831 inches
Depth from upper-edge of DIN-rail	64.7 mm / 2.547 inches

Mechanical data

Weight	111.5 g
Color	light gray
Housing material	Polycarbonate; polyamide 6.6
Conformity marking	CE

Environmental requirements

Ambient temperature (operation)	0 ... +55 °C
Ambient temperature (storage)	-25 ... +85 °C
Protection type	IP20
Pollution degree	2 per IEC 61131-2
Operating altitude	without temperature derating: 0 ... 2000 m; with temperature derating: 2000 ... 5000 m (0.5 K/100 m); 5000 m (max.)
Relative humidity (without condensation)	95 %
Mounting position	any
Mounting type	DIN-35 rail
Vibration resistance	4g per IEC 60068-2-6
Shock resistance	15g per IEC 60068-2-27
EMC immunity to interference	per EN 61000-6-2, marine applications
EMC emission of interference	per EN 61000-6-3, marine applications
Exposure to pollutants	per IEC 60068-2-42 and IEC 60068-2-43
Fire load	1.407 MJ
Permissible H ₂ S contaminant concentration at a relative humidity 75 %	10 ppm
Permissible SO ₂ contaminant concentration at a relative humidity 75 %	25 ppm



Environmental Product Compliance

RoHS Compliance Status	Compliant, No Exemption
------------------------	-------------------------

Approvals / Certificates

Declarations of conformity and manufacturer's declarations

Approval	Standard	Certificate Name
EU-Declaration of Conformity WAGO GmbH & Co. KG	-	-
UK-Declaration of Conformity WAGO GmbH & Co. KG	-	-

Approvals for marine applications



Approval	Standard	Certificate Name
DNV DNV GL SE	DNV-CG-0339, Aug. 2021	TAA0000194

Approvals for hazardous areas



Approval	Standard	Certificate Name
UL Underwriters Laboratories Inc. (HAZARDOUS LOCATIONS)	-	E198726

Subject to changes. Please also observe the further product documentation!

Current addresses can be found at: www.wago.com



**SCATTERGOOD
& JOHNSON LTD**
ELECTRICAL ENGINEERING & FLUID CONTROL DISTRIBUTORS

Est.1899

At Scattergood & Johnson Ltd, we pride ourselves on being a technical distributor to specialist industries.

Working with a range of quality product manufacturers across a number of specialist markets, we are not your average 'box shifter' - we are your technical and supply chain partner.

We fully support every product we sell - for free! Our internal team and external sales engineers can answer any product or application question, no matter the complexity.

Backing up this technical ability is a range of 50,000+ products available from stock for nationwide next day delivery (same day if required!), or you can collect what you need from any of our trade counters around the UK.

Select your specialist interest below to learn more about how we can help.



Online, In Branch and On the Road - Scattergood & Johnson Ltd, there when you need us.

www.scatts.co.uk