



NEO X

Ex db eb Bulkhead

The latest Zone 1 LED X Series luminaire, the NEO X bulkhead focuses on the needs of the user by combining multiple lumen outputs with long term maintenance benefits. Providing a market leading range of photometric outputs using our X-series optics to efficiently illuminate any Zone 1/21 application, the NEO X is a true successor to the NexLED and Nevis ranges of bulkhead luminaires.

With a certified temperature range from -55°C up to +55°C the NEO X is the bulkhead for every environment and application. The optional benefit of a hot swap battery with excellent IP allows the maintainable components to be easily accessible, and ensures that the ground breaking NEO X is suitable for global use in any harsh or hazardous environment.



MADE IN
BRITAIN



International Approvals

Mounting Options

Bulkhead, Handrail

Standard Specification

NEO X Ex db eb LED Bulkhead

Type of Protection	Ex db eb (Flameproof, Increased Safety) Ex tb (Dust Protected Enclosure)
ATEX Classification	Group II Category 2 GD
Area Classification	Zone 1 and 21 areas to EN 60079-10-1 and EN 60079-10-2 with installation to EN 60079-14
Certificate	EU Type Examination Certificate CML22ATEX1473X IECEx Certificate of Conformity IECEx CML 22.0070X UK Type Examination Certificate CML 22UKEX1474X
Coding	Ex db eb IIB+H2 T* Gb Ex tb IIIC T76°C Db IP6X - Refer to table for T rating and Ambient
Enclosure	LM6 Marine grade aluminium body with UV resistant Polycarbonate diffuser
Entry	4 x M20 cable entries (c/w 3x plastic Ex plugs & 1x travel plug)
Termination	3 core 4mm ² max conductor with looping, Emergency 4 core 4mm ² max conductor with looping
Installation	4 x M6 Mounting holes (supplied with flush mount brackets)
Control Gear	Electronic Driver
Optical Distribution	Wide beam
Colour Temperature (CCT)	5000K (Cool White) Other temperature and colour options are available.
Colour Rendering Index (Ra)	>80
Maintenance	Front access to gearbox lid with 4x M5 retained screws
LED Lifetime @ 55°C Ambient	L70 > 200,000hrs
System Life @ Ambient	120,000hrs @ 25°C. (100,000hrs for EM & EMI)
Emergency Duration	3 Hour Duration (01L - 32% output, 02L - 21% Output)
Impact Protection	IK10
Ingress Protection	IP66/67 to EN 60529
Surge Protection	6kV
Electrical Supply	110-277V AC, 50/60Hz. 127-250V DC 220-240V AC for EM

Features

- ◆ Highly **Energy Efficient** >120lm/W up to 135lm/W (Non-Emergency) ◆ **Exit sign** options
- ◆ Available with **asymmetric walkway optic**, minimising light pollution ◆ **Small footprint** for areas of restricted space
- ◆ **Optional hot swap battery** for more efficient maintenance ◆ **Lumen options** from 1500-4300
- ◆ **120,000** maintenance free hours at 25°C (100,000hrs for EM and EMI)

Std. Cat No.	Delivered Output	Power Consumption	Tclass	T°C (Dust)	Ambient °C	Weight
NOXB/01L/LE	1550 lm	11.5W	T6	T76	-55 to +55	6kg
NOXB/02L/LE	2311 lm	17.5W	T6	T76	-55 to +55	6kg
NOXB/04L/LE	4363 lm	35W	T5	T76	-55 to +55	6kg
NOXB/01L/LE/EMI	1550 lm	15W	T5	T76	-25 to +55	7.0kg
NOXB/02L/LE/EMI	2311 lm	20.5W	T5	T76	-25 to +55	7.0kg

Options - Suffix to Catalogue No.

/M25	M25 Cable Entries
/BP	Nickel plated brass plugs (x3)
/M	Medium Beam Distribution (≈5% reduction in output)
/ASL	Asymmetric Beam along Length - Walkway Distribution (≈11% reduction in output)
/DM	DALI Dimmable driver (04L Non-Emergency Version only)
/P	Enclosure Epoxy Powder Painted (RAL 9005)
/EM	Hot Swap Battery (Only available with 01L & 02L versions)
/BNI	Battery Not Included (Not available with /EMI versions)
/3K	3000K (Warm White) LEDs *
/4K	4000K (Neutral White) LEDs *
/SC	6mm ² max Conductor Looping
/EL	Extra live termination facility (to match emergency circuit)

* may be subject to minimum order quantity

Accessories *order separately*

Order Code

Exit, left, right, up, down, sign kit	SNOXB1-0001
Hot Swappable Battery Assembly (not suitable for /EMI versions)	SNOXB1-0002

Standard Version

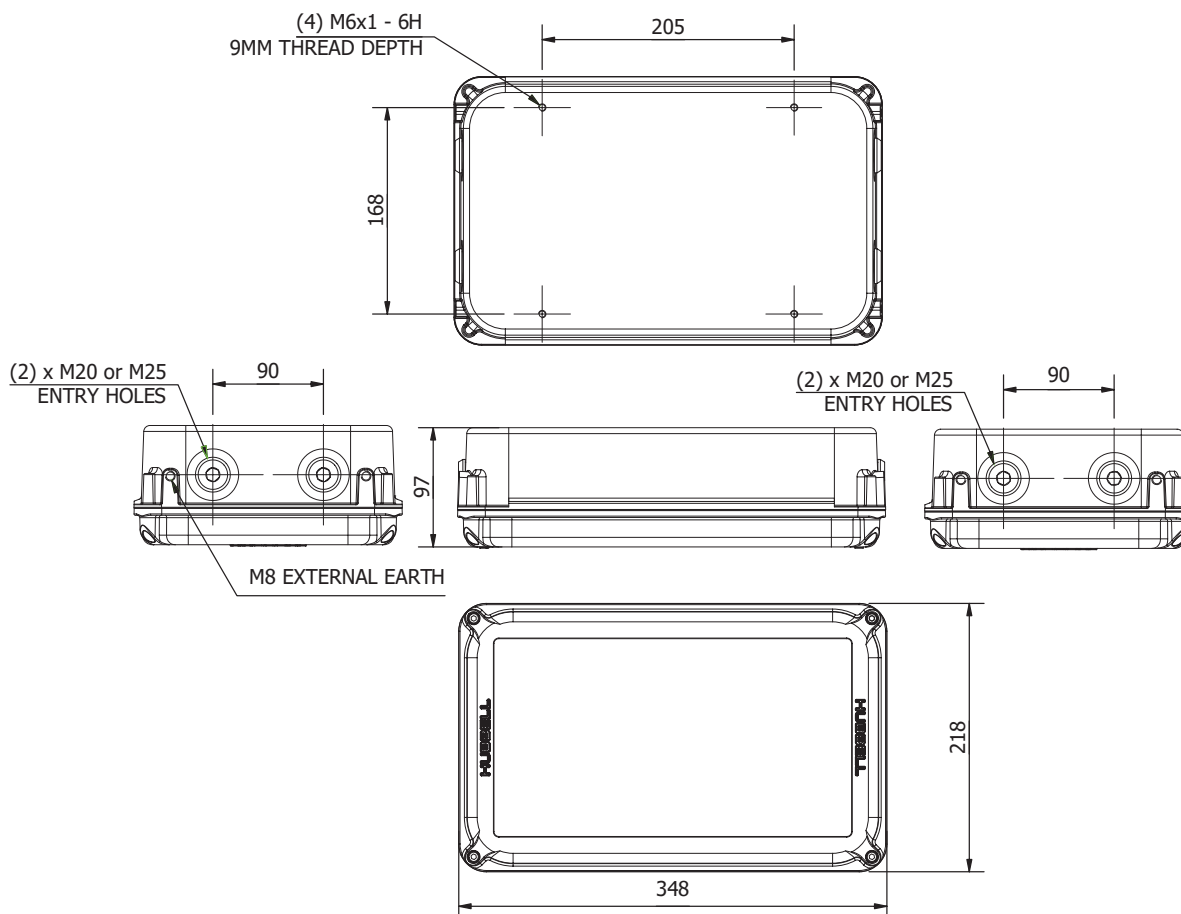

Product design and specifications are subject to change without notice. Please check the Chalmite website for latest specifications.

www.chalmit.com

Emergency Version

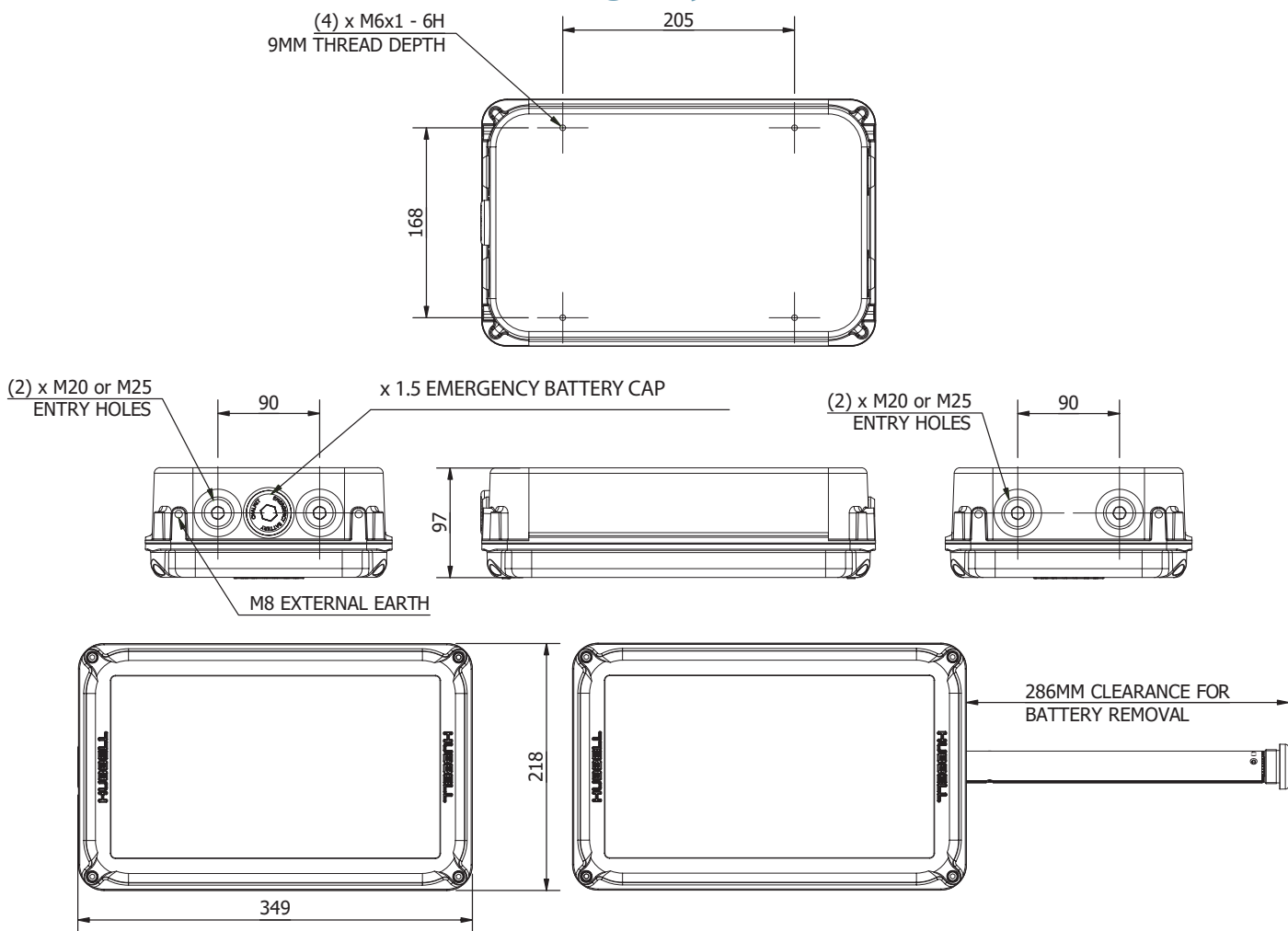

Wall Mount Bracket

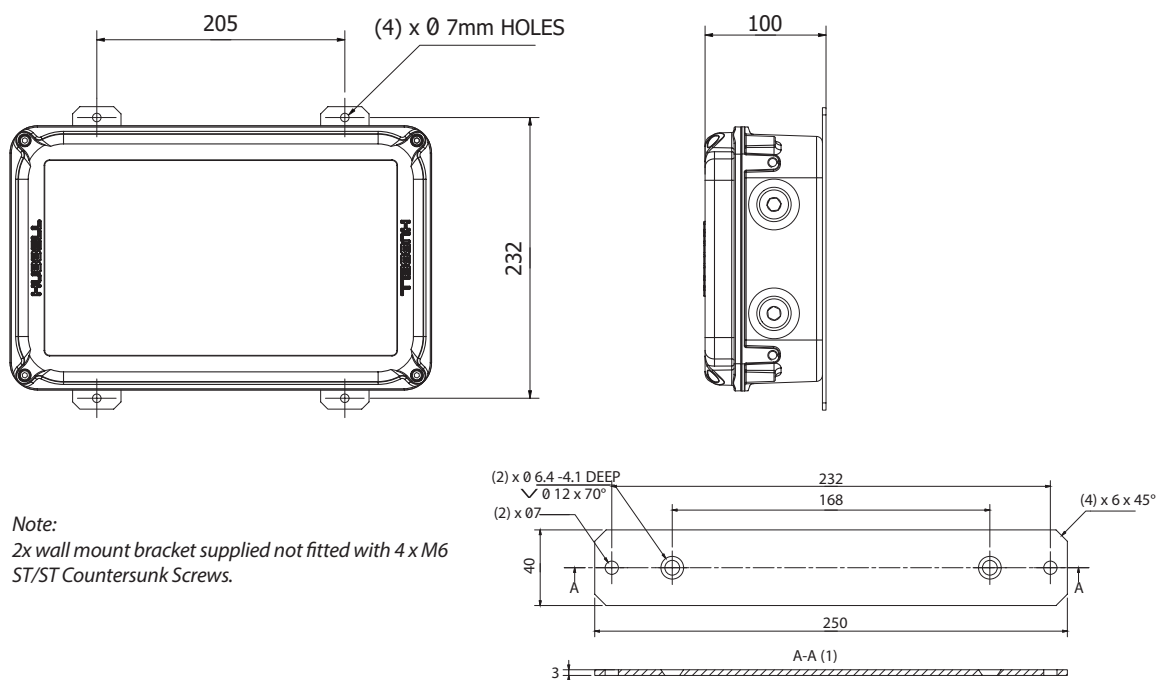



SCATTERGOOD & JOHNSON LTD

ELECTRICAL ENGINEERING & FLUID CONTROL DISTRIBUTORS

Est.1899

At Scattergood & Johnson Ltd, we pride ourselves on being a technical distributor to specialist industries.

Working with a range of quality product manufacturers across a number of specialist markets, we are not your average 'box shifter' - we are your technical and supply chain partner.

We fully support every product we sell - for free! Our internal team and external sales engineers can answer any product or application question, no matter the complexity.

Backing up this technical ability is a range of 50,000+ products available from stock for nationwide next day delivery (same day if required!), or you can collect what you need from any of our trade counters around the UK.

Select your specialist interest below to learn more about how we can help.



Online, In Branch and On the Road - Scattergood & Johnson Ltd, there when you need us.

www.scatts.co.uk