



# NeoX LED Linear Luminaire

## ATEX, IECEx and UKEX

### INSTALLATION, OPERATION AND MAINTENANCE INSTRUCTIONS

**Important:** Please read these instructions carefully before installing or maintaining this equipment. Good electrical practices should always be followed, and this data should be used as a guide only.

Fig. 1

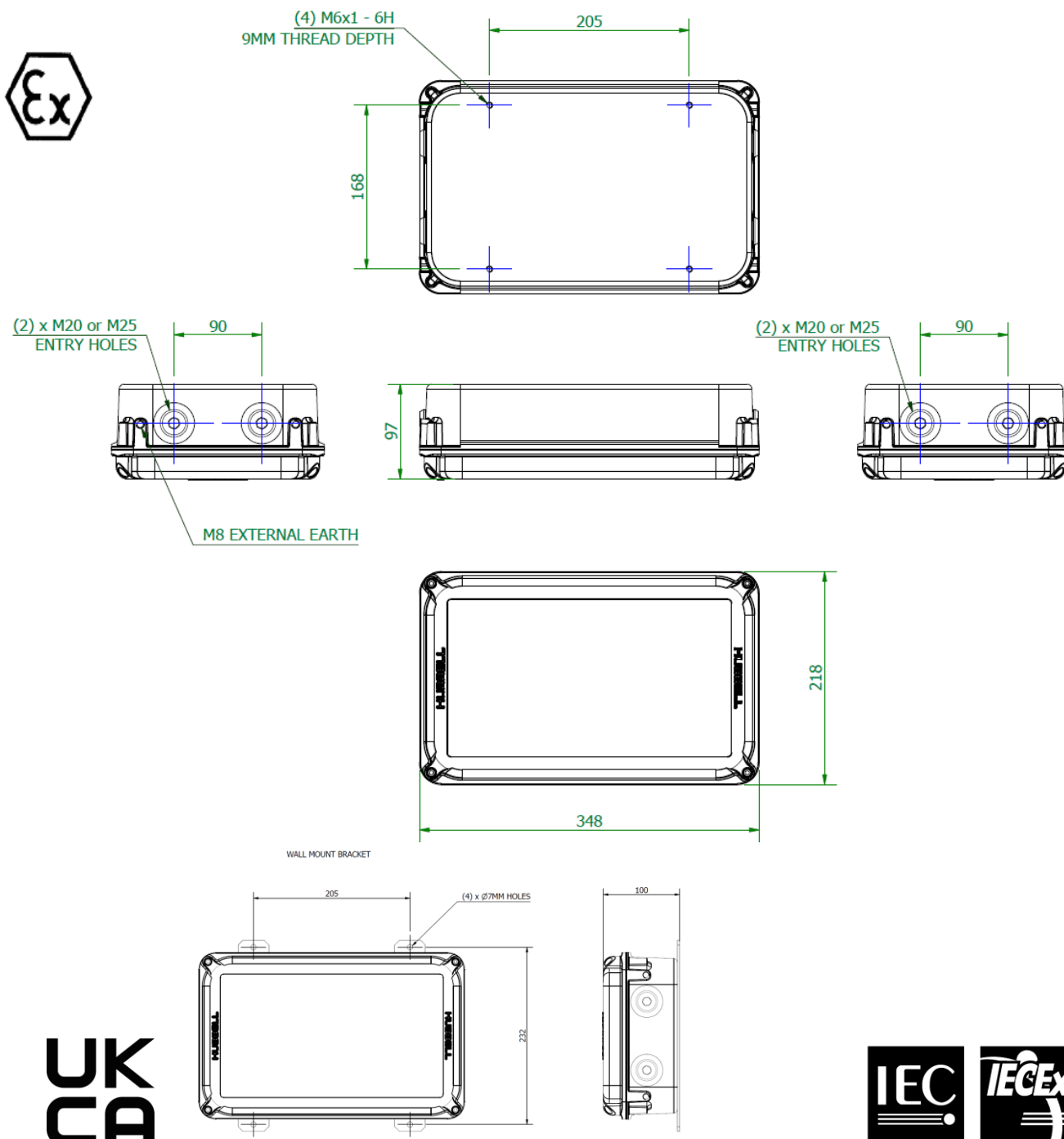



**IOM – NeoX - ZONE 1 LED (ATEX, IECEx and UKEX)**

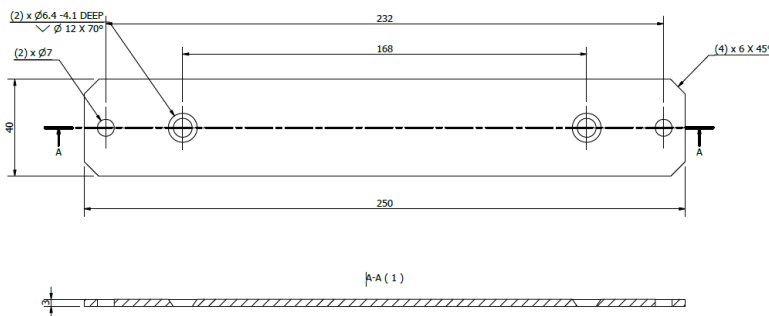



Wall mount strap as above provided not fitted with 4 x M6 ST/ST countersunk screws

**Specification**

Type of Protection	Ex d Driver, LED Engine (flameproof and increased safety), Ex eb Housing (Increased safety), Ex tb Housing (Dust)
Protection Standards	EN/IEC 60079-0, EN/IEC 60079-1, EN/IEC 60079-7, EN/IEC 60079-18, EN/IEC 60079-31.
Area Classification	Zone 1 and Zone 2 areas to (IEC) EN60079-10-1 Zone 21 and Zone 22 areas to (IEC) EN60079-10-2
Installation	(IEC) EN 60079-14
Certificate	IECEX Certificate of Conformity <b>IECEX CML 22.0070X</b> EU Type Examination Certificate <b>CML 22ATEX1473X</b> UK Type Examination Certificate <b>CML 22UKEX1474X</b>
Equipment Coding	Ex db eb IIB + H2 T* Gb -55°C ≤ Ta ≤ 55°C Ex tb IIIC T76°C Db IP6X
ATEX /UKEX Coding	⊕ II 2 GD
Ingress Protection	IP66/67

**WARNING! DO NOT OPEN WHEN AN EXPLOSIVE ATMOSPHERE IS PRESENT**

  	<p>The CE marking of this product applies to "The Electrical Equipment (Safety) Directive", "The Electromagnetic Compatibility Directive", the "Waste Electrical and Electronic Equipment Directive" and the "Equipment and Protective Systems intended for use in Explosive Atmospheres Directive". [2014/35/EU, 2014/30/EU, 2012/19/EU and 2014/34/EU respectively].</p> <p>The UKCA marking of this product applies to "The Electrical Equipment (Safety) Regulations 2016", "The Electromagnetic Compatibility Regulations 2016", the "Waste Electrical and Electronic Equipment Regulations 2012" and the "Equipment and Protective Systems intended for use in Explosive Atmospheres Regulations 2016".</p> <p>The Equipment is declared to meet the provisions of the ATEX directive (2014/34/EU) by reason of the Type Examination/EU Type Examination and meets the UK statutory requirements SI 2016 No.1107 and compliance with the Essential Health and Safety Requirements. Andrew Reid Technical Manager</p>
--	--



### SPECIAL CONDITIONS FOR SAFE USE

Flameproof joints of driver modules are not intended to be repaired.

Under certain extreme circumstances, the non-metallic parts incorporated in the enclosure of this equipment may generate an ignition-capable level of electrostatic charge. Therefore, the equipment shall not be installed in a location where the external conditions are conducive to the build-up of electrostatic charge on such surfaces (e.g. steam generation, windblown dust, etc). In addition, the equipment shall only be cleaned with a damp cloth.

### 1.0 Introduction – NeoX

The NeoX Luminaire operates from mains voltage.

This installation leaflet covers the range of ATEX and IECEx NeoX Luminaire models. These luminaires are mainly used in harsh environments and are constructed using Non-corrosive materials. Refer to the current catalogue for information on product references. The luminaires are available in 01L, 02L and 04L.

TYPICAL STANDARD WIRING

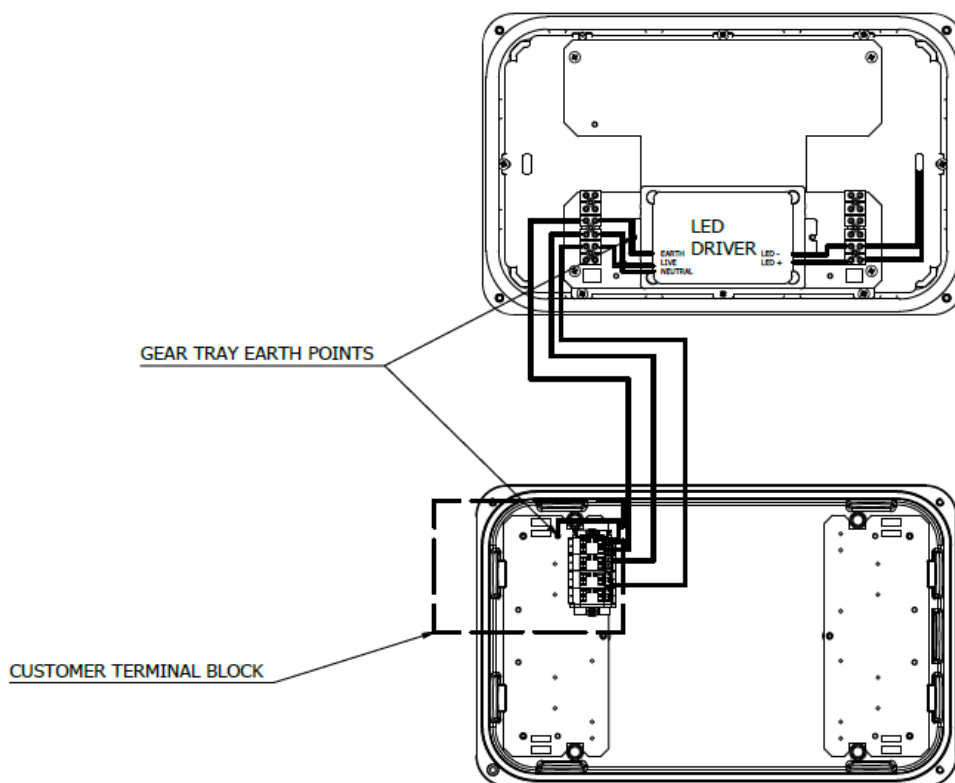

Customer Terminal Connections: LL NN EE or optional LCLC LSL S NN EE



## 2.0 Electrical Supplies

**Table 1 MODEL VARIATIONS**

Voltage range AC ==> 110-277V						
Voltage range DC ==> 127-250V						
Frequency range Hz ==> 50-60Hz						
Product	Ambient	Voltage AC	Watts	Amps	Tamb Range	T rating
NOXB/01L/LE/**	Ta25°C	110-277V	11.5W	0.12 – 0.05A	-55°C to +55°C	T6
NOXB/02L/LE/**	Ta25°C	110-277V	17.5W	0.17 – 0.07A	-55°C to +55°C	T6
NOXB/04L/LE/**	Ta25°C	110-277V	35W	0.34– 0.14A	-55°C to +55°C	T5

The safety limit for surface temperature (T rating) is +/-10% on the rated voltage. The maximum nominal variation from rated voltages stated above is +/- 6%. For the full range of Product Technical data contact Chalmit technical department

### Power Factor @230V >0.90 Over Voltage

Power is constant over voltage range.  
400V ac for 1 min and EN 61000-4-5 > 4kV

### Through Wiring

The through current rating is 16A. 4mm<sup>2</sup> terminals are standard (As option /SC 6mm<sup>2</sup> wiring can be used in the terminals in accordance with the luminaire certificate).

### Fuse and MCB Ratings

It is recommended that for selection of MCBs users should consult the MCB manufacturer as this unit contains electronic control gear. The electronic control gear has nominal values of inrush current as follows;  
**01L** 20.0A for 300µs on 230V @ Ta25°C  
**02L** 17.7A for 41µs on 230V @ Ta25°C.  
**04L** 14.5A for 28µs on 230V @ Ta25°C.

## 3.0 Storage

Luminaires are to be stored in cool dry conditions preventing ingress of moisture and condensation. Storage temperature range to be -40°C to +80°C.

## 4.0 Installation and Safety

### 4.1 General

**These instructions should be read fully and carefully before attempting to install the luminaire. For details of servicing operations, opening etc. see section 5.0**

Copies of these instructions should be held in a safe place for future reference. It is the responsibility of the installer to ensure that the apparatus selected is fit for its intended purpose and that the installation, operation and maintenance of the apparatus complies with applicable regulations, standards or codes of practice. Installation should be carried out in accordance with (IEC) *EN 60079-14* or with a local hazardous area code of practice, whichever is appropriate.

Any specific installation instructions must be referred to. In the UK the requirements of the *Health and Safety at Work Act* must be met and electrical work associated with this product must be in accordance with the "*Manual Handling Operations Regulations*" and "*Electricity at Works Regulations 1989*". Disposal instructions should be complied with. The luminaires should be considered Class 1 to EN 60598 and effectively earthed. Certification details on the rating plate must be verified against the application requirements before installation. The information in this leaflet is correct at the time of publication. The company reserves the right to make specification changes as required without notice.

#### 4.1.1 Use in Combustible Dust Atmospheres

Where the equipment is used in ignitable dust atmospheres reference must be made to the selection and installation standards in order that the equipment is used correctly. In particular this applies to the de-rating of surface temperature for use where dust clouds may be present. Dust layers should not be allowed to accumulate on the fitting surface and good housekeeping is required for safe operation. Dust in layers has the potential to form ignitable clouds and to burn at lower temperatures. Refer to EN/IEC 60079-10-2 & EN/IEC 60079-14 for additional details of selection and installation.

#### 4.1.2 Hybrid Mixtures – Gas plus Dust.

Where Hybrid mixtures exist as defined in EN1127 as a potentially explosive atmosphere, consideration should be given to verifying that the maximum surface temperature of the luminaire is below the ignition temperature of the hybrid mixture.



#### 4.2 Tools

6mm A/F socket keys (For Blanking Plugs)  
 4mm flat blade Screw Driver (For Terminal Connection)  
 5mm A/F Socket keys (For Front Access)  
 Suitable Spanners for Installing Cable Glands  
 Pliers, Knife, Wire Strippers / Cutters

#### 4.3 Mounting

Luminaires should be installed where access for maintenance is practical and in accordance with lighting design information. The standard suspension is via four M6 x 9mm deep blind tapped holes at the back of the body, the recommended torque for the fixing bolts is 10-15Nm. Various adaptors, pole clamps and suspension brackets are available to order.

#### 4.4 Electrical Supplies

A maximum voltage variation of +6%/-6% on the nominal is expected. The safety limit for T rating is +10%.

#### 4.5 Light Source

The luminaire is fitted with LEDS that can last >200,000 hours depending on ambient temperatures. Therefore, depending on the functionality of the fitting replacement of LED's will be rare / unnecessary.

#### 4.6 Cabling and Cable Glands

##### 4.6.1 Cable Glands

. The installer and user must take responsibility for the selection of cables, cable glands and seals.

The product is certified for ATEX, IECEx and UKEX and to comply with the certification for installation cable glands and sealing plugs must be ATEX, IECEx or UKEX certified depending on site requirements.

Cable glands for entry into Ex eb enclosures when fitted with any gland to body sealing method and the supply cable must reliably maintain the IP rating of the enclosure IP66/67.

The cable gland must withstand an impact value of 7Nm where the risk of mechanical damage is high or 4Nm where the risk of mechanical damage is low.

Sealing plugs must be similarly rated and a tool must be used for their removal. Where the cable is not reliably clamped externally to the apparatus, the cable gland must clamp the cable against a pull in Newtons of 20x the cable OD in mm for non-armoured cable and 80x the cable OD for armoured cable. Where brass cable glands are used in a corrosive environment cadmium or nickel plating should be used. Two tapped cable entries each end are provided, three with a plug and seal suitable for permanent use, and one has a travelling plug. M20 x 1.5 pitch entries are standard, other sizes are available on request up to M25 x 1.5 pitch

##### 4.6.2 RCG Cable Entries

The NeoX Luminaire has the option to come factory fitted with Hawke 501/RCG entries.

The installer and user must take responsibility for the selection of cables and termination of the cables with Hawke 501/RCG bodies, which are required to hook up the cable to the 501/RCG entries. 501/RCG bodies are not supplied with the luminaire.

The product is certified for ATEX, IECEx and UKEX and all factory fitted 501/RCG entries and sealing plugs have been assessed and certified in line with these requirements.

All 501/RCG entries and stopping plugs are brass nickel plated as standard. The end user should ensure that these materials are suitable for the application.

The 501/RCG entries are supplied fitted with end caps. In order to maintain IP66/67, the 501/RCG entries are required to either be fitted with the metallic end caps or be mated with a 501/RCG body.

The /RCGL version will have two 501/RCG entries on the one side of the Luminaire.

##### 4.6.3 Cable

The temperature conditions at the supply cable entry point are such that 70°C (ordinary PVC) cable can be used.

##### 4.6.4 Cable Connection

The cable connections are made by removing the main body access (Fig.1). The screws are retained and should be re-greased as required. The conductors should be bared back so that they make full contact in the terminals, but the bare conductor should not be more than 1mm beyond the terminal. Unused terminal screws should be tightened. The core must



be identified by polarity and connected in accordance with the terminal markings. Before re-fitting the cover, a final check on the correctness of connections should be made. Main body access cover screw torque 6 Nm.

#### 4.7 Electrical Connections and Testing

If any work is to be done on any luminaire already connected to the electrical system, the luminaire must be isolated from the system. The main body access (Fig.1) is swung down. To access the mains terminals loosen the 4 fixing screws. Screw type or screw-less "cage clamp" terminals are fitted in the range of luminaires. Mains terminal blocks are marked L N Earth. The maximum amount of insulation allowed beyond the throat of the terminal is 1mm. The normal method of insulation testing is to connect Live and Neutral together (suitable test unit will automatically test) and test between this point and Earth to prevent the risk of damage to the electronic control gear.

However, if this is not possible luminaires can be tested with an insulation tester that complies with IEC 364 or BS 7671 with a maximum output current of 1mA and output voltage of 500V dc. (Units damaged by incorrect insulation testing can be detected). Before completing the wiring, ensure that all the connections are correctly.

#### 5.0 Inspection, Maintenance and Servicing

**Safe servicing on the gear tray requires the mains supply to be isolated.**

Individual organisations will have their own procedures for inspection and maintenance. What follows are guidelines based on *EN/IEC 60079-17* and on our experience. Maintenance work and fault finding must be performed by competent personnel under an appropriate permit to work and with the apparatus isolated. Frequency of maintenance will depend on experience and the operating conditions.

**Luminaire should not be opened when an explosive atmosphere is present.**

- 1 Check if any LED's have failed.
- 2 The LEDs are mounted on boards, if there is 3 or more LED's not working on one board the light output will have dropped to a level where the LED board may need replaced.
- 3 Check the main body access cover screws for tightness.
- 4 Check the cable gland for tightness and re-tighten if necessary.
- 5 Check any external earthing.
- 6 Examine the LED diffuser for any signs of damage and for any signs of gasket damage, cracking or discoloration.
- 8 Check for signs of corrosion between the diffuser cover and the main housing. Evaluation of this will be a matter for judgement gained by experience, as there may be little evidence on the outside. A damaged or non-resilient gasket must be replaced (supplied by Chalmit).  
The cover should be re-fitted with all screws fully tightened. Any replacement screws must be identical to the original. Replacement fasteners should be stainless steel marine ISO262 grade A4 -70 minimum
- 9 The main body access should be opened periodically and checked for moisture and dirt ingress. The cable connections should be checked for tightness. The gasket should be checked for cracks or lack of elasticity, and if necessary, replaced. (It may well be practical to also replace the gasket on each occasion if this is at a 3-year interval). (supplied by Chalmit).
- 10 If painting operations have taken place around the luminaire, ensure that coatings have not entered or been deposited on the LED Diffuser. If they have, clean carefully.
- 11 Check that mountings are secure.
- 12 Clean the LED Diffuser.
- 13 If there is suspicion that the luminaire has suffered mechanical damage, a stringent workshop check should be made.

**Important:** *Where spares are needed, these must be replaced with manufacturer parts. No modifications should be made without the knowledge and approval of the manufacturer.*

#### 6.0 Electrical Fault Finding and Replacement

Any fault finding must be done by a competent electrician with the luminaire isolated and if carried out with the luminaire in place, under a permit to work. Fault finding is by substitution with known good components.

#### 7.0 Disposal of Material

The unit is mostly made from incombustible materials. The control gear contains electronic components and synthetic resin. All these may give off noxious fumes if incinerated. Care must be taken to render these fumes harmless and avoid inhalation. Any local regulations concerning disposal must be complied with. Any disposal must satisfy the requirements of the WEEE directive [2012/19/EU and Regulations 2012] and therefore must not be treated as commercial waste.

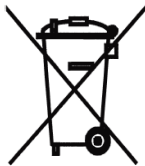

To comply with the Waste Electrical and Electronic Equipment directive 2012/19/EU and Regulations 2012 the apparatus cannot be classified as commercial waste and as such must be disposed of or recycled in such a manner as to reduce the environmental impact.

### Chalmit Lighting is a leading supplier of Hazardous Area lighting products

	<b>CHALMIT LIGHTING</b> PO Box 5575 Glasgow, G52 9AP Scotland	
Telephone: +44 (0) 141 882 5555 Fax: +44 (0) 141 883 3704 Email: info@chalmit.com Web: www.chalmit.com	Registered No: 669157 Registered Office: Cannon Place 78 Cannon Street London EC4N 6AF UK	

For technical support, please contact: techsupport@chalmit.com

Note: Chalmit Lighting reserves the right to amend characteristics of our products and all data is for guidance only.

	<b>EU/UK-Declaration of conformity</b>		
	<b>UE-Déclaration de conformité</b>		
	<b>EU-Konformitätserklärung</b>		
Manufacturer	Chalmit	Address	388 Hillington Road, Glasgow. G52 4BL Scotland UK
Product	NeoX (LED Bulkhead Luminaire)		
Notified Body	CML B.V. 2776		
EU - Type Examination Certificate	<b>CML 22ATEX1473X</b>		
Approved Body	Eurofins CML 2503		
UK Type Examination Certificate	<b>CML 22UKEX1474X</b>		
ATEX/UKEX Coding	II 2 GD		
ATEX/UKEX Classification	Group II Category 2 GD		
Equipment Coding	Ex db eb IIB + H2 T* Gb -55°C ≤ Ta ≤ 55°C Ex tb IIIC T76°C Db IP6X		
Ingress Protection	IP66/67		
The technical basis, with respect to equivalence of			
La base technique, en ce qui concerne l'équivalence de			
Die technische Grundlage hinsichtlich der Normen			
Protection Standards EN 60079-0, EN 60079-1, EN 60079-7, EN 60079-18, EN 60079-31			
Area Classification EN 60079-10-1 and EN 60079-10-2			
of compliance with the EHSRs is valid as there are no changes which materially affect the state of technological progress of the product.			
en conformité avec les EESS est valide puisqu'il n'y a aucun changement qui affecte matériellement l'état de l'évolution technologique du produit.			
zur Erfüllung der GSGA ist gegeben, da keine Änderungen erfolgt sind, die einen Einfluss auf den technischen Stand des Produkts haben.			
Terms of the directive:	Standard & Date Certified to	Standards Date Declared to	
Prescription de la directive:	Standard & date certifiée à	Normes date Déclaré	
Bestimmungen der Richtlinie:	Standard & Datum Zertifiziert nach	Standards Datum erklärt	



2014/34/EU SI 2016 No.1107	Equipment and protective systems intended for use in potentially explosive atmospheres.	EN 60079-0: 2012 A11:2013 EN 60079-1 : 2014	
2014/34/UE	Appareils et les systèmes de protection destinés à être utilisés en atmosphères potentiellement explosibles.	EN 60079-7 : 2015 EN 60079-18 : 2015 EN 60079-31: 2014	
2014/34/EU	Geräte und Schutzsysteme zur bestimmungsgemäßen Verwendung in explosionsfähigen Bereichen.		
2014/30/EU Regulations 2016	Electromagnetic compatibility	EN 55015 : 2019	
2014/30/UE	Compatibilité électromagnétique	EN 61547 : 2009	
2014/30/EU	Elektromagnetische Verträglichkeit	EN 61000-3-2 : 2019	
2014/35/EU Regulations 2016	Low voltage equipment	EN 60598-1 : 2015	
2014/35/UE	Équipements électriques à bas voltage	EN 60529 : 1992+A2:2013	
2014/35/EU	Niederspannungsgeräte / -systeme		
2012/19/EU Regulations 2012	Waste of electrical and electronic equipment		
2012/19/UE	Déchets d'équipements électriques et électroniques		
2012/19/EU	Entsorgung der elektrischen und elektronischen Geräte / Systeme		
2011/65/EU Regulations 2012	RoHS II Directive		
Additional information:	The luminaire is capable of withstanding over voltage levels of up to 400V AC for 1 minute and impulse voltage surges of 4kV.		
Informations complémentaires:	Le luminaire peut supporter des niveaux de tensions jusqu'à 400V CA pendant 1 minute et des tensions de choc de 4kV.		
Zusatzinformation :	Dieser Strahler widersteht Überspannungen bis 400V AC 1 Minute lang sowie Stoßspannungen von 4kV.		

On behalf of the Chalmit, I declare that, on the date the equipment accompanied by this declaration is placed on the market, the equipment conforms to all technical and regulatory requirements of the above listed directives.

En tant que représentant du fabricant Chalmit, je déclare qu'à la date où les équipements accompagnant cette déclaration sont mis sur le marché, ceux-ci sont conformes à toutes les dispositions réglementaires et techniques des directives énumérées ci-dessus.

Hiermit bestätige ich, im Namen von Chalmit, dass am Tag der Lieferung des Produkts/der Produkte zusammen mit dieser Erklärung das Gerät/die Geräte alle technischen und regulativen Anforderungen der oben aufgeführten Direktiven erfüllt.

Name and Date Andrew Reid 28/11/2022  
Nom et Date  
Name und Datum

Technical Manager  
Directeur technique  
Technischer Leiter

Quality Assurance Notification by: **SGS Fimko OY 0598** Quality Management System Accreditation: **ISO 9001**

Notification d'assurance qualité par: **SGS Fimko OY 0598** Système de Management Qualité Accréditation: **ISO 14001**  
Qualitätssicherungsnotifikation durch: **SGS Fimko OY 0598** Qualitätsmanagementsystem Akkreditierung: **Lloyd's Register LRQ 4005876**  
Environmental Management System.  
Système de gestion de l'environnement.  
Umwelt kontroll system.

UKCA Quality Assurance Notification by: **SGS Fimko OY 10598** Certificate No./Certificat N°/Zertifikat Nr.



**SCATTERGOOD  
& JOHNSON LTD**  
ELECTRICAL ENGINEERING & FLUID CONTROL DISTRIBUTORS

Est.1899

At Scattergood & Johnson Ltd, we pride ourselves on being a technical distributor to specialist industries.

Working with a range of quality product manufacturers across a number of specialist markets, we are not your average 'box shifter' - we are your technical and supply chain partner.

We fully support every product we sell - for free! Our internal team and external sales engineers can answer any product or application question, no matter the complexity.

Backing up this technical ability is a range of 50,000+ products available from stock for nationwide next day delivery (same day if required!), or you can collect what you need from any of our trade counters around the UK.

Select your specialist interest below to learn more about how we can help.



Online, In Branch and On the Road - Scattergood & Johnson Ltd, there when you need us.

**[www.scatts.co.uk](http://www.scatts.co.uk)**