

ENCLOSURE HEATER

LPS 164 | 10 W to 50 W

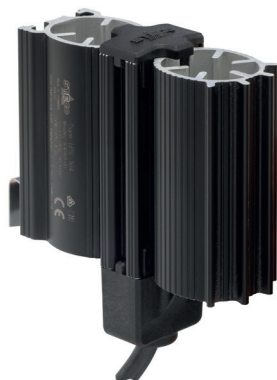

- > Clip fixing for quick mounting
- > Dynamic heating up through PTC technology
- > Heater body in loop design for optimal temperature distribution
- > Wide voltage range
- > Additional approvals

Compact heater with PTC heating elements for heating enclosures with electrical or electronic components. The heater prevents too low temperatures and thus condensation harming the components. The design of the aluminium profile creates a chimney effect, which ensures even temperature distribution within the enclosure. The heaters are designed for continuous operation.

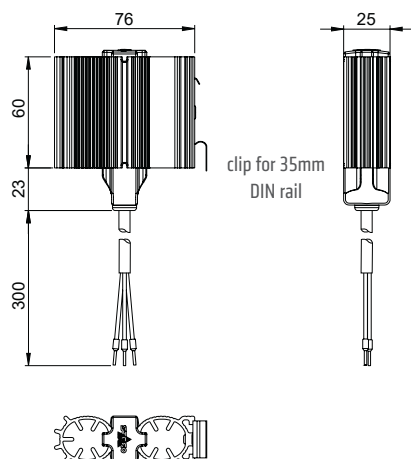

TECHNICAL DATA

Operating voltage	AC/DC 120-240 V (min. 110 V, max. 265 V)
Heating element	PTC resistor - temperature limiting
Heater body	aluminium profile, anodised
Connection	3 x 0.5 mm ² x 300 mm cable
Dimensions	83 x 25 x 76 mm
Mounting	clip for 35 mm DIN rail, EN 60715
Fitting position	vertical airflow (air outlet up, connection on bottom)
Weight	~ 0.2 kg
Operating/Storage temperature	-45 to +70 °C (-49 to +158 °F)
Operating/Storage humidity	< 90 % RH (non-condensing)
Protection type/Protection class	IP20 / I (earthed)
Note	other voltages on request



Example of connection

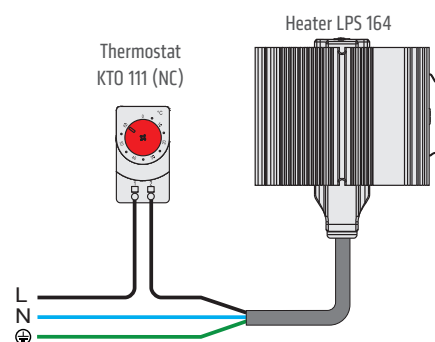

Art. No.	Heating capacity ¹	Inrush current max.	Recommended pre-fuse T (time-delay)	Approvals	
16400.0-00	10 W	2.0 A	4.0 A	VDE	EAC
16401.0-00	20 W	2.0 A	4.0 A	VDE	EAC
16402.0-00	30 W	2.0 A	4.0 A	VDE	EAC
16403.0-00	40 W	4.0 A	6.0 A	VDE	EAC
16404.0-00	50 W	4.0 A	6.0 A	VDE	EAC
16400.9-00	10 W	2.0 A	4.0 A	UL ²	EAC
16401.9-00	20 W	2.0 A	4.0 A	UL ²	EAC
16402.9-00	30 W	2.0 A	4.0 A	UL ²	EAC
16403.9-00	40 W	4.0 A	6.0 A	UL ²	EAC
16404.9-00	50 W	4.0 A	6.0 A	UL ²	EAC

¹ measured at +20 °C (+68 °F) ambient temperature; ² according to UL 508 A, File No. E234324



**SCATTERGOOD
& JOHNSON LTD**
ELECTRICAL ENGINEERING & FLUID CONTROL DISTRIBUTORS

Est.1899

At Scattergood & Johnson Ltd, we pride ourselves on being a technical distributor to specialist industries.

Working with a range of quality product manufacturers across a number of specialist markets, we are not your average 'box shifter' - we are your technical and supply chain partner.

We fully support every product we sell - for free! Our internal team and external sales engineers can answer any product or application question, no matter the complexity.

Backing up this technical ability is a range of 50,000+ products available from stock for nationwide next day delivery (same day if required!), or you can collect what you need from any of our trade counters around the UK.

Select your specialist interest below to learn more about how we can help.



Online, In Branch and On the Road - Scattergood & Johnson Ltd, there when you need us.

www.scatts.co.uk