

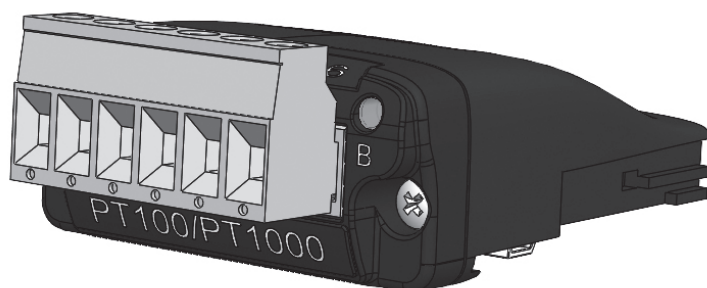

Member of **Sumitomo Drive Technologies**

PT100/PT1000 Module

OPT-2-PTXIN-IN



Overview

The OPT-2-PTXIN-IN is an internal option module which provides two additional inputs for compatible drives, to monitor external temperatures via PT100 or PT1000 sensors.

Note

This User Guide is intended to be used with Optidrive P2 & Eco firmware version 2.50 or later. The firmware version of the drive can be displayed in parameter P0-28. Previous versions of firmware can be upgraded using Optitools Studio PC software. Contact your local Inverter Sales Partner for further information.

1.1. OPT-2-PTXIN-IN

1.1.1. General Information

It is the responsibility of the installer to ensure that the equipment or system into which the product is incorporated complies with all relevant legislation and codes of practice which apply in the country of use.

1.1.2. CE Marking

All Invertek Drives products intended for use within the European Union carry the CE mark to indicate compliance with European Directives. A declaration of conformity is available from the website, www.invertekdrives.com

For compliance with the European EMC Directive, the necessary guidance is provided within this document and it is the responsibility of the installer to ensure this guidance is followed to ensure compliance.

1.1.3. UKCA Marking

All Invertek Drives products intended for use within the United Kingdom carry the UKCA mark to indicate compliance with the relevant UK regulations (Including: Electromagnetic Compatibility Regulations). A declaration of conformity is available from the website, www.invertekdrives.com. For compliance with the relevant sections of the above regulations, the necessary guidance is provided within this document and it is the responsibility of the installer to ensure this guidance is followed to ensure compliance.

1.1.4. Overview

The OPT-2-PTXIN-IN is an internally installed terminal option card which provides an additional two PT100 or PT1000 input for compatible drives, to monitor external temperatures. The inputs are automatically detected as PT100 or PT1000 based on the resistance measurement and a combination of PT100 and PT1000 sensors can be used on the same card. The temperature measurement can be read back via the scope channels 84 and 85 or as a data input in the built-in plc program.

1.1.5. Compatibility with Current Products

OPT-2-PTXIN-IN is compatible with all ODP-2 and ODV-3 models (regardless of the IP rating of the drive).

1.1.6. Electrical Specification

Number of temperature sensor inputs:	2
Signal Type:	PT100/1000 (auto-select)
Connection:	2 wire and 3-wire support
Update frequency:	1Hz (for each channel)
Resolution:	10bit (1°C)
Temperature range:	-50 to 204°C (PT100) / -58 to 399°C (PT1000)
Insulation level:	2kV
Maximum signal cable length:	500m

1.1.7. Mechanical Installation

- Ensure the drive power is removed prior to installing the option module
- Remove the blanking cover from the option module slot
- Carefully slide the option module into the slot, ensuring that the locating tabs are correctly aligned. Do not use excessive force
- Tighten the 2 clamping screws to secure the module in place

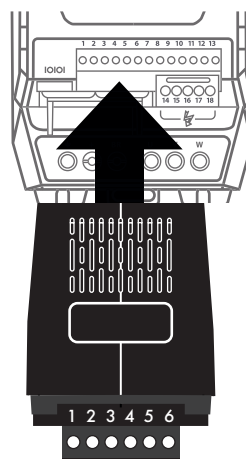

1.1.8. Option Module Connection Terminals

T	Function	Description	
1	+R1	Positive Connection	Sensor 1
2	-RL1	Wire Resistance Compensation	
3	-R1	Negative Connection	
4	+R2	Positive Connection	Sensor 2
5	-RL2	Wire Resistance Compensation	
6	-R2	Negative Connection	

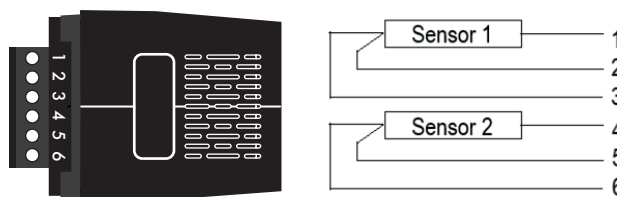

NOTE To minimise on any noise injection into the drive control circuit, ensure that the PT100/PT1000 sensors connected are isolated from power earth (ground).

1.2. Status LEDs

The PT100/PT1000 module has two status LED's to aid diagnostics, the LED operation is described below:

LED A Illuminated if Sensor 1 is connected and measured resistance is within range.

LED B Illuminated if Sensor 2 is connected and measured resistance is within range.

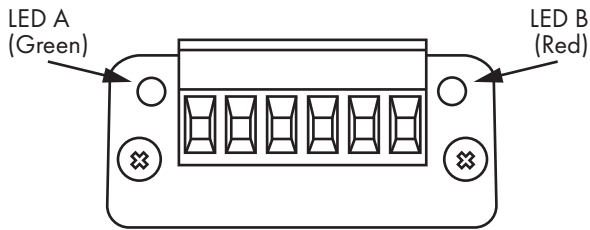

If either LED is not illuminated, the corresponding sensor is not connected correctly or damaged. Check that the connections are made correctly as shown above or replace the sensor.

1.3. Reading back the Sensor Temperature and Status

The temperature measured by the sensor can be read back in units of °C using the plc program in OptiTools Studio or reading the PO-80 Index parameter.

1.3.1. Reading back the Sensor Temperature and Status on the Drive Keypad

The PO-80 index can be read by setting P6-28 to the index value and then reading back the displayed value in PO-80 as follows:

P6-28 Setting	PO-80 Display Value
94	Sensor 1 Temperature in Deg C
95	Sensor 2 Temperature in Deg C

Please note that the PO-80 displayed value is unsigned so only temperatures of zero degrees C or above will display correctly here without any further interpretation of the value.

In addition to this, the sensor status can be read back using PO-03 by looking at DI6 (sensor 1) and DI7 (sensor 2) status. A value of 1 would indicate sensor connected and measurement within range, a value of 0 would indicate either sensor not connected or measurement out of range. DI6 and DI7 status can be read on the drive display by reading PO-03 as follows:

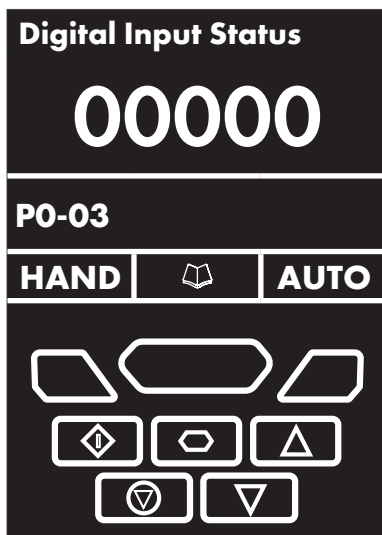

Select PO-03 and view the value to see the Digital Input Status as shown above.

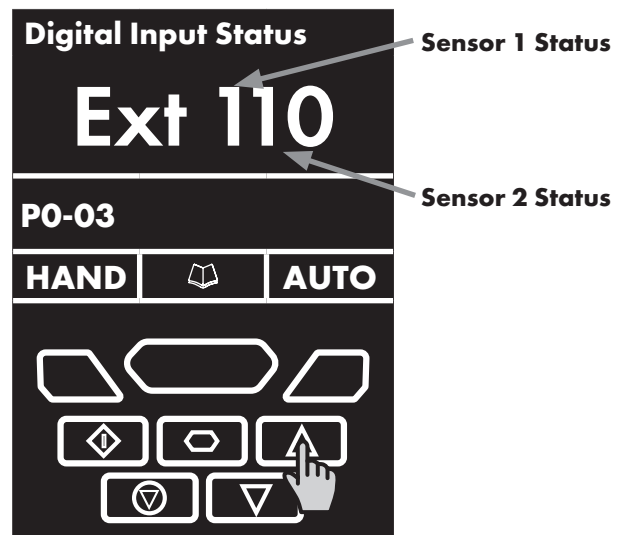

Pressing the arrow up to reach the extended I/O status.

The drive will now display the extended inputs (DI6, DI7 & DI8). The first digit to the left would indicate the status of Sensor 1 and the next digit would indicate the status of Sensor 2.

1.3.2. Reading back the Sensor Temperature and Status using the on-board PLC

In the Function Block Editor, the temperature measured by each sensor can be read and processed from a Data Input as shown below:

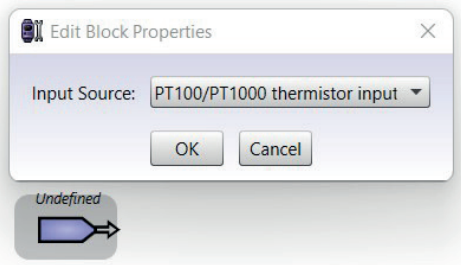

Double clicking on the data input can allow you to select the source as the PT100/PT1000 thermistor input.

NOTE There are two PT100/PT1000 inputs to select from, ensure that you select the correct one for your installation/application.

An example program is shown below where if the drive is NOT in Editing Mode, AND the UP Button is pressed, the temperature measured by Sensor 1 will be displayed in Degrees C. When the UP Button is released, the display will return to the standard mode. In a similar way, if the drive is NOT in Editing Mode, AND the DOWN Button is pressed, the temperature measured by Sensor 2 will be displayed in Degrees C. When the DOWN Button is released, the display will return to the standard mode.

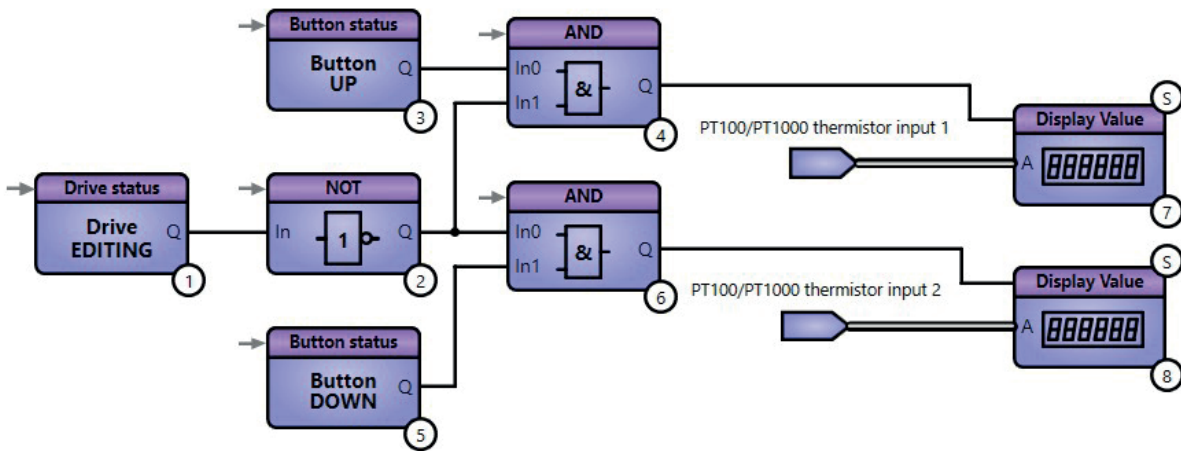

The display Value block should be set to signed and the units applied as Celsius as shown below:

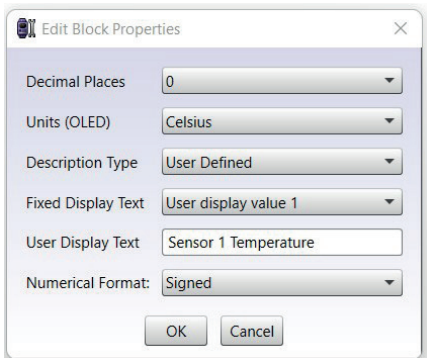

The Sensor Input Status could also be monitored for signal loss or error by monitoring DI6 (Sensor 1) or DI7 (Sensor 2) as illustrated below:

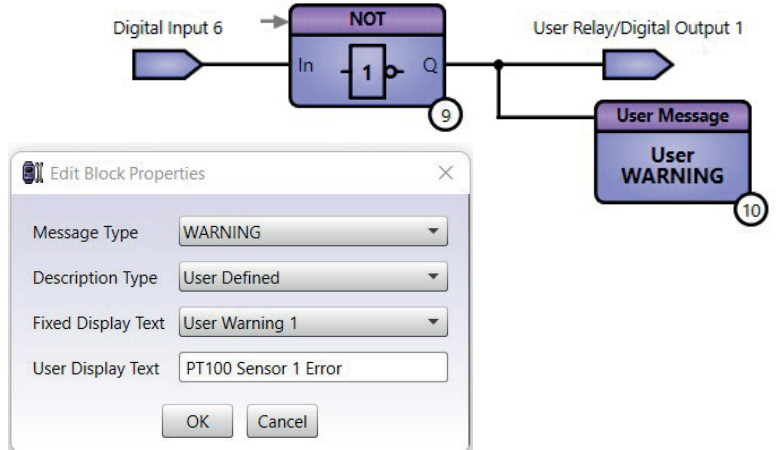

In the above example, the drive relay would change state if the sensor is disconnected and a warning displayed on the drive.

NOTE The relay source must be changed to User Defined using P9-35 (P9-36 for relay 2) for this feature to work.



82-PTXIN-IN_V1.00



**SCATTERGOOD
& JOHNSON LTD**
ELECTRICAL ENGINEERING & FLUID CONTROL DISTRIBUTORS

Est.1899

At Scattergood & Johnson Ltd, we pride ourselves on being a technical distributor to specialist industries.

Working with a range of quality product manufacturers across a number of specialist markets, we are not your average 'box shifter' - we are your technical and supply chain partner.

We fully support every product we sell - for free! Our internal team and external sales engineers can answer any product or application question, no matter the complexity.

Backing up this technical ability is a range of 50,000+ products available from stock for nationwide next day delivery (same day if required!), or you can collect what you need from any of our trade counters around the UK.

Select your specialist interest below to learn more about how we can help.



Online, In Branch and On the Road - Scattergood & Johnson Ltd, there when you need us.

www.scatts.co.uk