



Solenoid Driver

KFD2-SLD-Ex2.1045

- 2-channel isolated barrier
- 24 V DC supply (bus or loop powered)
- Output 45 mA at 10 V DC
- Line fault transparency (LFT)
- Test pulse immunity
- Up to SIL 3 acc. to IEC/EN 61508



SIL 3



Function

This isolated barrier is used for intrinsic safety applications.

The device supplies power to solenoids, LEDs and audible alarms located in the explosion-hazardous area.

The device is controlled with a loop powered signal or a bus powered logic signal.

The device is immune to the test pulses of various control systems.

The device simulates a minimum load at the input. The minimum load is set via the mode of operation. In the loop-powered mode of operation, a minimum load of 35 mA is simulated. In the bus-powered mode of operation, a minimum load of 5 mA is simulated.

The line fault transparency function can display a line fault in the field by a change in impedance at the switching input of the solenoid driver.

A fault is indicated by LEDs and output via a fault indication output.

Connection

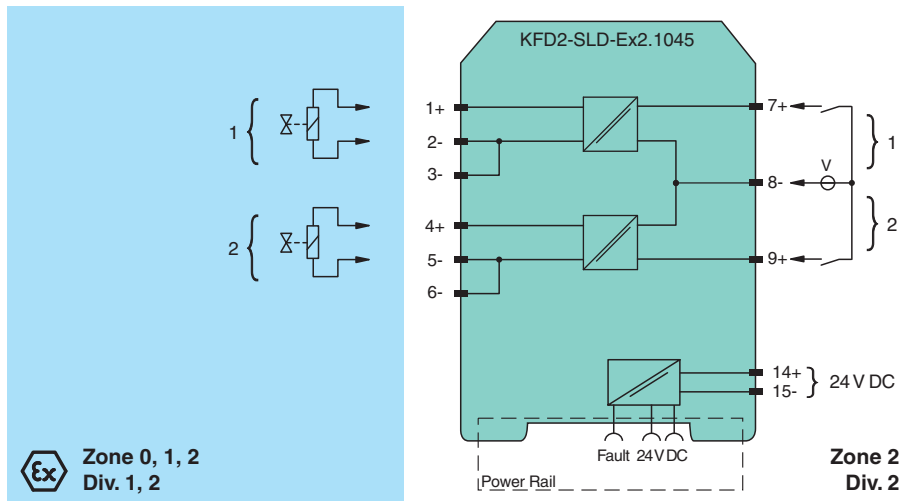

Technical Data

General specifications

Signal type Digital Output

Functional safety related parameters

Safety Integrity Level (SIL) SIL 3

Systematic capability (SC) SC 3

Supply

Connection Power Rail or terminals 14+, 15-

Rated voltage U_r 18 ... 30 V DC

Power consumption max. 3.5 W at 45 mA output current

Input

Release date: 2023-03-28 Date of issue: 2023-03-28 Filename: 70153575_eng.pdf

Refer to "General Notes Relating to Pepperl+Fuchs Product Information".

Pepperl+Fuchs Group
www.pepperl-fuchs.com

USA: +1 330 486 0002
pa-info@us.pepperl-fuchs.com

Germany: +49 621 776 2222
pa-info@de.pepperl-fuchs.com

Singapore: +65 6779 9091
pa-info@sg.pepperl-fuchs.com

PF PEPPERL+FUCHS

Technical Data

Connection side		control side
Connection		terminals 7, 8, 9
Test pulse length		max. 2 ms from DO card
Signal level		loop powered 1-signal: 18 ... 30 V DC 0-signal: 0 ... 5 V DC bus powered 1-signal: 15 ... 30 V DC (current limited at 5 mA) 0-signal: 0 ... 5 V DC
Rated current	I_r	0-signal: typ. 1.6 mA at 1.5 V DC; typ. 8 mA at 3 V DC (maximum leakage current DO card) 1-signal: ≥ 35 mA (minimum load current DO card)
Inrush current		≤ 200 mA after 100 μ s
Output		
Connection side		field side
Connection		channel 1: terminals 1+, 2-, 3- channel 2: terminals 4+, 5-, 6-
Internal resistor	R_i	276 Ω
Current	I_e	45 mA
Voltage	U_e	≥ 10 V
Open loop voltage	U_s	min. 23.6 V
Load		nominal 0.05 ... 20 k Ω
Energized/De-energized delay		≤ 20 ms / ≤ 20 ms
Line fault detection		signal at short-circuit $R_{load} < 25 \Omega$, lead breakage $R_{load} > 50 \text{ k}\Omega$; test current $< 500 \mu\text{A}$
Galvanic isolation		
Input/Output		reinforced insulation according to IEC/EN 61010-1, rated insulation voltage 300 V_{eff}
Power supply/Output		reinforced insulation according to IEC/EN 61010-1, rated insulation voltage 300 V_{eff}
Indicators/settings		
Display elements		LEDs
Control elements		DIP switch
Configuration		via DIP switches
Labeling		space for labeling at the front
Directive conformity		
Electromagnetic compatibility		
Directive 2014/30/EU		EN 61326-1:2013 (industrial locations)
Conformity		
Electromagnetic compatibility		NE 21:2017, EN IEC 61326-1:2021 (industrial locations), EN IEC 61326-3-2:2018 For further information see system description.
Ambient conditions		
Ambient temperature		-40 ... 60 $^{\circ}\text{C}$ (-40 ... 140 $^{\circ}\text{F}$) extended ambient temperature range up to 70 $^{\circ}\text{C}$ (158 $^{\circ}\text{F}$), refer to manual for necessary mounting conditions
Mechanical specifications		
Degree of protection		IP20
Connection		screw terminals
Mass		approx. 150 g
Dimensions		20 x 119 x 115 mm (0.8 x 4.7 x 4.5 inch) (W x H x D), housing type B2
Mounting		on 35 mm DIN mounting rail acc. to EN 60715:2001
Data for application in connection with hazardous areas		
EU-type examination certificate		FIDI 21 ATEX 0091 X
Marking		Ⓜ II 3(1)G Ex ec [ia Ga] IIC T4 Gc Ⓜ II (1)D [Ex ia Da] IIIC Ⓜ I (M1) [Ex ia Ma] I
Output		Ex ia
Voltage	U_o	25.2 V
Current	I_o	93 mA
Power	P_o	586 mW (linear characteristic)
Supply		

Release date: 2023-03-28 Date of issue: 2023-03-28 Filename: 70153575_eng.pdf

Refer to "General Notes Relating to Pepperl+Fuchs Product Information".

 Pepperl+Fuchs Group
www.pepperl-fuchs.com

 USA: +1 330 486 0002
pa-info@us.pepperl-fuchs.com

 Germany: +49 621 776 2222
pa-info@de.pepperl-fuchs.com

 Singapore: +65 6779 9091
pa-info@sg.pepperl-fuchs.com

 **PEPPERL+FUCHS**

Technical Data

Maximum safe voltage	U_m	250 V (Attention! The rated voltage can be lower.)
Input		
Maximum safe voltage	U_m	250 V (Attention! The rated voltage can be lower.)
Collective error message		
Maximum safe voltage	U_m	250 V (Attention! The rated voltage can be lower.)
Galvanic isolation		
Input/Output		safe electrical isolation acc. to IEC/EN 60079-11, rated insulation voltage 300 V_{rms}
Output/power supply		safe electrical isolation acc. to IEC/EN 60079-11, rated insulation voltage 300 V_{rms}
Directive conformity		
Directive 2014/34/EU		EN IEC 60079-0:2018+AC:2020 , EN 60079-7:2015+A1:2018 , EN 60079-11:2012
International approvals		
UL approval		E106378
Control drawing		116-0488
IECEX approval		
IECEX certificate		IECEX FIDI 21.0009X
IECEX marking		Ex ec [ia Ga] IIC T4 Gc [Ex ia Da] IIC [Ex ia Ma] I
General information		
Supplementary information		Observe the certificates, declarations of conformity, instruction manuals, and manuals where applicable. For information see www.pepperl-fuchs.com .

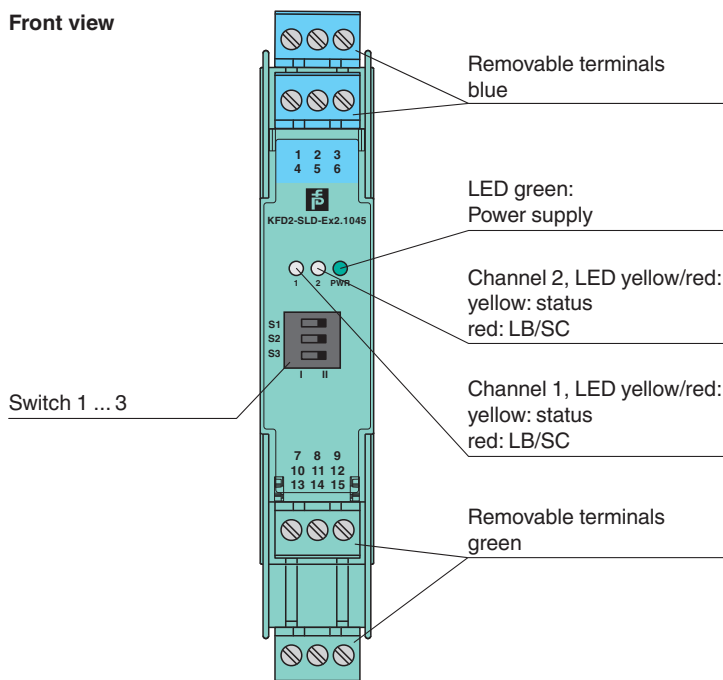

Assembly

Front view



Release date: 2023-03-28 Date of issue: 2023-03-28 Filename: 70153575_eng.pdf

Matching System Components

	KFD2-EB2	Power Feed Module
	UPR-03	Universal Power Rail with end caps and cover, 3 conductors, length: 2 m

Refer to "General Notes Relating to Pepperl+Fuchs Product Information".

Pepperl+Fuchs Group
www.pepperl-fuchs.com





USA: +1 330 486 0002
pa-info@us.pepperl-fuchs.com

Germany: +49 621 776 2222
pa-info@de.pepperl-fuchs.com



Singapore: +65 6779 9091
pa-info@sg.pepperl-fuchs.com

 **PEPPERL+FUCHS**

Matching System Components

	UPR-03-M	Universal Power Rail with end caps and cover, 3 conductors, length: 1,6 m
	UPR-03-S	Universal Power Rail with end caps and cover, 3 conductors, length: 0.8 m
	K-DUCT-BU	Profile rail, wiring comb field side, blue
	K-DUCT-BU-UPR-03	Profile rail with UPR-03- * insert, 3 conductors, wiring comb field side, blue

Accessories

	KF-ST-5GN	Terminal block for KF modules, 3-pin screw terminal, green
	KF-ST-5BU	Terminal block for KF modules, 3-pin screw terminal, blue
	KF-CP	Red coding pins, packaging unit: 20 x 6

Configuration

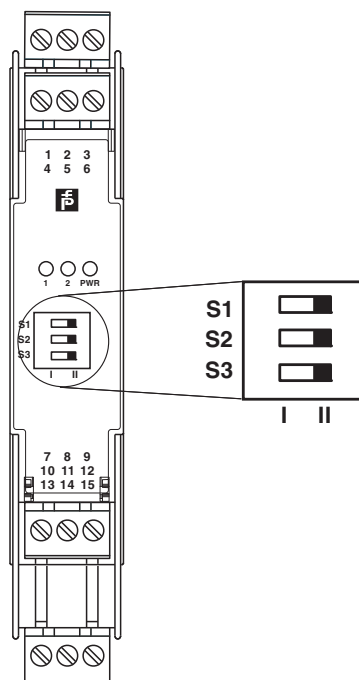

Switch settings

Switch	Function		Position
S1	Line fault detection	enabled	I
		disabled	II
S2	Mode of operation channel 1	loop powered	I
		bus powered	II
S3	Mode of operation channel 2	loop powered	I
		bus powered	II

Factory setting: line fault detection enabled, mode of operation loop powered

Characteristic Curve

Output characteristics

Output circuit diagram

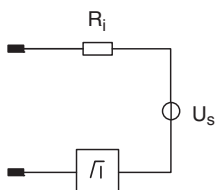

Output characteristic

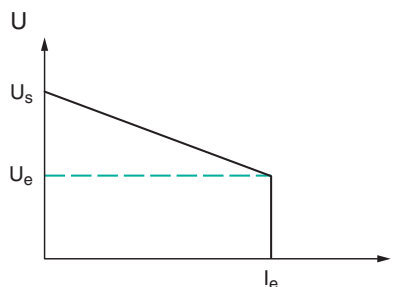

Release date: 2023-03-28 Date of issue: 2023-03-28 Filename: 70153575_eng.pdf

Refer to "General Notes Relating to Pepperl+Fuchs Product Information".



**SCATTERGOOD
& JOHNSON LTD**
ELECTRICAL ENGINEERING & FLUID CONTROL DISTRIBUTORS

Est.1899

At Scattergood & Johnson Ltd, we pride ourselves on being a technical distributor to specialist industries.

Working with a range of quality product manufacturers across a number of specialist markets, we are not your average 'box shifter' - we are your technical and supply chain partner.

We fully support every product we sell - for free! Our internal team and external sales engineers can answer any product or application question, no matter the complexity.

Backing up this technical ability is a range of 50,000+ products available from stock for nationwide next day delivery (same day if required!), or you can collect what you need from any of our trade counters around the UK.

Select your specialist interest below to learn more about how we can help.



Online, In Branch and On the Road - Scattergood & Johnson Ltd, there when you need us.

www.scatts.co.uk