

# UPS-BAT/PB/24DC/40AH - Energy storage



1354641

<https://www.phoenixcontact.com/gb/products/1354641>

Please be informed that the data shown in this PDF document is generated from our online catalog. Please find the complete data in the user documentation. Our general terms of use for downloads are valid.

---



Energy storage, VRLA-AGM, 24 V DC, 40 Ah, automatic detection and communication with QUINT UPS-IQ

## Product description

For continuous monitoring and intelligent management, there is constant communication with the QUINT UPS. Thanks to automatic detection of the energy storage, and tool-free switching during operation, quick installation is possible. The QUINT UPS with IQ technology energy storage leaves the warehouse fully charged.

## Your advantages

- Maximum buffer times
- Consists of 2 x 12 V battery modules and an electronic monitoring unit
- Lead AGM (Absorbent Glass Mat) technology

# UPS-BAT/PB/24DC/40AH - Energy storage



1354641

<https://www.phoenixcontact.com/gb/products/1354641>

## Technical data

### Energy storage

#### Input

Input voltage	24 V DC (SELV)
Nominal capacity	40 Ah
Charging current	12 A
End-of-charge voltage	27.6 V (20 °C)

#### Output

Output current $I_{\max}$	45 A
Output fuse	2x 25 A
Buffer time	82 min. (20 A)
	35 min. (40 A)

#### General

Connection in parallel	yes
	max. 5
Battery type	BB Battery BP 40-12FR
Battery technology	VRLA-AGM
IQ-Technology	yes
Latest startup date (battery only)	12 Months (0 °C ... 20 °C)
Latest startup (battery only) - range	9 Months ... 12 Months (20 °C ... 30 °C)
	6 Months ... 9 Months (30 °C ... 40 °C)
Accumulator module service life (according to Eurobat)	8 (20 °C)
Size designation	Block
Battery pack	yes
Suitable for fast charging	yes
Temperature sensor	yes
Number of replacement battery kits	1x (UPS-BAT-KIT/PB/2X12V/40AH (1383182))
Disposal	Used batteries must not be thrown away with household waste, they should instead be disposed of in accordance with applicable national regulations.

### Connection data

#### Conductor connection

Connection method	Push-in connection
-------------------	--------------------

### Product properties

Product type	Battery unit
Product family	Energy storage
Application	for QUINT4 DC-UPS, QUINT4 AC-UPS, QUINT-UPS, and TRIO-UPS-2G
Disposal	Used batteries must not be thrown away with household waste,

## UPS-BAT/PB/24DC/40AH - Energy storage



1354641

<https://www.phoenixcontact.com/gb/products/1354641>

they should instead be disposed of in accordance with applicable national regulations.

## Insulation characteristics

Protection class	III
Degree of pollution	2

## Dimensions

## Item dimensions

Width	333 mm
Height	173 mm
Depth	199 mm

## Drill hole

Diameter	5 mm
----------	------

## Mounting

Mounting position	Horizontally, on a mounting panel
-------------------	-----------------------------------

## Material specifications

Housing material	Plastic
------------------	---------

## Cable/line

## Battery connecting cable:

Cable cross section	6 mm <sup>2</sup>
Cable length	340 mm
Color	red/black

## Battery connecting cable:

Cable cross section	6 mm <sup>2</sup>
Cable length	110 mm
Color	red/black

## Environmental and real-life conditions

## Ambient conditions

Degree of protection	IP20
Ambient temperature (storage/transport)	-20 °C ... 40 °C
Ambient temperature (charge)	0 °C ... 40 °C
Ambient temperature (discharge)	-20 °C ... 50 °C
Max. permissible relative humidity (operation)	≤ 95 %

## Ex data

Suited for EX-applications	No
----------------------------	----

## UPS-BAT/PB/24DC/40AH - Energy storage



1354641

<https://www.phoenixcontact.com/gb/products/1354641>

## Drawings

Block diagram

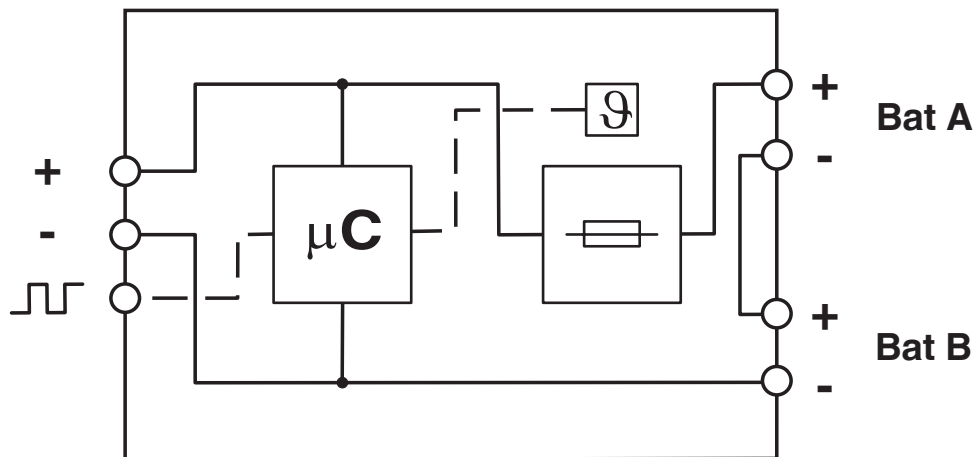

Block diagram

Phoenix Contact 2023 © - all rights reserved  
<https://www.phoenixcontact.com>

PHOENIX CONTACT Ltd  
 Halesfield 13, Telford  
 Shropshire, TF7 4PG  
 01952 681700  
[info@phoenixcontact.co.uk](mailto:info@phoenixcontact.co.uk)



**SCATTERGOOD  
& JOHNSON LTD**  
ELECTRICAL ENGINEERING & FLUID CONTROL DISTRIBUTORS

Est.1899

At Scattergood & Johnson Ltd, we pride ourselves on being a technical distributor to specialist industries.

Working with a range of quality product manufacturers across a number of specialist markets, we are not your average 'box shifter' - we are your technical and supply chain partner.

We fully support every product we sell - for free! Our internal team and external sales engineers can answer any product or application question, no matter the complexity.

Backing up this technical ability is a range of 50,000+ products available from stock for nationwide next day delivery (same day if required!), or you can collect what you need from any of our trade counters around the UK.

Select your specialist interest below to learn more about how we can help.



Online, In Branch and On the Road - Scattergood & Johnson Ltd, there when you need us.

**[www.scatts.co.uk](http://www.scatts.co.uk)**