

INSTALLATION MANUAL

RTU-LP-ST

RTU / Datalogger Low Power with
embedded modem GSM/GPRS and I/O



 **SENECA**[®]

SENECA S.r.l.

Via Austria 26 - 35127 - Z.I. - PADOVA (PD) - ITALY
Tel. +39.049.8705359 - 8705355 Fax +39 049.8706287

www.seneca.it

RTU-LP-ST | RTU / Datalogger Low Power with embedded modem GSM/GPRS and I/O

Z



The full content of this Manual must be read before performing any operation.

The module must only be used by qualified electricians. Specific documentation is available from www.seneca.it



The module must be repaired and damaged parts replaced by the Manufacturer. The product is sensitive to electrostatic discharges. Take appropriate measures during all operations.



The warranty is null and void in the event the module or devices supplied by the Manufacturer, necessary for its correct operation, are improperly used or tampered with and, in any case, if the instructions contained in this manual were not followed.



Electrical and electronic waste disposal (applicable in the European Union and other countries with recycling).
The symbol on the product or its packaging shows the product must be surrendered to a collection centre authorized to recycle **electrical and electronic waste**.

This document is the property of SENECA srl. Unauthorized duplication and reproduction is strictly forbidden. The content of this document corresponds to the described products and technologies. Stated data may be modified or supplemented for technical and/or sales purposes.

RTU-LP DESCRIPTION



The RTU-LP-ST is a device used to tele-control digital and analogue data via GSM/GPRS connections. The system architecture is based on a microcontroller, an in-built modem and a range of inputs/outputs. RTU-LP-ST is suitable for all the telecontrol applications on small systems, system parts, data collection and management.

The many accessories such as external aerials, IP65, IP67 protection casings or battery packs with increased capacity, guarantee a customisable and complete offer for industrial applications.

RTU-LP-ST | RTU / Datalogger Low Power with embedded modem GSM/GPRS and I/O**INSTALLATION REGULATIONS**

In addition to the installation on an IEC EN 60715 omega rail using the S-DIN support with screws supplied, the RTU-LP device can be housed in an IP65 pre-wired housing (BOX-RTU-IP65) with battery support and dimensions 290x140x108mm.

Check the order codes in the SOFTWARE and ACCESSORIES paragraph on page 8.

	For the wiring, use only a cable compliant with the national or harmonised regulations, having a section suitable to the device consumption and the installation conditions. Use power cables with a minimum section of 0.25mm ² .
	If external batteries are used, the power cable maximum length must not exceed 3 meters.
	It is MANDATORY to use an antenna with coaxial cable positioned at minimum 50cm from the unit.

FACTORY SETTINGS

The RTU-LP device has no factory settings: To proceed with the first configuration, it is necessary to use the EASY RTU LP software that can be downloaded free of charge from the software section of the product sheet www.seneca.it/products/rtu-lp-st

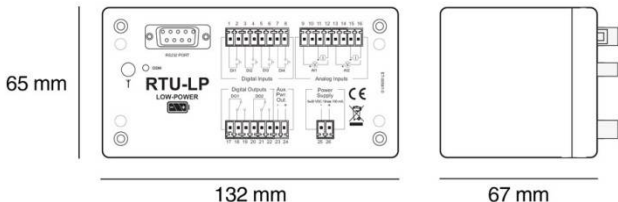
MODULE DIMENSIONS

Dimension (WxHxD)	132 x 65 x 67 mm
Weight	290 g
Case	ABS, black

RTU-LP-ST | RTU / Datalogger Low Power with embedded modem GSM/GPRS and I/O**TECHNICAL SPECIFICATIONS****POWER SUPPLY**

<i>Voltage</i>	8..30 Vdc
<i>Absorption</i>	3.7 mW (no TX, no AUX PWR and inputs OFF). 5 W PEAK DURING tx
<i>Sensor auxiliary supply</i>	100 mA maximum • for external loop-powered sensors with automatic pre-start function.

AUTONOMY

Life with 13,000 mA/h @ 10,8V (*) Lithium-thionyl Chloride batteries up to 3 years.

FUNCTIONALITY

- Data transmission on event or request.
- Temporary switching on for message reception and/or sending and temporary switching on on event
- Datalogger with 2MB internal Flash memory
- Maximum analogue log speed: 30 sec.
- Maximum digital log speed: 1 sec.

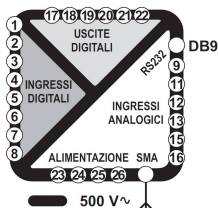
INSULATION**DIGITAL INPUTS**

4 galvanically insulated with 1 Hz sampling frequency
4 x 32 bit totalizers (maximum 1 Hz).

DIGITAL OUTPUTS

2 with bistable relays
Capacity: 30 Vdc / 1 A Max (resistive load)

ANALOGUE INPUTS

2 in Voltage (± 50 V, ± 20 V, ± 2 V) or Current (± 20 mA)
Resolution: 15 bit + sign
Precision: 0.1% F.S. at 20°C
Input impedance: > 1 MOhm

CPU MEMORIES and

ARM 32 bit, EEPROM: 64 kB, FLASH: 2 MB

CLOCK

Internal RTC; max error: 75 ppm (-20 – 70°C)

IN-BUILT MODEM

GSM/GPRS quad-band 850/900/1800/1900 MHZ
GPRS multi slot class 10, GPRS max. speed 86 kbps (DL)
Coding scheme CS-1, CS-2, CS-3, CS-4.

RTU-LP-ST | RTU / Datalogger Low Power with embedded modem GSM/GPRS and I/O**TECHNICAL SPECIFICATIONS**

COMMUNICATION PORT	1 RS232 half duplex
PROTOCOLS	ModBUS RTU SMS protocol FTP protocol to send the Log
CONNECTIONS	DB9F connector for RS232 SMA-F antenna connector I/O connectors: Removable terminals pitch = 3.5mm
AMBIENT CONDITIONS	
<i>Operating temperature</i>	-20°C – +70°C
<i>Humidity</i>	30 – 90% to 40°C non condensing
<i>Altitude</i>	up to 2000 m above sea level
<i>Storage temperature</i>	-20°C – +85°C
<i>Protection rating</i>	IP40 (without optional outside container)
STANDARDS	EN 61000-6-4 Electromagnetic Emission, industrial environment. EN 61000-6-2 Electromagnetic Immunity, industrial environment. EN 301 511 Harmonized standard for mobile stations in the GSM900 and 1800 bands. EN 301 489-1 Electro-Magnetic Compatibility standard for radio equipment and services EN 301 489-7 Specific (EMC) conditions for mobile radio equipment (GSM 900 and 1800). EN 60950 Safety of information Technology Equipment.

(*) with 1 SMS transmitted a day, all inputs OFF, no sensor auxiliary power and no RS232 serial communication.

LED SIGNALLING THE STATUS OF THE GSM NETWORK

Fast flashing	Network search / SIM not connected
Slow flashing	GSM transmitting
ON	Data connection
OFF	GSM not operating

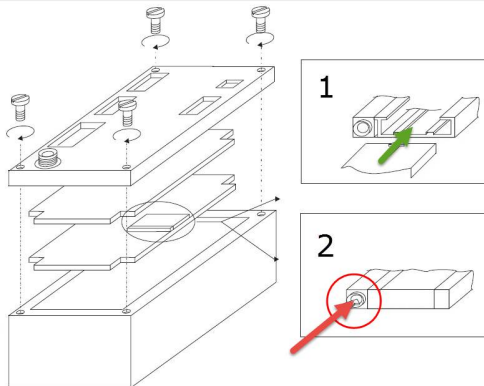
RTU-LP-ST | RTU / Datalogger Low Power with embedded modem GSM/GPRS and I/O**OPENING THE CASE AND INSERTING THE SIM CARD**

After removing the 4 screws with a screwdriver, follow the instructions in the picture above: to insert the SIM card, follow figure 1; to remove it, press the button on the side of the slot as shown in figure 2.

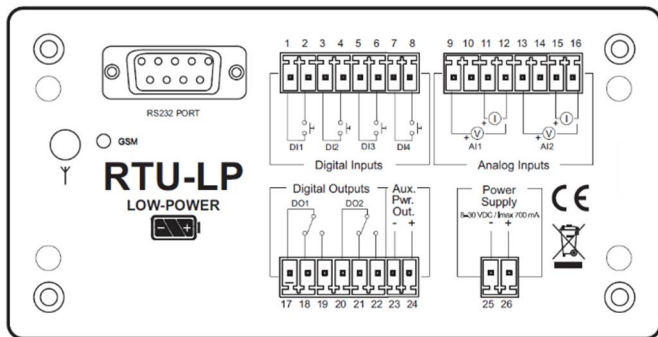
MODULE FRONT LAYOUT

RTU-LP-ST | RTU / Datalogger Low Power with embedded modem GSM/GPRS and I/O**ELECTRICAL CONNECTIONS****Power supply**

Batterie

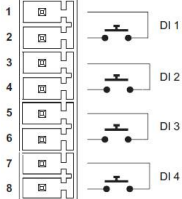

8..30 Vdc
Absorption 5 W max

Digital inputs

Rated voltage: 7 V
Rated current: 4 mA
Minimum current for ON status: 1.5 mA
Maximum cable resistance: 100 Ohm
Sampling frequency: 1 Hz
Each input has a 32 bit counter.
Insulation towards the other circuits: 500 Vdc

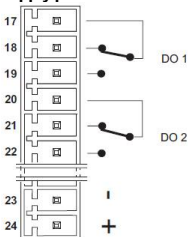
Digital outputs / Auxiliary supply port

Relay type: bistable
Relay capacity : 30 Vdc, 1 A Max, resistive load

Auxiliary output to supply the sensors
Maximum current 100 mA

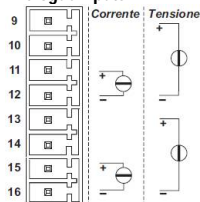
Analogue inputs

Measuring scales:

± 50 Vdc
 ± 20 Vdc
 ± 2 Vdc
 ± 20 mA

Insulation towards the other circuits: NO
Impedance of voltage input: 1 MOhm
Voltage drop with current input: 1.5 Vdc
protected by a self-resetting fuse

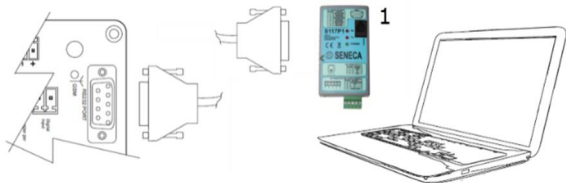
RTU-LP-ST | RTU / Datalogger Low Power with embedded modem GSM/GPRS and I/O**CONNECTION TO THE PC**

To connect to a PC, an RS232/USB (1) serial converter such as SENECA S117P1 is required. Once the converter is installed, just use the cables supplied:

To **configure the device**, the EASY RTU LP software must have been installed and the serial cable with the **CONFIG CABLE** label must be used.

To **update the firmware**, the EASY RTU LP software must have been installed and the serial cable with the **UPDATE CABLE** label must be used.

SOFTWARE AND ACCESSORIES

EASY RTU LP	Free software used to configure the device
BOX-RTU-IP65	Pre-wired IP65 case 290x140x108mm
BATT-S	Lithium battery pack 3 cells 10.8 V – 1.5 Ah
BATT-2S	Double lithium battery pack 3 cells 10.8 V – 25 Ah
A-GSM	External antenna (3m cable)
A-GSM-DIR-5M	Triband compact directive antenna (5m cable)
A-GSM-OMNIDIR	Triband omnidirectional antenna (5m cable)
A-GSM-OMNIDIR-10	Triband omnidirectional antenna (10m cable)
A-GSM-QUAD	4G omnidirectional external antenna (5m cable)
S117P1	RS232-TTL-RS485/USB serial converter
CS-DB9M-DB9F	Configuration serial cable (CONFIG CABLE)
CS-DB9M-DB9F-CR	Firmware update cable (UPDATE CABLE)
S-DIN	Support for DIN rail

CONTACTS

Technical support	support@seneca.it
Product information:	sales@seneca.it

For further information, refer to the online sheet and the USER MANUAL that can be downloaded free of charge from www.seneca.it/products/rtu-lp-st



**SCATTERGOOD
& JOHNSON LTD**
ELECTRICAL ENGINEERING & FLUID CONTROL DISTRIBUTORS

Est.1899

At Scattergood & Johnson Ltd, we pride ourselves on being a technical distributor to specialist industries.

Working with a range of quality product manufacturers across a number of specialist markets, we are not your average 'box shifter' - we are your technical and supply chain partner.

We fully support every product we sell - for free! Our internal team and external sales engineers can answer any product or application question, no matter the complexity.

Backing up this technical ability is a range of 50,000+ products available from stock for nationwide next day delivery (same day if required!), or you can collect what you need from any of our trade counters around the UK.

Select your specialist interest below to learn more about how we can help.



Online, In Branch and On the Road - Scattergood & Johnson Ltd, there when you need us.

www.scatts.co.uk