

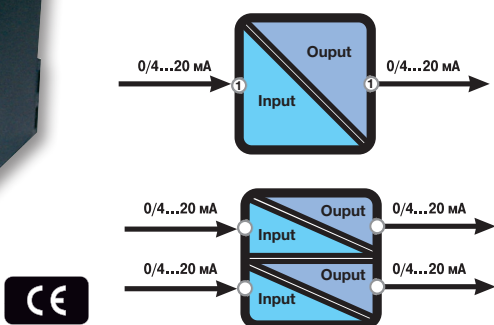

Z110

DC CURRENT ISOLATOR (SELF POWERED)



Z110 is a 4..20mA isolator powered through the input loop. It does not require any auxiliary power supply. Z110 is available in two different version: Z110S (single channel) or Z110D (double channel). A 2-way galvanic isolation between input // output circuits assures the integrity of your datas.

TECHNICAL SPECIFICATIONS

General Data

Power supply	From the 4-20 mA input loop
Power consumption	-
Isolation	1.500 Vac (2 way)
Power transducers	No
Accuracy	0,1%
Response time	100 ms
Status Indicators	Power supply, error, data transmission, data reception, input status
Setting	-
Mounting	35 mm DIN rail guide
Protection Degree	IP20
Operating Temperature	0..50°C
Dimension (W x H x D)	17.5 x 100 x 112 mm

Input

Channel Numbers	1 (Z110S), 2 (Z110D)
Current	4..20 mA

Output

Channel Numbers	1 (Z110S), 2 (Z110D)
Current	4..20 mA

Standard

Approval	CE
Norms	EN 50081-2; EN 55011; EN 50082-2; EN 61000-2-2/4; EN 50140/141; EN 61010-1

APPLICATION NOTE

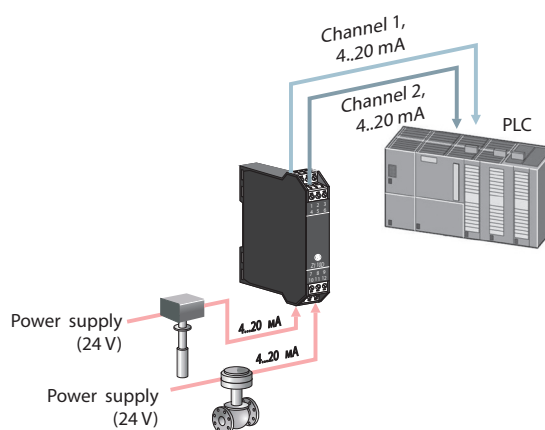

ORDER CODES

Code	Description
Z110S	DC current isolator - Self powered (single channel)
Z110D	DC current isolator - Self powered (double channel)

SIMILAR PRODUCTS

Z109S	Z109UI2	Z170REG
Dc current isolator	DC current / voltage to DC current/voltage isolator/ converter	DC current/voltage duplicator/isolator
pg. 81	pg. 80	pg. 84



**SCATTERGOOD
& JOHNSON LTD**
ELECTRICAL ENGINEERING & FLUID CONTROL DISTRIBUTORS

Est.1899

At Scattergood & Johnson Ltd, we pride ourselves on being a technical distributor to specialist industries.

Working with a range of quality product manufacturers across a number of specialist markets, we are not your average 'box shifter' - we are your technical and supply chain partner.

We fully support every product we sell - for free! Our internal team and external sales engineers can answer any product or application question, no matter the complexity.

Backing up this technical ability is a range of 50,000+ products available from stock for nationwide next day delivery (same day if required!), or you can collect what you need from any of our trade counters around the UK.

Select your specialist interest below to learn more about how we can help.



Online, In Branch and On the Road - Scattergood & Johnson Ltd, there when you need us.

www.scatts.co.uk