

# MACX MCR-EX-RTD-I - Temperature measuring transducer

1050222

<https://www.phoenixcontact.com/gb/products/1050222>

Please be informed that the data shown in this PDF document is generated from our online catalog. Please find the complete data in the user documentation. Our general terms of use for downloads are valid.



Ex i temperature transducer: converts signals from resistance temperature detectors installed in the Ex area and transmits a 0/4 - 20 mA signal to a load in the safe area. Freely programmable. 3-way isolation, SIL, screw connection, standard configuration.

## Your advantages

- Power supply possible via DIN rail connector
- Programming during operation with Ex measuring circuit connected and also voltage-free using IFS-USB-PROG-ADAPTER programming adapter
- Input for resistance thermometers and resistance-type sensors, [Ex ia] IIC
- Installation in zone 2, protection type "ec" (EN 60079-7) permitted
- 3-way electrical isolation
- Status indicator for supply voltage, cable, sensor, and module errors
- Configuration via software (FDT/DTM): sensor type, connection technology, measuring range, measuring unit, filter, alarm signal, and output range
- Output: 0 mA ... 20 mA or 4 mA ... 20 mA

# MACX MCR-EX-RTD-I - Temperature measuring transducer



1050222

<https://www.phoenixcontact.com/gb/products/1050222>

## Technical data

### Notes

#### Utilization restriction

EMC note	EMC: class A product, see manufacturer's declaration in the download area
----------	---

### Product properties

Product type	Temperature transmitter
Product family	MACX Analog
Application	Temperature
No. of channels	1
Type	Ex i signal conditioners with SIL functional safety
Configuration	Software

#### Insulation characteristics: GB Standard

Overvoltage category	II
Pollution degree	2

### Electrical properties

Alignment span	$\pm 5 \%$
Alignment zero	$\pm 5 \%$
Electrical isolation	3-way isolation
Electrical isolation between input and output	yes
Step response (0–99%)	1 s $\leq 1.7 \text{ s}$
Temperature coefficient, typical	0.01 %/K
Transmission error, typical	0.1 % (e.g. for Pt 100, 300 K span, 4 ... 20 mA)

#### Electrical isolation Input/output/power supply

Rated insulation voltage	300 V <sub>rms</sub>
Test voltage	2.5 kV AC (50 Hz, 60 s)
Insulation	Safe isolation in accordance with IEC/EN 61010-1

#### Electrical isolation Input/output

Electrical isolation	375 V (Peak value in accordance with IEC/EN 60079-11)
----------------------	---

#### Electrical isolation Input/power supply

Electrical isolation	375 V (Peak value in accordance with IEC/EN 60079-11)
----------------------	---

### Supply

Nominal supply voltage	24 V DC
Supply voltage range	19.2 V DC ... 30 V DC (24 V DC, -20 % ... +25 %)
Power dissipation	$\leq 0.76 \text{ W}$
Power consumption	$\leq 1 \text{ W}$

# MACX MCR-EX-RTD-I - Temperature measuring transducer



1050222

<https://www.phoenixcontact.com/gb/products/1050222>

## Input data

### Signal

Number of inputs	1
------------------	---

### Measurement

Description of the input	Intrinsically safe
Sensor types (RTD) that can be used	Pt, Ni, Cu sensors: 2, 3, 4-wire
Temperature measuring range	-200 °C ... 850 °C (Range depending on the sensor type)
Linear resistance measuring range	0 Ω ... 50 kΩ
Potentiometer resistance range	0 Ω ... 50 kΩ
Max. permissible overall conductor resistance	50 Ω (Per cable)
Sensor input current	10 μA ... 210 μA (Up to 2x 210 μA with 3-conductor technology)
Temperature measuring range	≥ 50 K

## Output data

### Signal: Current

Number of outputs	1
Configurable/programmable	Yes
Current output signal	0 mA ... 20 mA 4 mA ... 20 mA (SIL)
Max. current output signal	≥ 21 mA
Load/output load current output	≤ 600 Ω
Output ripple (current)	< 15 μA <sub>PP</sub> < 10 μA <sub>rms</sub>
Behavior in the event of a sensor error	As per NE 43 or can be freely defined

## Connection data

Connection method	Screw connection
Stripping length	7 mm
Screw thread	M3
Conductor cross section rigid	0.2 mm <sup>2</sup> ... 2.5 mm <sup>2</sup>
Conductor cross section flexible	0.2 mm <sup>2</sup> ... 2.5 mm <sup>2</sup>
Conductor cross section AWG	24 ... 14
Tightening torque	0.5 Nm ... 0.6 Nm

### Test socket

Max. diameter	2 mm
---------------	------

## Ex data

Ex installation (EPL)	Gc Div. 2
Ex i circuits (EPL)	Ga Da

# MACX MCR-EX-RTD-I - Temperature measuring transducer



1050222

<https://www.phoenixcontact.com/gb/products/1050222>

	Ma
	Div. 1
Safety data: Terminals: 4.1, 4.2, 5.1, 5.2	
Max. internal capacitance $C_i$	44 nF
Max. output voltage $U_o$	6 V
Max. output current $I_o$	16.6 mA (RTD in 4-conductor technology)
	13 mA (RTD in 3-conductor technology)
	7.1 mA (RTD in 2-conductor technology)
	16.6 mA (2x RTD in 2-conductor technology)
	13 mA (Potentiometer)
Max. output power $P_o$	25.2 mW (Linear)
Safety-related maximum voltage $U_m$	253 V AC
	125 V DC
	30 V DC (Zone 2: 3.1, 3.2)
IIA/I (simple circuit): Max. external inductivity $L_o$ / Max. external capacitance $C_o$	850 mH / 1000 $\mu$ F
IIB/IIIC (simple circuit): Max. external inductivity $L_o$ / Max. external capacitance $C_o$	460 mH / 1000 $\mu$ F
IIC (simple circuit): Max. external inductivity $L_o$ / Max. external capacitance $C_o$	100 mH / 40 $\mu$ F
IIB/IIA (mixed circuit): Max. external inductivity $L_o$ / Max. external capacitance $C_o$	100 mH / 950 nF, 50 mH / 950 nF, 5 mH / 950 nF, 1 mH / 950 nF
IIIC/I (mixed circuit): Max. external inductivity $L_o$ / Max. external capacitance $C_o$	100 mH / 950 nF, 50 mH / 950 nF, 5 mH / 950 nF, 1 mH / 950 nF
IIC (mixed circuit): Max. external inductivity $L_o$ / Max. external capacitance $C_o$	100 mH / 555 nF, 50 mH / 555 nF, 5 mH / 555 nF, 1 mH / 555 nF, 10 $\mu$ H / 555 nF

## Signaling

Status display	Green LED (supply voltage)
	Red LED, flashing 2.4 Hz (cable error, sensor error on input or output, ERR)
	Red LED, flashing 1.2 Hz (service operation, ERR)
	Red LED, permanently on (module error, ERR)

## Dimensions

Dimensional drawing	
Width	12.5 mm
Height	112.5 mm
Depth	113.7 mm

# MACX MCR-EX-RTD-I - Temperature measuring transducer



1050222

<https://www.phoenixcontact.com/gb/products/1050222>

Depth NS 35/7,5	114.5 mm (Snapped onto DIN rail NS 35/7,5 in accordance with EN 60715)
-----------------	--

## Material specifications

Color	gray (RAL 7042)
Flammability rating according to UL 94	V0 (Housing)
Housing material	PA 6.6-FR

## Environmental and real-life conditions

### Ambient conditions

Degree of protection	IP20
Ambient temperature (operation)	-40 °C ... 70 °C (Any mounting position)
Ambient temperature (storage/transport)	-40 °C ... 80 °C
Permissible humidity (operation)	5 % ... 95 % (non-condensing)

### Altitude range ( $\leq 2000$ m)

Altitude	$\leq 2000$ m (The technical data refers to altitudes $\leq 2000$ m above mean sea level. For altitudes $>2000$ m above mean sea level, refer to the data sheet.)
Ambient temperature (operation)	-40 °C ... 70 °C
Test voltage	2.5 kV
Rated insulation voltage	300 V <sub>rms</sub> (IEC/EN 60079-11) 375 V <sub>PP</sub> (IEC/EN 60079-11)

### Altitude range ( $\leq 3000$ m)

Height range	$> 2000$ m ... 3000 m
Ambient temperature (operation)	-40 °C ... 60 °C
Test voltage	2.25 kV
Safety-related maximum voltage U <sub>m</sub>	190 V AC 110 V DC
Rated insulation voltage	190 V <sub>rms</sub> (IEC/EN 60079-11)

### Altitude range ( $\leq 4000$ m)

Height range	$> 3000$ m ... 4000 m
Ambient temperature (operation)	-40 °C ... 55 °C
Test voltage	2 kV
Safety-related maximum voltage U <sub>m</sub>	60 V AC/DC
Rated insulation voltage	60 V <sub>rms</sub> (IEC/EN 60079-11)

### Altitude range ( $\leq 5000$ m)

Height range	$> 4000$ m ... 5000 m
Ambient temperature (operation)	-40 °C ... 49 °C
Test voltage	1.75 kV
Safety-related maximum voltage U <sub>m</sub>	60 V AC/DC
Rated insulation voltage	60 V <sub>rms</sub> (IEC/EN 60079-11)

## Approvals

# MACX MCR-EX-RTD-I - Temperature measuring transducer



1050222

<https://www.phoenixcontact.com/gb/products/1050222>

## CE

Certificate	CE-compliant
Note	and EN 61326

## ATEX

Identification	Ⓢ I (M1) [Ex ia Ma] I
	Ⓢ II (1) G [Ex ia Ga] IIC
	Ⓢ II (1) D [Ex ia Da] IIIC
	Ⓢ II 3(1) G Ex ec ic [ia Ga] IIC T4 Gc
Certificate	IBExU19ATEX1006 X

## UKCA Ex (UKEX)

Identification	Ⓢ I (M1) [Ex ia Ma] I
	Ⓢ II (1) G [Ex ia Ga] IIC
	Ⓢ II (1) D [Ex ia Da] IIIC
	Ⓢ II 3 (1) G Ex ec ic [ia Ga] IIC T4 Gc
Certificate	CML 22UKEX3531X

## IECEX

Identification	[Ex ia Ma] I
	[Ex ia Ga] IIC
	[Ex ia Da] IIIC
	Ex ec ic [ia Ga] IIC T4 Gc
Certificate	IECEX IBE 19.0001 X

## CCC / China-Ex

Identification	[Ex ia Ga] IIC
	[Ex iaD]
	Ex nA ic [ia Ga] IIC T4 Gc
Certificate	NEPSI GYJ20.1305X

## UL, USA/Canada

Identification	UL 61010 Listed
	Class I Div 2; IS for Class I, II, III Div 1
Certificate	Ⓢ.C.D.-No 83104549

## Shipbuilding approval

Certificate	DNV GL TAA00000AG
-------------	-------------------

## Safety Integrity Level (SIL, IEC 61508)

Identification	2
----------------	---

## INMETRO

Identification	[Ex ia Ma] I
	[Ex ia Ga] IIC
	[Ex ia Da] IIIC
	Ex ec ic [ia Ga] IIC T4 Gc

# MACX MCR-EX-RTD-I - Temperature measuring transducer



1050222

<https://www.phoenixcontact.com/gb/products/1050222>

Certificate	DNV 21.0064 X
-------------	---------------

## EAC Ex

Identification	Ex ia Ga IIC
	Ex ia Da IIIC
Certificate	RU C-DE.AB72.B.00093/19

## DNV GL data

Temperature	B
Humidity	B
Vibration	A
EMC	B
Enclosure	Required protection according to the Rules shall be provided upon installation on board

## EMC data

Noise immunity	EN 61000-6-2
Note	When being exposed to interference, there may be minimal deviations.
Electromagnetic compatibility	Conformance with EMC directive
Noise emission	EN 61000-6-4

## Electromagnetic HF field

Designation	Electromagnetic RF field
Standards/regulations	EN 61000-4-3
Typical deviation from the measuring range final value	1 %

## Fast transients (burst)

Designation	Fast transients (burst)
Standards/regulations	EN 61000-4-4
Typical deviation from the measuring range final value	1 %

## Conducted interference

Designation	Conducted interferences
Standards/regulations	EN 61000-4-6
Typical deviation from the measuring range final value	1 %

## Standards and regulations

Electrical isolation	3-way isolation
----------------------	-----------------

## GB Standard

Standards/regulations	GB 3626.20
	GB 3836.1
	GB 3836.4
	GB 3836.8
	GB 12476.1
	GB 12476.4

# MACX MCR-EX-RTD-I - Temperature measuring transducer



1050222

<https://www.phoenixcontact.com/gb/products/1050222>

## Mounting

Mounting type

DIN rail mounting

# MACX MCR-EX-RTD-I - Temperature measuring transducer

1050222

<https://www.phoenixcontact.com/gb/products/1050222>

## Drawings

Dimensional drawing

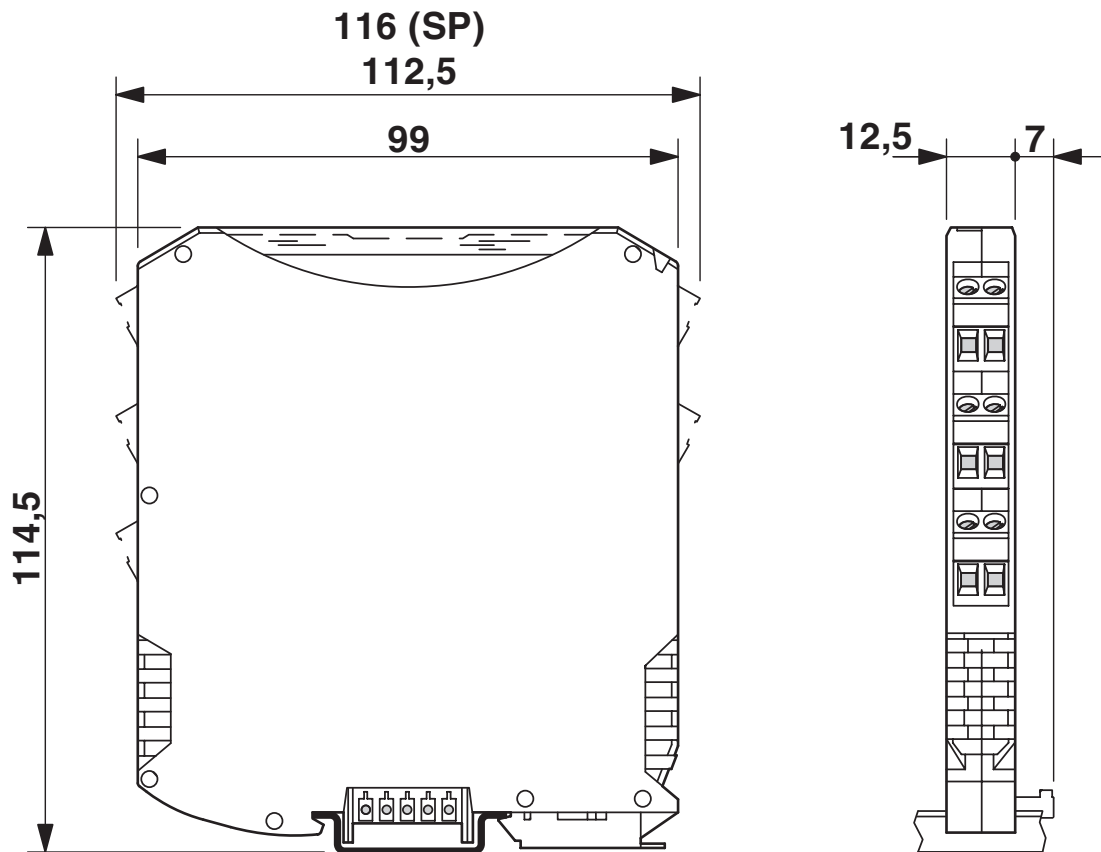

# MACX MCR-EX-RTD-I - Temperature measuring transducer

1050222

<https://www.phoenixcontact.com/gb/products/1050222>

Block diagram

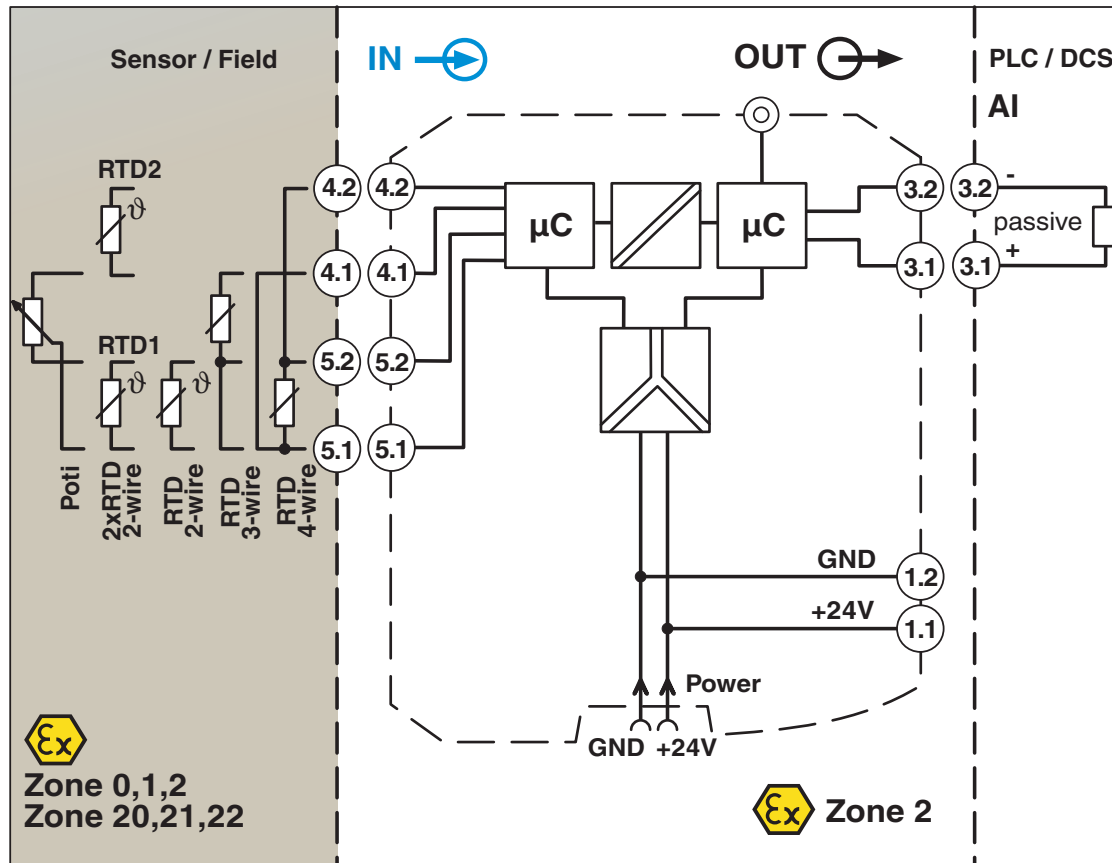

Phoenix Contact 2024 © - all rights reserved  
<https://www.phoenixcontact.com>

PHOENIX CONTACT Ltd  
 Halesfield 13, Telford  
 Shropshire, TF7 4PG  
 01952 681700  
[info@phoenixcontact.co.uk](mailto:info@phoenixcontact.co.uk)