



▶ PNOZ m EF EtherCAT FSoE

PILZ

THE SPIRIT OF SAFETY

Operating Manual-1006493-EN-01

- Configurable, safe small controllers PNOZmulti 2



This document is the original document.

Where unavoidable, for reasons of readability, the masculine form has been selected when formulating this document. We do assure you that all persons are regarded without discrimination and on an equal basis.

All rights to this documentation are reserved by Pilz GmbH & Co. KG. Copies may be made for the user's internal purposes. Suggestions and comments for improving this documentation will be gratefully received.

Pilz®, PIT®, PMI®, PNOZ®, Primo®, PSEN®, PSS®, PVIS®, SafetyBUS p®, SafetyEYE®, SafetyNET p®, the spirit of safety® are registered and protected trademarks of Pilz GmbH & Co. KG in some countries.



SD means Secure Digital

1	Introduction	5
1.1	Validity of documentation	5
1.2	Using the documentation	5
1.3	Terminology	5
1.4	Definition of symbols	5
1.5	Third-party manufacturer licence information	6
2	Overview	7
2.1	Scope of supply	7
2.2	Unit features	7
2.3	Front view	8
3	Safety	9
3.1	Intended use	9
3.2	Applicable documentation	9
3.3	System requirements	10
3.4	Safety regulations	10
3.4.1	Safety assessment	10
3.4.2	Use of qualified personnel	10
3.4.3	Warranty and liability	10
3.4.4	Disposal	11
3.4.5	For your safety	11
4	Security	12
4.1	Required security measures	12
5	Function description	13
5.1	Integrated protection mechanisms	13
5.2	EtherCAT and FSoE	13
5.3	Device description	14
5.4	Block diagram	16
6	Installation	17
6.1	General installation guidelines	17
6.2	Dimensions in mm	17
6.3	Connect the base unit and expansion modules	17
7	Commissioning	19
7.1	General wiring guidelines	19
7.2	Connecting the supply voltage	19
7.3	Interface assignment	20
7.4	Download modified project to the PNOZmulti safety system	20
8	Operation	21
8.1	LED indicators	21

9	Maintenance and testing	23
10	Technical details	24
10.1	Safety characteristic data	26
11	Order reference	27
11.1	Product	27
11.2	Accessories	27
12	EC declaration of conformity	28
13	UKCA-Declaration of Conformity	29

1 Introduction

1.1 Validity of documentation

This documentation is valid for the product PNOZ m EF EtherCAT FSoE from Version HW:01, FW:01.00.

This operating manual explains the function and operation, describes the installation and provides guidelines on how to connect the product.

1.2 Using the documentation

This document is intended for instruction. Only install and commission the product if you have read and understood this document. The document should be retained for future reference.

1.3 Terminology

EtherCAT® and Safety over EtherCAT® are registered trademarks and patented technology, licensed by Beckhoff Automation GmbH, Germany.

► Bus system terminology

The description contains various technical terms, which are established and defined by the bus system's user organisation. These include the terms "Master" and "Slave".

1.4 Definition of symbols

Information that is particularly important is identified as follows:



DANGER!

This warning must be heeded! It warns of a hazardous situation that poses an immediate threat of serious injury and death and indicates preventive measures that can be taken.



WARNING!

This warning must be heeded! It warns of a hazardous situation that could lead to serious injury and death and indicates preventive measures that can be taken.



CAUTION!

This refers to a hazard that can lead to a less serious or minor injury plus material damage, and also provides information on preventive measures that can be taken.



NOTICE

This describes a situation in which the product or devices could be damaged and also provides information on preventive measures that can be taken. It also highlights areas within the text that are of particular importance.



INFORMATION

This gives advice on applications and provides information on special features.

1.5 Third-party manufacturer licence information

This product includes Open Source software with various licenses.

Further information is available in the document "Third-party manufacturer licence information PNOZ m EF EtherCAT FSoE" (document number 1006669) at www.pilz.com.

2 Overview

2.1 Scope of supply

- ▶ Expansion module PNOZ m EF EtherCAT FSoE
- ▶ Jumper

2.2 Unit features

Application of the product PNOZ m EF EtherCAT FSoE:

Expansion module for connection to a base unit from the PNOZmulti 2 system.

The product has the following features:

- ▶ Configurable in the PNOZmulti Configurator
- ▶ Operation as FSoE Master: max. 60 connections
- ▶ Operation as FSoE Slave: max. 4 connections
- ▶ Max. 16 Byte input and 16 Byte output data per connection
- ▶ Up to 512 Bit failsafe input process data and 512 Bit failsafe output process data can be transferred per FSoE Master
- ▶ In the PNOZmulti Configurator, 128 virtual inputs and outputs on the PNOZmulti can be defined for communication with EtherCAT
- ▶ Network protocols: EtherCAT, FSoE
- ▶ Status indicators for communication with EtherCAT and FSoE and for errors
- ▶ Max. 1 PNOZ m EF EtherCAT FSoE can be connected to the base unit
- ▶ Plug-in connection terminals:
Either spring-loaded terminal or screw terminal available as an accessory (see Order references for accessories).
- ▶ Please refer to the document "PNOZmulti System Expansion" for details of the base units PNOZmulti 2 that can be connected.

2.3 Front view

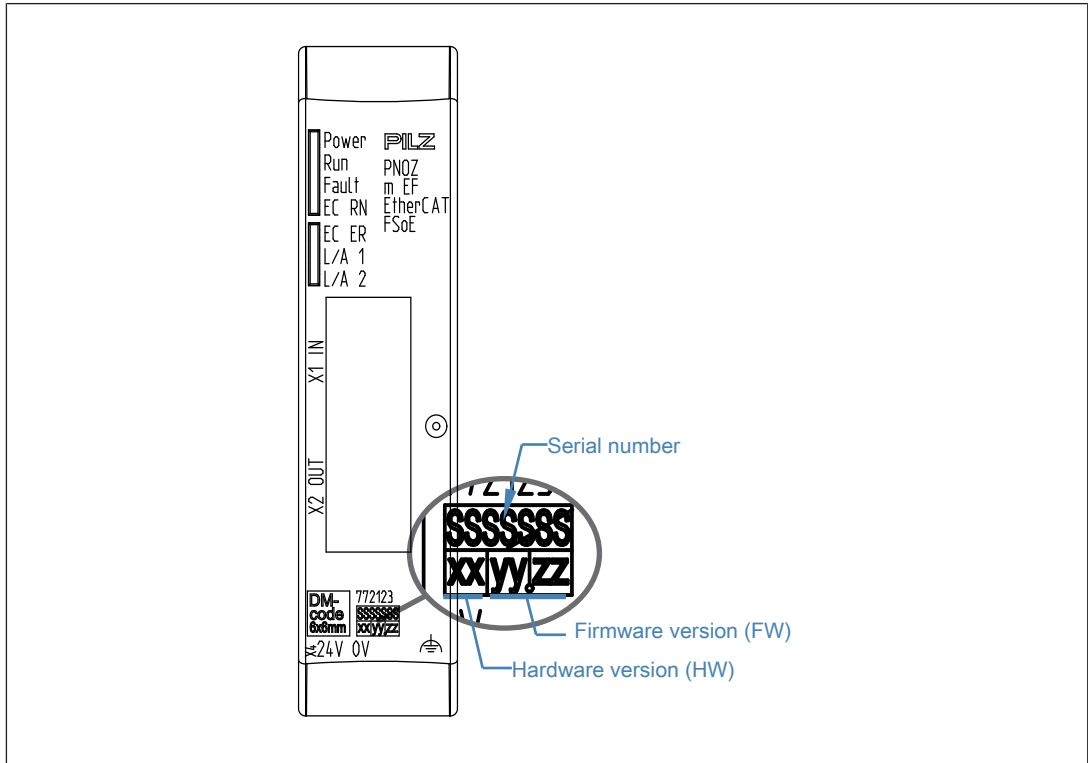

Legend:

- X1: EtherCAT IN
RJ45 input interface to establish the EtherCAT connection
- X2: EtherCAT OUT
RJ45 output interface to establish the EtherCAT connection
- X4: 0 V, 24 V
- Supply connections
- Functional earth
- LEDs: Power
- Run
- Fault
- EC RN (EtherCAT Run)
- EC ER (EtherCAT Error)
- L/A 1 (Link Activity 1)
- L/A 2 (Link Activity 2)

EtherCAT® and Safety over EtherCAT® are registered trademarks and patented technology, licensed by Beckhoff Automation GmbH, Germany.

3 Safety

3.1 Intended use

The expansion module PNOZ m EF EtherCAT FSoE acts as Master and/or Slave for communication with FailSafe over EtherCAT and as Slave for communication via EtherCAT.

FailSafe over EtherCAT (FSoE) is used for safe data exchange between FSoE subscribers. Communication is via the EtherCAT network.

The expansion module may only be connected to a base unit from the configurable system PNOZmulti 2 (please refer to the document "PNOZmulti System Expansion" for details of the base units that can be connected).

The configurable small control systems PNOZmulti are used for the safety-related interruption of safety circuits and are designed for use in:

- ▶ E-STOP equipment
- ▶ Safety circuits in accordance with VDE 0113 Part 1 and EN 60204-1

Improper use

The following is deemed improper use in particular:

- ▶ Any component, technical or electrical modification to the product,
- ▶ Use of the product outside the areas described in this operating manual,
- ▶ Use of the product outside the technical details (see chapter entitled [Technical Details](#) [ 24]).



NOTICE

EMC-compliant electrical installation

The product is designed for use in an industrial environment. The product may cause interference if installed in other environments. If installed in other environments, measures should be taken to comply with the applicable standards and directives for the respective installation site with regard to interference.

3.2 Applicable documentation

This document includes only part of the information required for the use of the device. To understand and correctly use the product you must read further documents.

Please read the following documents:

- ▶ "PNOZmulti Safety Manual"
- ▶ "PNOZmulti Installation Manual"
- ▶ System Description FSoE
- ▶ The advanced functions of the device are described in the online help for the PNOZmulti Configurator, in the document "PNOZmulti Communication Interfaces" and in the document "PNOZmulti Special Applications". Only use these functions once you have read and understood the documentation.

- ▶ The connectable PNOZmulti base units, the max. number of connectable modules and the system reaction times can be taken from the document "PNOZmulti System Expansion".

3.3 System requirements

Please refer to the "Product Modifications PNOZmulti" document in the "Version overview" section for details of which versions of the base unit and PNOZmulti Configurator can be used for this product.

3.4 Safety regulations

3.4.1 Safety assessment

Before using a device, a safety assessment in accordance with the Machinery Directive is required.

The product as an individual component fulfils the functional safety requirements in accordance with EN ISO 13849 and EN IEC 62061. However, this does not guarantee the functional safety of the overall plant/machine. To achieve the relevant safety level of the overall plant/machine's required safety functions, each safety function needs to be considered separately.

3.4.2 Use of qualified personnel

The products may only be assembled, installed, programmed, commissioned, operated, maintained and decommissioned by persons who are competent to do so.

A competent person is a qualified and knowledgeable person who, because of their training, experience and current professional activity, has the specialist knowledge required. In order to inspect, assess and handle products, devices, systems, plant and machinery, this person must be familiar with the state of the art and the applicable national, European and international laws, directives and standards.

It is the company's responsibility only to employ personnel who

- ▶ Are familiar with the basic regulations concerning health and safety / accident prevention,
- ▶ Have read and understood the information provided in the section entitled Safety
- ▶ Have a good knowledge of the generic and specialist standards applicable to the specific application.

3.4.3 Warranty and liability

All claims to warranty and liability will be rendered invalid if

- ▶ The product was used contrary to the purpose for which it is intended,
- ▶ Damage can be attributed to not having followed the guidelines in the manual,
- ▶ Operating personnel are not suitably qualified,
- ▶ Any type of modification has been made (e.g. exchanging components on the PCB boards, soldering work etc.).

3.4.4 Disposal

- ▶ In safety-related applications, please comply with the mission time T_M in the safety-related characteristic data.
- ▶ When decommissioning, please comply with local regulations regarding the disposal of electronic devices (e.g. Electrical and Electronic Equipment Act).

3.4.5 For your safety

The unit meets all the necessary conditions for safe operation. However, you should always ensure that the following safety requirements are met:

- ▶ This operating manual only describes the basic functions of the unit. The expanded functions are described in the PNOZmulti Configurator's online help. Only use these functions once you have read and understood the documentations.
- ▶ Do not open the housing or make any unauthorised modifications.
- ▶ Please make sure you shut down the supply voltage when performing maintenance work (e.g. exchanging contactors).

4 Security

To secure plants, systems, machines and networks against cyberthreats it is necessary to implement (and continuously maintain) an overall industrial security concept that is state of the art.

Perform a risk assessment in accordance with VDI/VDE 2182 or IEC 62443-3-2 and plan the security measures with care. If necessary, seek advice from Pilz Customer Support.

4.1 Required security measures

- ▶ The product is not protected against physical manipulation. Use appropriate measures to ensure that there is no physical access by unauthorised persons. You should also use security seals so that you can detect any manipulation of the product or interfaces. Installation inside a lockable control cabinet is recommended as a minimum measure.
- ▶ Make sure that the product is in a closed, secured EtherCAT network.

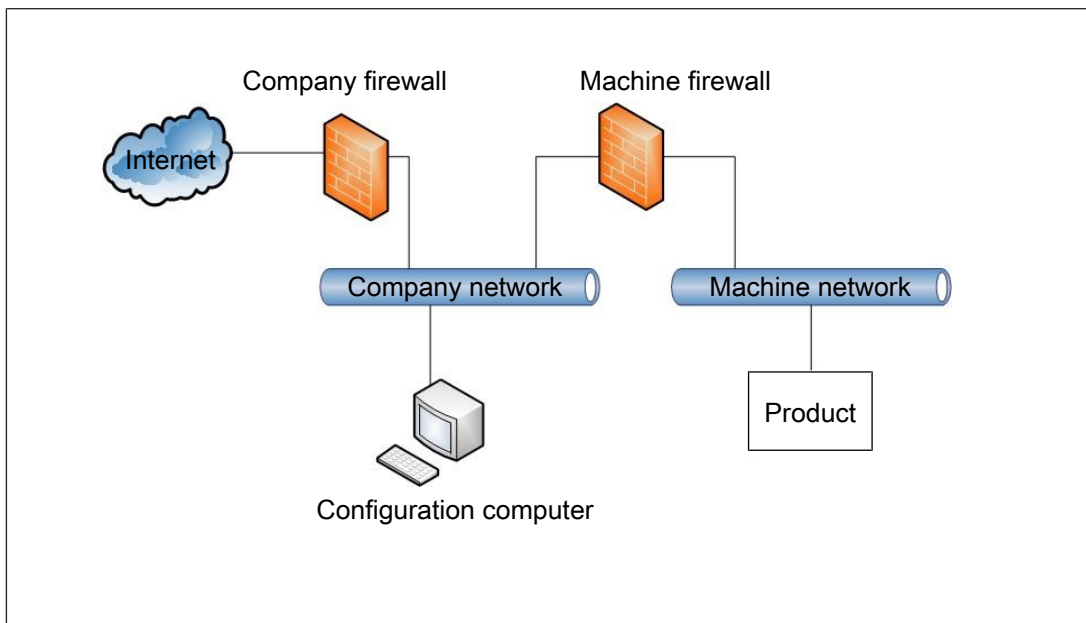

Fig.: Example network topology

- ▶ Note the network data for risk analysis and the security measures.

5 Function description

5.1 Integrated protection mechanisms

The relay meets the following safety requirements:

- ▶ The circuit is redundant with built-in self-monitoring.
- ▶ The safety device remains effective in the case of a component failure.

5.2 EtherCAT and FSoE

The basic communication functions with EtherCAT conform to the System Description from the EtherCAT User Group.

The EtherCAT network consists of an EtherCAT Master and one or several slaves. The EtherCAT telegram includes standard data, and also safe data (FSoE data) can be transferred via this.

The module PNOZ m EF EtherCAT FSoE can be used as FSoE Master and as FSoE Slave. Also, it is an EtherCAT Slave subscriber.

The module PNOZ m EF EtherCAT FSoE can transfer safe data via FSoE and send and receive non-safety-related data via EtherCAT.

The FSoE log is standardised in the standard IEC 61784-3 international and marks a safe communication system to transfer safe process data between FSoE modules. FS is an open technology, supported by the EtherCAT Technology Group (ETG).

A prerequisite for FSoE communication via the EtherCAT network is a functioning EtherCAT network with an EtherCAT Master.

Within the Standard EtherCAT telegram [1] FSoE data are transported in a safe data container (FSoE Frame) [2].

The FSoE Master initiates communication with a request telegram. The FSoE Master receives the FSoE data from the FSoE Slaves and evaluates them safety-related. The data are available in the PNOZmulti module program PNOZ m EF EtherCAT FSoE.

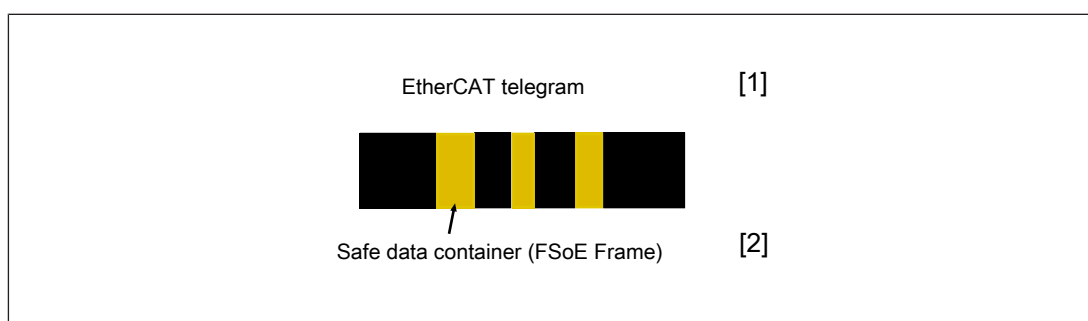

The FSoE cycle time of the module PNOZ m EF EtherCAT FSoE is a max. of 10 ms.

The FSoE connections are monitored using a watchdog to be able to detect interruptions.

5.3 Device description

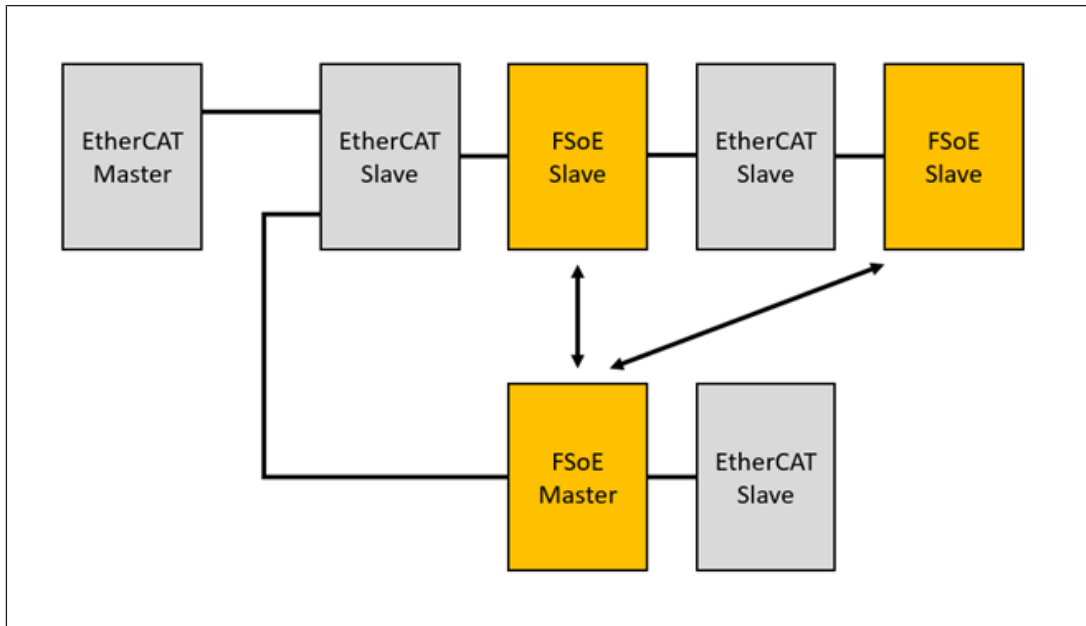

An EtherCAT Network requires an EtherCAT Master, it communicates with the EtherCAT Slaves. When failsafe data is to be exchanged via FSoE, an FSoE Master (such as the module PNOZ m EF EtherCAT FSoE) and at least one FSoE Slave are required. The FSoE Master is also an EtherCAT Slave.

The expansion module PNOZ m EF EtherCAT FSoE can be configured as FSoE Master or FSoE Slave.

All the data from the EtherCAT Slaves (also the FSoE subscribers) is transferred via the EtherCAT Master.

Connections to the FSoE Slaves are created in the PNOZmulti Configurator. The corresponding data must be copied or mapped in EtherCAT Master so that the corresponding data from the FSoE Slaves is available to the FSoE Master and vice versa.

The PNOZmulti can act as Master or Slave, or also simultaneously as Master and Slave.

The configuration is described in the PNOZmulti Configurator's online help.

The base unit and the expansion module PNOZ m EF EtherCAT FSoE are connected via a jumper. After the supply voltage is switched on or the PNOZmulti control system is reset, the expansion module PNOZ m EF EtherCAT FSoE is configured and started automatically.



NOTICE

Please note:

When the connection is lost, the system restarts automatically. There is no restart interlock.

The connection to EtherCAT is established via the two RJ45 sockets.

LEDs indicate the status of the expansion module on the EtherCAT FSoE.

Failsafe over EtherCAT

- ▶ The cycle time of the module PNOZ m EF EtherCAT FSoE is a max. 10 ms.
- ▶ The watchdog timeout can be set to a value between 20 ms ... 65 534 ms.
- ▶ The FSoE Master/Slave function and the EtherCAT Slave function are available in parallel operation.
- ▶ The EtherCAT Slave function can be operated without the FSoE Master/Slave function.
- ▶ FSoE Master properties
 - The FSoE Master function is implemented by the "Modular Device Profile" ETG 5001 - 6900.
 - A max. of 60 connections can be created to FSoE Slave devices.
 - Only "Bool" data types from the FSoE Master function can be processed in the application.
 - The maximum number of application parameters for all the configured FSoE Slave connections is 6000 Bytes.
- ▶ FSoE Slave properties
 - The FSoE Slave function is implemented by the "Modular Device Profile" ETG 5001 - 195.
 - The FSoE Slave function does not contain any safe device parameters.
 - A max. of 4 connections to FSoE Master devices can be established.
 - Only the "Bool" data type from the FSoE Slave function can be processed in the application.
- ▶ In total (Master and Slave), a maximum of 64 connections can be established to other FSoE subscribers.
- ▶ When using SRA parameters, these must always be transferred in full via the FSoE protocol when the FSoE connection is started up. Use of a CRC via the SRA parameters is not supported.
- ▶ A maximum of 512 Bit failsafe input process data can be transferred.
- ▶ A maximum of 512 Bit failsafe output process data can be transferred.
- ▶ A minimum of 8 Bit failsafe input process data / 8 Bit failsafe output process data can be transferred per FSoE connection.
- ▶ A maximum of 128 Bit input and 128 Bit output payload data can be used per FSoE connection.

EtherCAT

- ▶ A total of up to 128 Bit inputs can be configured for standard applications in the module program and in the user program of the PNOZmulti Configurator.
- ▶ The 128 Bit outputs of the module program and user program can be set by both the module program and the main program on the base unit. If the assignment is duplicated, these will be OR-linked in the PNOZ m EF EtherCAT FSoE.
- ▶ The ESI file (EtherCAT Information File) has the name: PNOZ_m_EF_EtherCAT_FSoE.xml

5.4 Block diagram

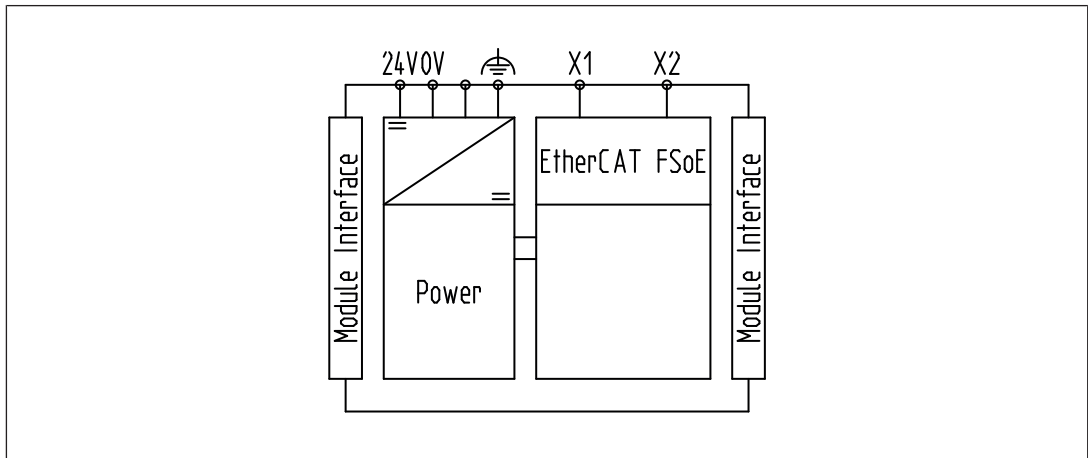

6 Installation

6.1 General installation guidelines

- ▶ The unit should be installed in a control cabinet with a protection type of at least IP54.
- ▶ Install the system vertically on to a horizontal mounting rail. The venting slots must face upward and downward. Other mounting positions could damage the safety system.
- ▶ Use the locking elements on the rear of the unit to attach it to a mounting rail.
- ▶ In environments exposed to heavy vibration, the unit should be secured using a fixing element (e.g. retaining bracket or end angle).
- ▶ Open the locking slide before lifting the unit from the mounting rail.
- ▶ To comply with EMC requirements, the mounting rail must have a low impedance connection to the control cabinet housing.
- ▶ The ambient temperature in the control cabinet must not exceed the figure stated in the technical details. otherwise air conditioning may be required.



NOTICE

Damage due to electrostatic discharge!

Electrostatic discharge can damage components. Ensure against discharge before touching the product, e.g. by touching an earthed, conductive surface or by wearing an earthed armband.

6.2 Dimensions in mm

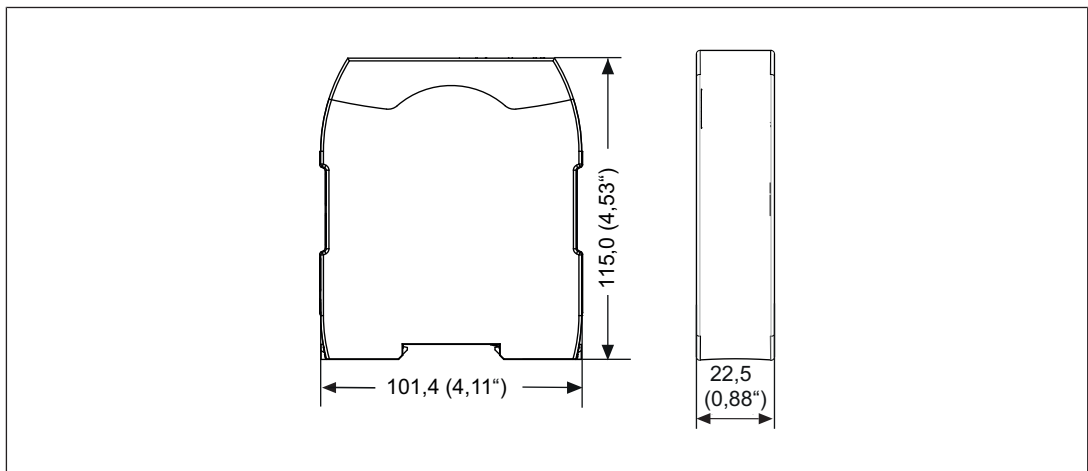

6.3 Connect the base unit and expansion modules

Connect the base unit and the expansion module as described in the operating instructions for the base units.

- ▶ Connect the black/yellow terminator to the expansion module.
- ▶ Install the expansion module in the position in which it is configured in the PNOZmulti Configurator.

The position of the expansion modules is defined in the PNOZmulti Configurator. The expansion modules are connected to the left or right of the base unit, depending on the type. Please refer to the document "PNOZmulti System Expansion" for details of the number of modules that can be connected to the base unit and the module types.



CAUTION!

Please note:

Only connect the expansion modules on the slot stated in the document "System expansion", otherwise the expansion module may be destroyed as a result.

7 Commissioning

7.1 General wiring guidelines

The wiring is defined in the circuit diagram of the PNOZmulti Configurator.

It is possible to define which inputs and outputs on the safety system will communicate with EtherCAT.

Note:

- ▶ Information given in the "Technical details" must be followed.
- ▶ Use copper wiring with a temperature stability of 75 °C.
- ▶ The power supply must meet the regulations for extra low voltages with protective separation (SELV/PELV).
- ▶ External measures must be used to connect the terminal  to the functional earth, when the mounting rail is **not** connected to the functional earth.

Please note the following when connecting to EtherCAT:

- ▶ The following minimum requirements of the connection cable and connector must be met:
 - Only use standard industrial Ethernet cable and connectors.
 - Only use double-shielded twisted pair cable and shielded RJ45 connectors (industrial connectors).
 - 100BaseTX cable in accordance with the Ethernet standard (min. category 5)
- ▶ Ring topology is used to implement cable redundancy. To do this, at least 2 Ethernet ports must be available on the EtherCAT Master.
- ▶ Measures to protect against interference:

Ensure the requirements for the industrial use of EtherCAT are met, as stated in the Installation Manual published by the user organisation.



CAUTION!

Only connect and disconnect the expansion module when the supply voltage is switched off.

7.2 Connecting the supply voltage

Connect the supply voltage to the fieldbus module:

- ▶ **24 V** terminal: + 24 VDC
- ▶ **0 V** terminal: 0 V
- ▶ Protect the supply voltage as follows:
 - Circuit breaker, characteristic C - 6 A
 - or
 - Blow-out fuse, slow, 6A

7.3 Interface assignment

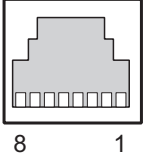
RJ45 socket 8-pin	PIN	Standard
	1	TD+ (Transmit+)
	2	TD- (Transmit-)
	3	RD+ (Receive+)
	4	n.c.
	5	n.c.
	6	RD- (Receive-)
	7	n.c.
	8	n.c.

n.c.: Not connected

7.4 Download modified project to the PNOZmulti safety system

As soon as an additional expansion module has been connected to the system, the project must be amended in the PNOZmulti Configurator and downloaded back into the base unit. Proceed as described in the operating manual for the base unit.



NOTICE

For the commissioning and after every user program change, you must check whether the safety devices are functioning correctly.

8 Operation







When the supply voltage is switched on, the PNOZmulti copies the configuration from the removeable data medium.













The expansion module PNOZ m EF EtherCAT FSoE is configured and started automatically. The LEDs "RUN", "Fault", "EC RN" and "EC ER" indicate the status of the PNOZ m EF EtherCAT FSoE on EtherCAT.

After the project has been downloaded and the base unit restarted, the EtherCAT/FSoE configuration is transferred to the module. All EtherCAT connections are briefly disconnected in the process. All the EtherCAT devices that follow are shut down. Both Link/Traffic LEDs go off for a few seconds.

8.1 LED indicators

Legend

-  LED on
-  LED flashes
-  LED flashes quickly
-  LED flashes 1x quickly
-  LED flashes 2x quickly
-  LED off

LEDs							Description
Power	Run	Fault	EC RN	EC ER	L/A 1	L/A 2	
							Supply voltage is present.
							Supply voltage is not present.
							The module is in start-up.
							At least one FSoE connection is not in "DATA" state.
							All FSoE connections are in "DATA" state.
							External error. Can be read in the error stack in the PNOZmulti Configurator.

LEDs							Description
Power	Ruin	Fault	EC RN	EC ER	L/A 1	L/A 2	
							Input/output error: <ul style="list-style-type: none"> ▶ Partially operated ▶ Operating mode selector switch ▶ Feedback loop signal is missing
							Internal module error. Contact Pilz.
							EtherCAT is in "OPERATIONAL" state.
							EtherCAT is in "PRE-OPERATIONAL" state.
							EtherCAT is in "SAFE-OPERATIONAL" state.
							EtherCAT is in "INITIALISATION" state.
							EtherCAT application error
							Invalid EtherCAT configuration
							Watchdog timeout
							Local error in the EtherCAT connection
							Bus connection available at X1.
							Data traffic available at X1.
							No bus connection available at X1.
							Bus connection available at X2.
							Data traffic present at X2.
							No bus connection available at X2.



NOTICE

For the error EC ER (EtherCAT error), please also refer to the EtherCAT Master diagnostics.

9 Maintenance and testing

It is not necessary to perform maintenance work on the product in normal operation. Please return any faulty products to Pilz.

Please note when exchanging the device:

The configuration is saved on the base unit. When exchanging the module PNOZ m EF EtherCAT FSoE, the project in the base unit must be reset or downloaded to the base unit again from the PNOZmulti Configurator.

10 Technical details

General	
Certifications	CE, EAC, TÜV, UKCA
Application range	Failsafe
Module's device code	00A0h
Electrical data	
Supply voltage	
for	Module supply
Voltage	24 V
Kind	DC
Voltage tolerance	-20 %/+25 %
Max. continuous current that the external power supply must provide	120 mA
Output of external power supply (DC)	3 W
External unit fuse protection F1	6 A, circuit breaker 24 V DC, characteristic B
Potential isolation	Yes
Supply voltage	
for	Module supply
internal	Via base unit
Voltage	3,3 V
Kind	DC
Current consumption	60 mA
Power consumption	0,2 W
Max. power dissipation of module	3,5 W
Status indicator	LED
Fieldbus interface	
Fieldbus interface	EtherCAT, FSoE
Device type	Device
Connection	2 x RJ45
Galvanic isolation	Yes
Environmental data	
Ambient temperature	
in accordance with the standard	EN 60068-2-14
Temperature range	0 - 60 °C
Forced convection in control cabinet off	55 °C
Storage temperature	
in accordance with the standard	EN 60068-2-1/-2
Temperature range	-25 - 70 °C
Climatic suitability	
in accordance with the standard	EN 60068-2-30, EN 60068-2-78
Humidity	93 % r. h. at 40 °C
Condensation during operation	Not permitted
Max. operating height above SL	2000 m
EMC	EN 61131-2

Environmental data

Vibration

in accordance with the standard	EN 60068-2-6
Frequency	5 - 150 Hz
Acceleration	1g

Shock stress

in accordance with the standard	EN 60068-2-27
Acceleration	15g
Duration	11 ms

Airgap creepage

in accordance with the standard	EN 61131-2
Overvoltage category	II
Pollution degree	2

Protection type

in accordance with the standard	EN 60529
Housing	IP20
Terminals	IP20
Mounting area (e.g. control cabinet)	IP54

Potential isolation

Potential isolation between	Fieldbus and module voltage
Type of potential isolation	Functional insulation
Rated insulation voltage	30 V
Rated surge voltage	500 V

Mechanical data

Mounting position	horizontally on mounting rail
DIN rail	
Top hat rail	35 x 15 EN/IEC 60715, 35 x 7,5 EN/IEC 60715
Recess width	27 mm
Material	
Bottom	PC
Front	PC
Top	PC
Connection type	Spring-loaded terminal, screw terminal
Mounting type	plug-in
Conductor cross section with screw terminals	
1 core flexible	0,25 - 2,5 mm², 24 - 12 AWG
2 core with the same cross section, flexible without crimp connectors or with TWIN crimp connectors	0,2 - 1,5 mm², 24 - 16 AWG
Torque setting with screw terminals	0,5 Nm
Conductor cross section with spring-loaded terminals:	
Flexible with/without crimp connector	0,2 - 2,5 mm², 24 - 12 AWG
Spring-loaded terminals: Terminal points per connection	2
Stripping length with spring-loaded terminals	9 mm

Mechanical data

Dimensions

Height	101,4 mm
Width	22,5 mm
Depth	115 mm

Weight	115 g
--------	--------------

Where standards are undated, the 2023-02 latest editions shall apply.

10.1 Safety characteristic data



NOTICE

You must comply with the safety characteristic data in order to achieve the required safety level for your plant/machine.

Operating mode	EN ISO 13849-1: 2015	EN ISO 13849-1: 2015	EN IEC 62061 SIL CL/max.	EN IEC 62061 61508	EN/IEC 61511 61508	EN/IEC 61511 61508	EN ISO 13849-1: 2015
	PL	Category	SIL	PFH _D [1/h]	SIL	PFD	T _M [year]
2-channel	PL e	Cat. 4	SIL 3	1,56E-09	SIL 3	5,67E-05	20

Explanatory notes for the safety-related characteristic data:

- ▶ T_M is the maximum mission time in accordance with EN ISO 13849-1. The value also applies as the retest interval in accordance with EN/IEC 61508-6 and EN/IEC 61511 and as the proof test interval and mission time in accordance with EN IEC 62061

All the units used within a safety function must be considered when calculating the safety characteristic data.



INFORMATION

A safety function's SIL/PL values are **not** identical to the SIL/PL values of the units that are used and may differ from these.

11 Order reference

11.1 Product

Product type	Features	Order no.
PNOZ m EF EtherCAT FSoE	Configurable safe small controllers PNOZmulti 2, FSoE Master	772123

11.2 Accessories

Terminator, jumper

Product type	Features	Order no.
PNOZ mm0.xp connector left	Jumper yellow/black to connect the modules, 10 pieces	779260

Connection terminals, plug-in connectors

Product type	Features	Order no.
Spring terminals PNOZ mmcxp 1 pc.	Spring-loaded terminals, 1 piece	783542
Spring terminals PNOZ mmcxp 10 pcs.	Spring-loaded terminals, 10 pieces	783543
Screw terminals PNOZ mmcxp 1 pc.	Screw terminals, 1 piece	793542
Screw terminals PNOZ mmcxp 10 pcs.	Screw terminals, 10 pieces	793543
RJ45 Connector	RJ45 plug-in connector, straight, IP20, 8-pin, Cat6a, IDC connection, AWG 22, cable diameter: 5.5 - 8.5 mm	380401

12 **EC declaration of conformity**

This product/these products meet the requirements of the directive 2006/42/EC on machinery of the European Parliament and of the Council. The complete EC Declaration of Conformity is available on the Internet at www.pilz.com/downloads.

Representative: Pilz GmbH & Co. KG, Felix-Wankel-Str. 2, 73760 Ostfildern, Germany

13 UKCA-Declaration of Conformity

This product(s) complies with following UK legislation: Supply of Machinery (Safety) Regulation 2008.

The complete UKCA Declaration of Conformity is available on the Internet at www.pilz.com/downloads.

Representative: Pilz Automation Technology, Pilz House, Little Colliers Field, Corby, Northamptonshire, NN18 8TJ United Kingdom, eMail: mail@pilz.co.uk

Support

Technical support is available from Pilz round the clock.

Americas

Brazil

+55 11 97569-2804

Canada

+1 888 315 7459

Mexico

+52 55 5572 1300

USA (toll-free)

+1 877-PILZUSA (745-9872)

Asia

China

+86 400-088-3566

Japan

+81 45 471-2281

South Korea

+82 31 778 3300

Australia and Oceania

Australia

+61 3 95600621

New Zealand

+64 9 6345350

Europe

Austria

+43 1 7986263-444

Belgium, Luxembourg

+32 9 3217570

France

+33 3 88104003

Germany

+49 711 3409-444

Ireland

+353 21 4804983

Italy, Malta

+39 0362 1826711

Scandinavia

+45 74436332

Spain

+34 938497433

Switzerland

+41 62 88979-32

The Netherlands

+31 347 320477

Türkiye

+90 216 5775552

United Kingdom

+44 1536 462203

You can reach our international hotline on:

+49 711 3409-222

support@pilz.com

Pilz develops environmentally-friendly products using ecological materials and energy-saving technologies. Offices and production facilities are ecologically designed, environmentally-aware and energy-saving. So Pilz offers sustainability, plus the security of using energy-efficient products and environmentally-friendly solutions.



We are represented internationally. Please refer to our homepage www.pilz.com for further details or contact our headquarters.

Headquarters: Pilz GmbH & Co. KG, Felix-Wankel-Straße 2, 73760 Ostfildern, Germany
Telephone: +49 711 3409-0, E-Mail: info@pilz.com, Internet: www.pilz.com

PILZ
THE SPIRIT OF SAFETY

CECE[®], CHRE[®], CMSE[®], INDUSTRIAL P[®], Leansafe[®], Myzel[®], PAS4000[®], PASscal[®], PASconfig[®], Pilz[®], PIT[®], PMSprimo[®], PMSprotego[®], PMCiendo[®], PMD[®], PMI[®], PNOZ[®], Primo[®], PSEN[®], PSS[®], PVIS[®], SafetyBUS p[®], SafetyNET p[®], THE SPIRIT OF SAFETY[®] are registered and protected trademarks of Pilz GmbH & Co. KG in some countries. We would point out that product features may vary from the details stated in this document, depending on the status at the time of publication and the scope of the equipment. We accept no responsibility for the validity, accuracy and entirety of the text and graphics presented in this information. Please contact our Technical Support if you have any questions.

1006493-EN-01, Printed in Germany
© Pilz GmbH & Co. KG, 2019