



Surface mount enclosures IP65 (4X) for SM1P SM1Z  
Surface mount enclosures IP65 (4X) for SM1P SM1P...

Product designation

Product type designation

Description

Accessories for

**Mechanical features**

Weight

g 315

**Operations**

Mechanical life

cycles 100000

**Ambient conditions**

Temperature

Operating temperature

min	°C	-25
max	°C	+60

Storage temperature

min	°C	-50
max	°C	+80

IEC degree of protection

IP65

UL degree of protection

4X

**Dimensions [mm (in)]**

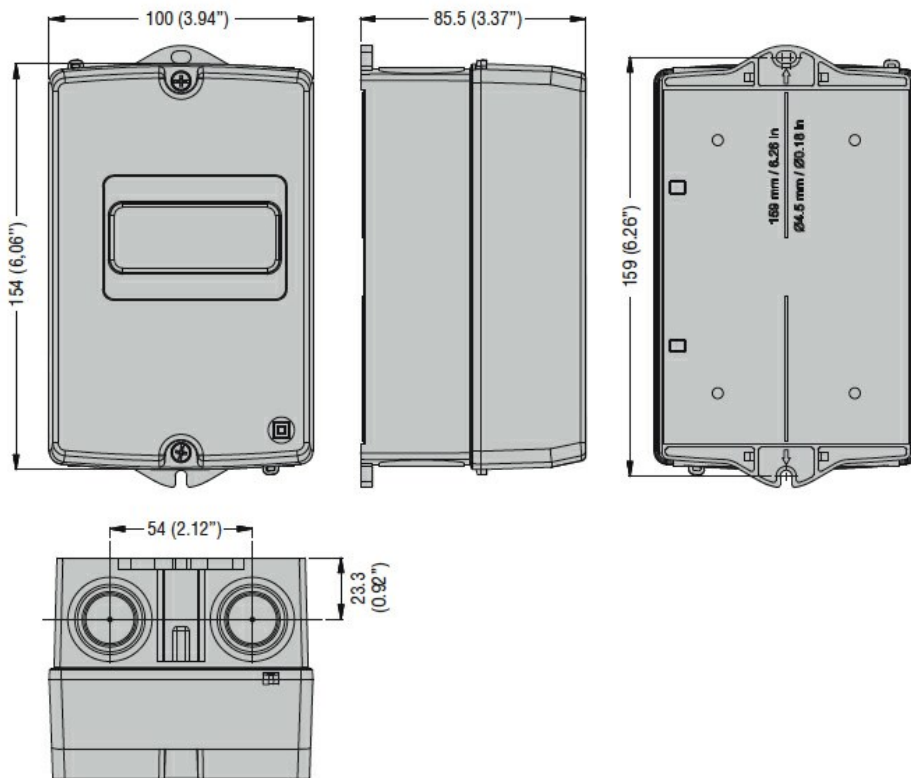

## Certifications and compliance

### Compliance

CSA C22.2 n° 14

IEC/EN 60947-1

IEC/EN 60947-5-1

UL508

### Certificates

cULus

EAC

## ETIM classification

□