



Double-touch actuators, spring return white indicator - Two flush pushbuttons LPCBL71

Product designation

Product type designation

General characteristics

Colour	Green/Red
Type of positions	Double-touch with two flush pushbuttons
Material	Polyamide
IEC degree of protection	IP66, IP67 and IP69K

Mechanical features

Operating force	kg-lb	<0.5Kg / 1.1lb
Mechanical life	cycles	1000000
Mounting adapter		LPXAU120
Weight	g	30

UL technical data

UL degree of protection	Type1, 2, 3R, 4, 4X, 12, 12K
-------------------------	------------------------------

Ambient conditions

Temperature

Operating temperature

min	°C	-25
max	°C	+70

Storage temperature

min	°C	-40
max	°C	+85

Dimensions [mm (in)]

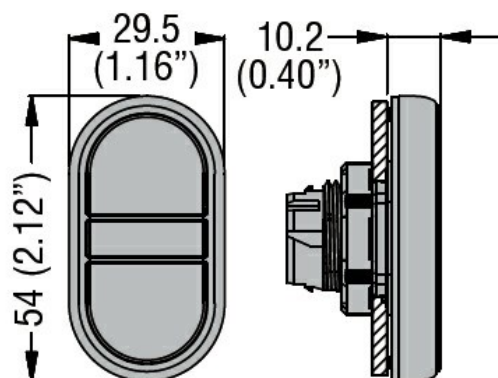

Certifications and compliance

Compliance

CSA C22.2 n° 14

IEC/EN/BS 60947-1

IEC/EN/BS 60947-5-1

UL508

Certificates

CCC

cULus

EAC

RINA

ETIM classification

ETIM 8.0

EC000221 -
Front element for
push button