

PSR-SCP- 24UC/ESL4/3X1/1X2/B - Safety relays



2981059

<https://www.phoenixcontact.com/gb/products/2981059>

Please be informed that the data shown in this PDF document is generated from our online catalog. Please find the complete data in the user documentation. Our general terms of use for downloads are valid.



Safety relay for emergency stop, safety doors, and light grids up to SIL 3, Cat. 4, PL e, 1 or 2-channel operation, automatic or manual, monitored start, 3 enabling current paths, $U_S = 24 \text{ V DC}$, plug-in screw terminal block

Your advantages

- Manually monitored and automatic activation
- Up to Cat. 4/PL e in accordance with ISO 13849-1, SIL 3 in accordance with EN IEC 62061, SIL 3 in accordance with IEC 61508
- Three enabling and one signaling current path
- 1- and 2-channel control

Technical data

Product properties

Product type	Safety relays
Product family	PSRclassic
Application	Emergency stop
	Safety door
	Light grid
Mechanical service life	approx. 10^7 cycles
Relay type	Electromechanical relay with force-guided contacts in accordance with IEC/EN 61810-3

Times

Typical response time	125 ms (automatic start)
	110 ms (manual, monitored start)
Typ. starting time with U_S	125 ms (when controlled via A1)
Typical release time	10 ms (on demand via the sensor circuit)
	45 ms (on demand via A1)
Restart time	< 1 s (Boot time)
Recovery time	1 s (following demand of the safety function)

Electrical properties

Maximum power dissipation for nominal condition	16.44 W (at $U_S = 26.4$ V, $I_L^2 = 72$ A ² ; $P_{Total\ max} = 2.04$ W + 14.4 W)
Nominal operating mode	100% operating factor

Air clearances and creepage distances between the power circuits

Rated insulation voltage	250 V
	250 V
Rated surge voltage/insulation	See section "Insulation coordination"

Supply

Rated control circuit supply voltage U_S	24 V DC -15 % / +10 %
Rated control supply current I_S	typ. 70 mA (at U_S)
Power consumption at U_S	typ. 1.68 W
Inrush current	< 3.5 A (typically with U_S , $\Delta t = 3$ ms)
Filter time	5 ms (in the event of voltage dips at U_S , no test pulses allowed)
Protective circuit	Serial protection against polarity reversal; Suppressor diode

Input data

Digital: Logic (S12, S22)

Description of the input	safety-related
Number of inputs	2
Input voltage range "0" signal	0 V DC ... 5 V DC
Input voltage range "1" signal	20.4 V ... 26.4 V
Input current range "0" signal	0 mA ... 2 mA

PSR-SCP- 24UC/ESL4/3X1/1X2/B - Safety relays



2981059

<https://www.phoenixcontact.com/gb/products/2981059>

Inrush current	max. 110 mA (typically with U_S , $\Delta t = 3$ ms)
Filter time	max. 2 ms (Test pulse width low test pulses, at 100 ms test pulse rate)
	No brightness test pulses / high test pulses permitted.
Concurrency	∞
Max. permissible overall conductor resistance	50 Ω
Protective circuit	Suppressor diode
Current consumption	38 mA (typically with U_S)

Digital: Start circuit (S34, S35)

Description of the input	non-safety-related
Number of inputs	2
Input voltage range "1" signal	20.4 V ... 26.4 V
Inrush current	< 6 mA (typically with U_S at S34/35, $\Delta t = 70$ ms)
Filter time	No test pulses permitted
Max. permissible overall conductor resistance	50 Ω
Protective circuit	Suppressor diode
Current consumption	0 mA (Typically with U_S at S34)
	1 mA (Typically with U_S at S35)

Output data

Relay: Enabling current paths (13/14, 23/24, 33/34)

Output description	2 N/O contacts each in series, safety-related, floating
Number of outputs	3
Contact switching type	3 enabling current paths
Contact material	AgSnO ₂
Switching voltage	min. 10 V
	max. 250 V AC
Switching capacity	min. 100 mW
Inrush current	min. 10 mA
	max. 6 A
Switching capacity in accordance with IEC 60947-5-1	5 A (AC15)
	6 A (DC13)
Limiting continuous current	6 A (Observe derating and load limit curve)
Sq. Total current	72 A ² (observe derating)
Switching frequency	max. 0.5 Hz
Mechanical service life	10x 10 ⁶ cycles
Output fuse	10 A gL/gG
	4 A gL/gG (for low-demand applications)

Relay: Signaling current path (41/42)

Output description	2 N/C contacts parallel, non-safety-related, floating
Number of outputs	1
Contact switching type	1 signaling current path
Contact material	AgSnO ₂

PSR-SCP- 24UC/ESL4/3X1/1X2/B - Safety relays



2981059

<https://www.phoenixcontact.com/gb/products/2981059>

Switching voltage	min. 10 V AC/DC
	max. 250 V AC
Switching capacity	min. 100 mW
Inrush current	min. 10 mA
	max. 6 A
Switching capacity in accordance with IEC 60947-5-1	1.5 A (AC15)
	2 A (DC13)
Limiting continuous current	6 A
Sq. Total current	36 A ² (observe derating)
Switching frequency	max. 0.5 Hz
Mechanical service life	10x 10 ⁶ cycles
Output fuse	6 A gL/gG

Connection data

Connection technology

pluggable	yes
-----------	-----

Conductor connection

Connection method	Screw connection
Conductor cross section rigid	0.2 mm ² ... 2.5 mm ²
Conductor cross section flexible	0.2 mm ² ... 2.5 mm ²
Conductor cross-section AWG	24 ... 12
Stripping length	7 mm
Screw thread	M3
Tightening torque	0.5 Nm ... 0.6 Nm

Signaling

Status display	2 x green LEDs
Operating voltage display	1 x green LED

Dimensions

Width	22.5 mm
Height	99 mm
Depth	114.5 mm

Material specifications

Color (Housing)	yellow (RAL 1018)
Housing material	Polyamide

Characteristics

Safety data

Stop category	0
---------------	---

Safety data: EN ISO 13849

Category	4
----------	---

Performance level (PL)	e (5 A DC13; 5 A AC15; 8760 switching cycles/year)
Safety data: IEC 61508 - High demand	
Safety Integrity Level (SIL)	3
Safety data: IEC 61508 - Low demand	
Safety Integrity Level (SIL)	3
Safety data: EN IEC 62061	
Safety Integrity Level (SIL)	3

Environmental and real-life conditions

Ambient conditions

Degree of protection	IP20
Min. degree of protection of inst. location	IP54
Ambient temperature (operation)	-20 °C ... 55 °C (observe derating)
Ambient temperature (storage/transport)	-40 °C ... 70 °C
Maximum altitude	≤ 2000 m (Above sea level)
Max. permissible humidity (storage/transport)	75 % (on average, 85% infrequently, non-condensing)
Max. permissible relative humidity (operation)	75 % (on average, 85% infrequently, non-condensing)
Shock	15g
Vibration (operation)	10 Hz ... 150 Hz, amplitude 0.15 mm, 2g

Approvals

CE

Identification	CE-compliant
----------------	--------------

Standards and regulations

Air clearances and creepage distances between the power circuits

Standards/regulations	DIN EN 60947-1
-----------------------	----------------

Mounting

Mounting type	DIN rail mounting
Assembly instructions	See derating curve
Mounting position	vertical or horizontal

PSR-SCP- 24UC/ESL4/3X1/1X2/B - Safety relays



2981059

<https://www.phoenixcontact.com/gb/products/2981059>

Drawings

Circuit diagram

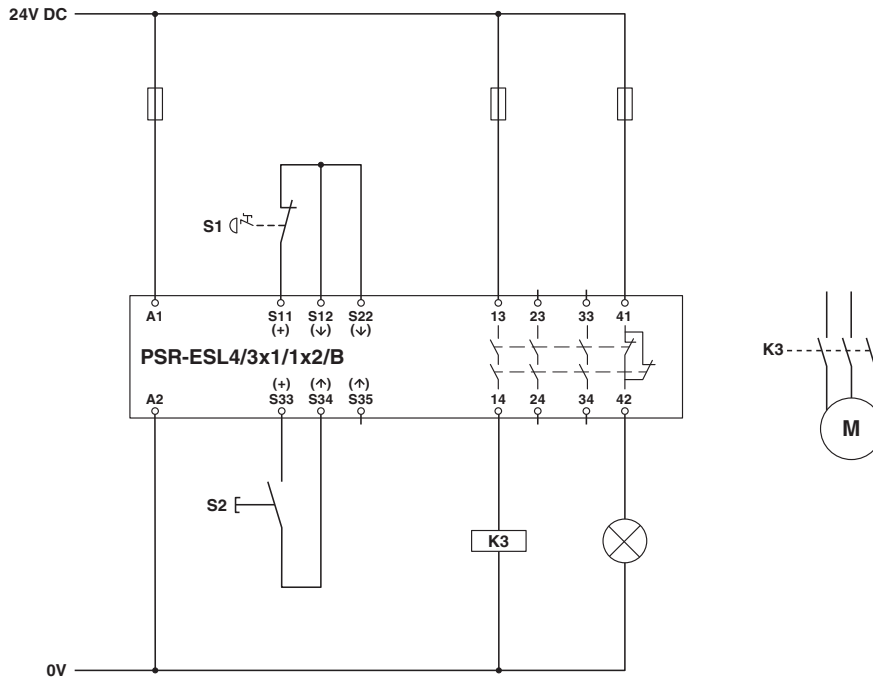

Circuit diagram

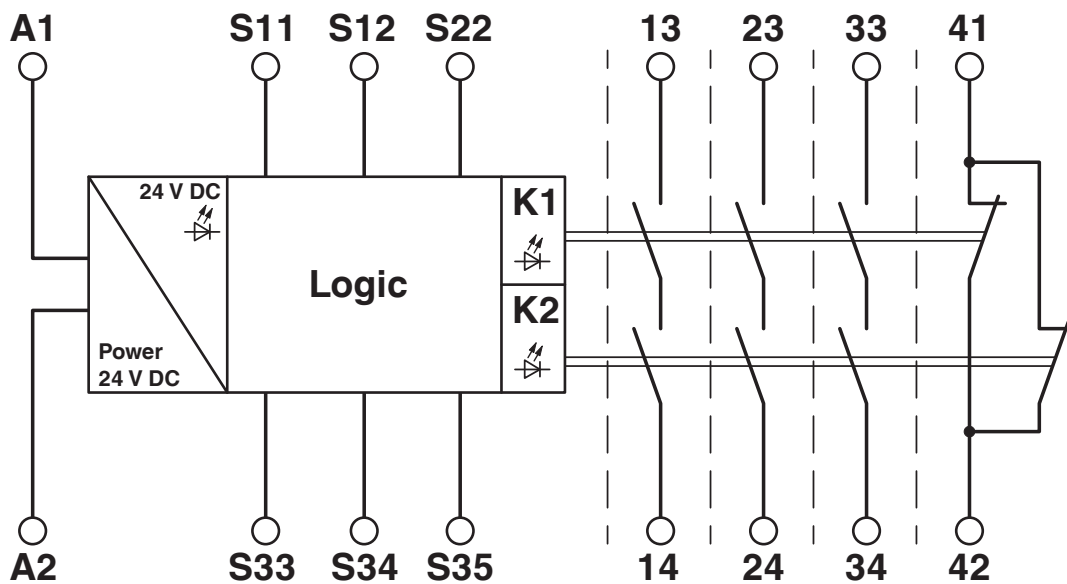

PSR-SCP- 24UC/ESL4/3X1/1X2/B - Safety relays



2981059

<https://www.phoenixcontact.com/gb/products/2981059>

Circuit diagram

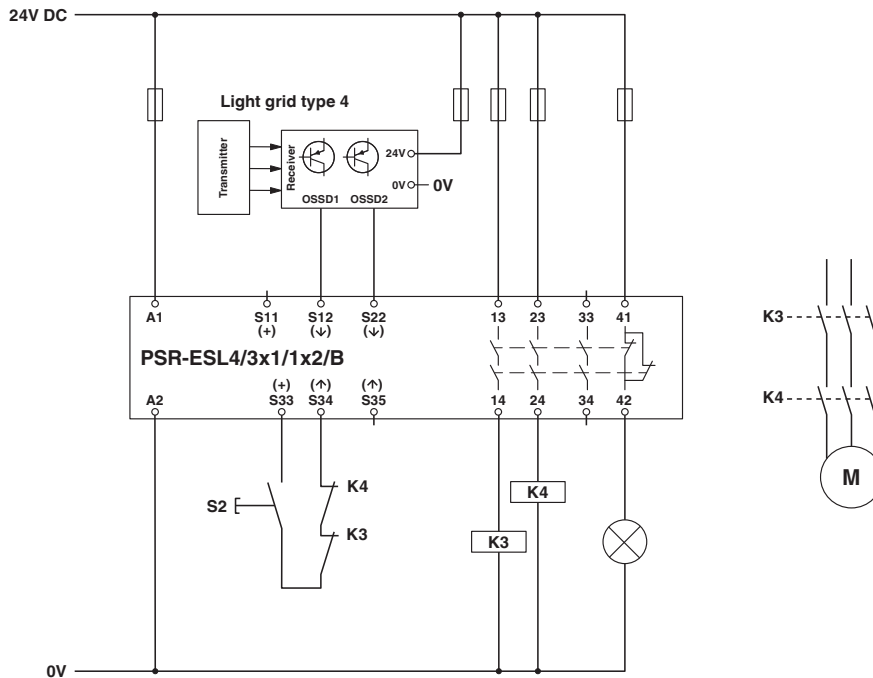

Circuit diagram

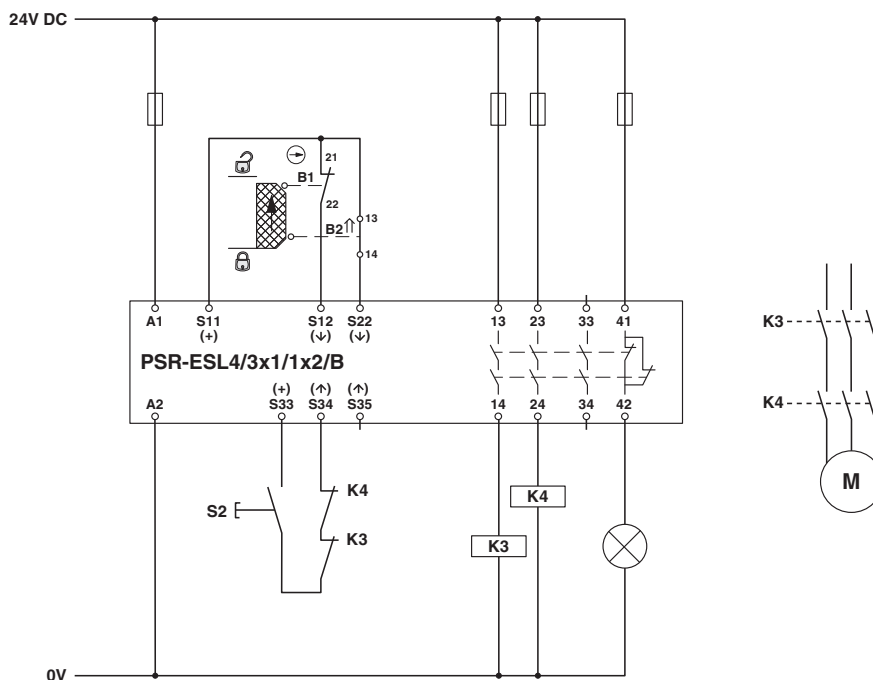

PSR-SCP- 24UC/ESL4/3X1/1X2/B - Safety relays



2981059

<https://www.phoenixcontact.com/gb/products/2981059>

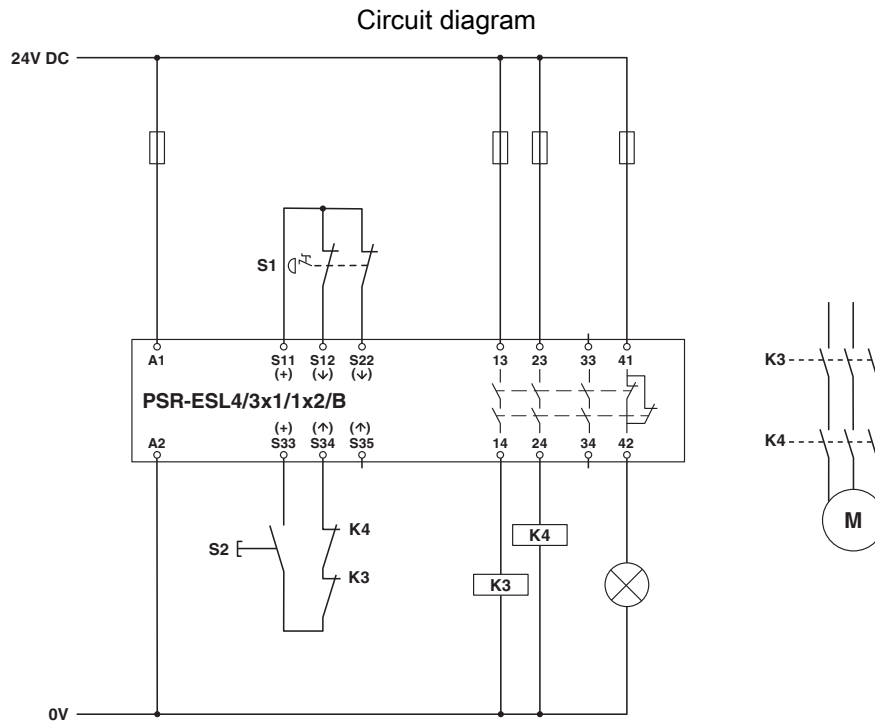

Phoenix Contact 2024 © - all rights reserved
<https://www.phoenixcontact.com>

PHOENIX CONTACT Ltd
Halesfield 13, Telford
Shropshire, TF7 4PG
01952 681700
info@phoenixcontact.co.uk