

Flexi Soft Modular Safety Controller

Hardware

SICK
Sensor Intelligence.

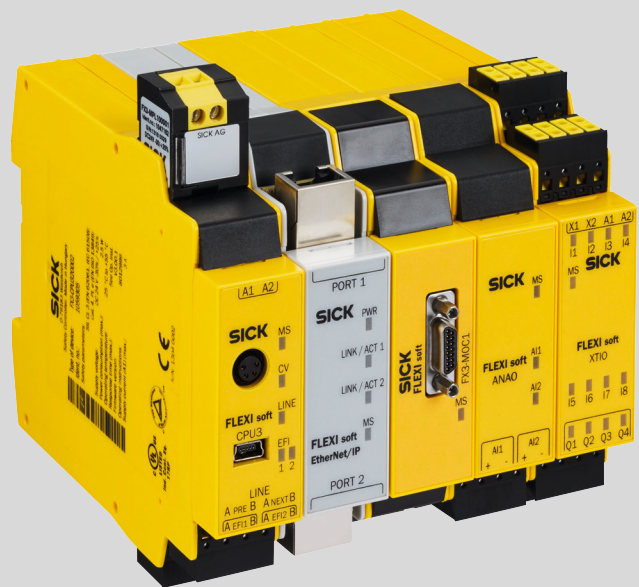

Described product

Flexi Soft Modular Safety Controller

Hardware

Manufacturer

SICK AG
Erwin-Sick-Str. 1
79183 Waldkirch
Germany

Legal information

This work is protected by copyright. Any rights derived from the copyright shall be reserved for SICK AG. Reproduction of this document or parts of this document is only permissible within the limits of the legal determination of Copyright Law. Any modification, abridgment or translation of this document is prohibited without the express written permission of SICK AG.

The trademarks stated in this document are the property of their respective owner.

© SICK AG. All rights reserved.

Original document

This document is an original document of SICK AG.



Contents

| | | |
|----------|--|-----------|
| 1 | About this document..... | 7 |
| 1.1 | Purpose of this document..... | 7 |
| 1.2 | Scope..... | 8 |
| 1.3 | Target groups of these operating instructions..... | 9 |
| 1.4 | Further information..... | 9 |
| 1.5 | Symbols and document conventions..... | 9 |
| 2 | Safety information..... | 11 |
| 2.1 | General safety notes..... | 11 |
| 2.2 | Intended use..... | 12 |
| 2.3 | Requirements for the qualification of personnel..... | 13 |
| 3 | Product description..... | 14 |
| 3.1 | System characteristics..... | 14 |
| 3.2 | Version, compatibility, and features..... | 14 |
| 3.3 | Construction and function..... | 17 |
| 3.4 | Modules..... | 19 |
| 3.4.1 | FX3-CPU0 main module..... | 20 |
| 3.4.2 | FX3-CPU1 main module..... | 20 |
| 3.4.3 | FX3-CPU2 main module..... | 21 |
| 3.4.4 | FX3-CPU3 main module..... | 22 |
| 3.4.5 | FX3-MPL0 and FX3-MPL1 system plugs..... | 23 |
| 3.4.6 | FX3-XTIO I/O module..... | 24 |
| 3.4.7 | FX3-XTDI I/O module..... | 28 |
| 3.4.8 | FX3-XTDS I/O module..... | 30 |
| 3.4.9 | FX0-STIO I/O module..... | 32 |
| 3.4.10 | Motion Control FX3-MOCO..... | 34 |
| 3.4.11 | Motion Control FX3-MOC1..... | 36 |
| 3.4.12 | FX3-ANA0 analog input module..... | 39 |
| 3.4.13 | UE410-2RO/UE410-4RO relay modules..... | 41 |
| 3.5 | Interfaces..... | 42 |
| 3.5.1 | RS-232..... | 42 |
| 3.5.2 | USB..... | 43 |
| 3.5.3 | Enhanced Function Interface (EFI)..... | 44 |
| 3.6 | Special functions..... | 45 |
| 3.6.1 | Flexi Link..... | 45 |
| 3.6.2 | Flexi Line..... | 46 |
| 3.6.3 | Muting..... | 47 |
| 3.6.4 | Automatic configuration recovery (ACR)..... | 47 |
| 4 | Mounting..... | 49 |
| 4.1 | Mounting procedure..... | 49 |
| 5 | Electrical installation..... | 51 |

| | | |
|----------|--|------------|
| 5.1 | Requirements to be met by the electrical installation..... | 51 |
| 5.2 | Description of the terminals..... | 53 |
| 5.2.1 | FX3-CPU0 main module..... | 53 |
| 5.2.2 | FX3-CPU1 and FX3-CPU2 main modules..... | 54 |
| 5.2.3 | FX3-CPU3 main module..... | 56 |
| 5.2.4 | FX3-XTIO I/O module..... | 57 |
| 5.2.5 | FX3-XTDI I/O module..... | 58 |
| 5.2.6 | FX3-XTDS I/O module..... | 59 |
| 5.2.7 | FX0-STIO I/O module..... | 60 |
| 5.2.8 | FX3-MOCx motion control module..... | 60 |
| 5.2.9 | Encoder/motor feedback connection units..... | 62 |
| 5.2.10 | FX3-EBX connecting cables..... | 70 |
| 5.2.11 | Encoder connection cables..... | 71 |
| 5.2.12 | FX3-ANA0 analog input module..... | 75 |
| 5.2.13 | UE410-2RO and UE410-4RO relay modules..... | 76 |
| 5.3 | Wiring for the power supply to a Flexi Soft system..... | 78 |
| 5.4 | Connection of devices..... | 78 |
| 5.4.1 | Safety command devices and electro-mechanical safety switches..... | 80 |
| 5.4.2 | Non-contact safety switches..... | 86 |
| 5.4.3 | Testable safety single-beam sensors..... | 87 |
| 5.4.4 | Electro-sensitive protective devices..... | 91 |
| 5.4.5 | Safety outputs Q1 to Q4..... | 91 |
| 5.4.6 | Connection of EFI-enabled devices..... | 92 |
| 5.4.7 | Connection of a Pro-face HMI..... | 93 |
| 5.4.8 | Connection of encoders..... | 94 |
| 5.4.9 | Connecting analog sensors..... | 98 |
| 5.4.10 | Connecting Flexi-Link system..... | 100 |
| 5.4.11 | Connecting Flexi-Line system..... | 102 |
| 5.4.12 | EMC measures for Flexi Link and Flexi Line..... | 103 |
| 6 | Configuration..... | 105 |
| 6.1 | Configuration..... | 105 |
| 7 | Commissioning..... | 107 |
| 7.1 | Final acceptance of the application..... | 107 |
| 7.2 | Checks before initial commissioning..... | 107 |
| 8 | Operation..... | 108 |
| 8.1 | Status messages on the FX3-CPUx main module..... | 108 |
| 8.2 | Status messages for the FX3-XTIO I/O module..... | 109 |
| 8.3 | Status messages for the FX3-XTDI I/O module..... | 110 |
| 8.4 | Status messages for the FX3-XTDS I/O module..... | 111 |
| 8.5 | Status messages for the FX0-STIO I/O module..... | 112 |
| 8.6 | Status signals of the FX3-ANA0 analog input module..... | 113 |
| 8.7 | Status messages of the FX3-MOCx motion control module..... | 114 |

| | | |
|-----------|--|------------|
| 8.8 | Status messages of the UE410-2RO and UE410-4RO relay modules.. | 115 |
| 9 | Maintenance..... | 116 |
| 9.1 | Regular thorough check of the safety function by qualified safety personnel..... | 116 |
| 9.2 | Device replacement..... | 116 |
| 10 | Troubleshooting..... | 118 |
| 10.1 | Response to errors..... | 118 |
| 10.2 | Error states..... | 118 |
| 10.3 | Error displays shown by status LEDs, error messages, and troubleshooting measures..... | 119 |
| 10.4 | Error history..... | 127 |
| 10.5 | Measures against common causes of error..... | 127 |
| 10.6 | SICK support..... | 129 |
| 11 | Decommissioning..... | 130 |
| 11.1 | Removal..... | 130 |
| 11.2 | Disposal..... | 131 |
| 12 | Technical data..... | 132 |
| 12.1 | Minimum switch-off time..... | 132 |
| 12.2 | Maximum response time of the Flexi Soft system..... | 132 |
| 12.2.1 | Calculation of the response time..... | 134 |
| 12.3 | Data sheet..... | 141 |
| 12.3.1 | Main modules CPU0, CPU1, CPU2 and CPU3..... | 141 |
| 12.3.2 | I/O module XTIO..... | 143 |
| 12.3.3 | I/O module XTDI..... | 147 |
| 12.3.4 | I/O module XTDS..... | 149 |
| 12.3.5 | I/O module STIO..... | 152 |
| 12.3.6 | Analog input module ANA0..... | 154 |
| 12.3.7 | Motion Control MOCO..... | 156 |
| 12.3.8 | Motion Control MOC1..... | 161 |
| 12.3.9 | EBX1, EBX3 and EBX4 encoder/motor feedback connection units..... | 167 |
| 12.3.10 | Relay modules UE410-2RO/UE410-4RO..... | 168 |
| 12.3.11 | Diode module DM8-A4K..... | 172 |
| 12.4 | Dimensional drawings..... | 173 |
| 12.4.1 | FX3-CPUx main modules with system plug..... | 173 |
| 12.4.2 | FX3-XTIO, FX3-XTDI, FX3-XTDS, and FX0-STIO I/O modules, UE410-2RO and UE410-4RO relay modules..... | 174 |
| 12.4.3 | FX3-ANA0 analog input module..... | 175 |
| 12.4.4 | FX3-MOCx motion control module..... | 176 |
| 12.4.5 | FX3-EBX1, FX3-EBX3, and FX3-EBX4 encoder/motor feedback connection boxes..... | 177 |
| 12.4.6 | Diode module DM8-A4K..... | 180 |
| 13 | Ordering information..... | 181 |

| | | |
|-----------|--|------------|
| 13.1 | System plugs and modules..... | 181 |
| 14 | Accessories..... | 184 |
| 14.1 | Accessories for the safety controller..... | 184 |
| 14.2 | Accessories for the motion control module..... | 184 |
| 14.3 | Accessories for the diode module..... | 186 |
| 14.4 | Accessories for muting..... | 186 |
| 15 | Glossary..... | 187 |
| 16 | Annex..... | 190 |
| 16.1 | Conformities and certificates..... | 190 |
| 16.1.1 | EU declaration of conformity..... | 190 |
| 16.1.2 | UK declaration of conformity..... | 190 |
| 16.2 | Note on standards..... | 190 |
| 16.3 | Checklist for initial commissioning and commissioning..... | 192 |
| 17 | List of figures..... | 193 |
| 18 | List of tables..... | 195 |

1 About this document

1.1 Purpose of this document

These operating instructions contain the information required during the life cycle of the Flexi Soft modular safety controller.

These operating instructions are to be made available to all those who work with the Flexi Soft modular safety controller.

For the Flexi Soft system, there are operating instructions and mounting instructions, each covering clearly defined fields of application.

Table 1: Overview of the Flexi Soft documentation

| Document type | Title | Contents | Purpose | Part number |
|------------------------|---|--|--|-------------|
| Operating instructions | Flexi Soft Modular Safety Controller Hardware | Description of the Flexi Soft modules and their functions | Instructions for technical personnel working for the machine manufacturer or operator on the safe mounting, electrical installation, and maintenance of the Flexi Soft safety controller | 8012999 |
| Operating instructions | Flexi Soft in the Flexi Soft Designer Configuration software | Description of the software-based configuration of the Flexi Soft safety controller along with important diagnostics functions and detailed notes on identifying and rectifying errors | Instructions for technical personnel working for the machine manufacturer or operator on the safe configuration and commissioning, as well as the safe operation, of the Flexi Soft safety controller | 8012998 |
| Operating instructions | Safety Designer Configuration software | Description of the installation and general basic principles of operation | To provide technical personnel working for the machine manufacturer/operator with instructions so that they can use the Safety Designer configuration software | 8018178 |
| Operating instructions | Flexi Soft in the Safety Designer Configuration software | Description of the software-based configuration of the Flexi Soft safety controller along with important diagnostics functions and detailed notes on identifying and rectifying errors | Instructions for technical personnel working for the machine manufacturer or operator on the safe configuration and commissioning, as well as the safe operation, of the Flexi Soft safety controller | 8013926 |
| Operating instructions | Flexi Soft Gateways Hardware | Description of the Flexi Soft gateways and their functions | To provide technical personnel working for the machine manufacturer/operator with instructions so that they can safely carry out the mounting, electrical installation, and maintenance work for the Flexi Soft gateways | 8012662 |
| Operating instructions | Flexi Soft Gateways in Flexi Soft Designer Configuration software | Description of the software-based configuration of the Flexi Soft gateway, information about data exchange in networks as well as about the status, planning, and associated mapping | To provide technical personnel working for the machine manufacturer/operator with instructions so that they can safely configure and commission the Flexi Soft gateways | 8012483 |

1 ABOUT THIS DOCUMENT

| Document type | Title | Contents | Purpose | Part number |
|------------------------|--|--|---|-------------|
| Operating instructions | Flexi Soft Gateways in the Safety Designer Configuration software | Description of the software-based configuration of the Flexi Soft gateway, information about data exchange in networks as well as about the status, planning, and associated mapping | To provide technical personnel working for the machine manufacturer/operator with instructions so that they can safely configure and commission the Flexi Soft gateways | 8018170 |
| Operating instructions | Flexi Loop safe series connection Hardware | Description of the Flexi Loop safe series connection and its functions | To provide technical personnel working for the machine manufacturer/operator with instructions so that they can safely carry out the mounting, electrical installation, and maintenance work for the Flexi Loop safe series connection | 8015834 |
| Operating instructions | Flexi Loop in the Flexi Soft Designer configuration software | Description of how to configure and set the parameters for the Flexi Loop safe series connection using software | To provide technical personnel working for the machine manufacturer/operator with instructions so that they can safely configure and commission the Flexi Loop safe series connection | 8014521 |
| Operating instructions | Flexi Loop in Safety Designer Configuration software | Description of how to configure and set the parameters for the Flexi Loop safe series connection using software | To provide technical personnel working for the machine manufacturer/operator with instructions so that they can safely configure and commission the Flexi Loop safe series connection | 8018174 |
| Mounting instructions | Flexi Soft FX3-EBX3 and FX3-EBX4 Encoder/Motor Feedback Connection Boxes | Description of FX3-EBX3 and FX3-EBX4 encoder/motor feedback connection boxes | To provide technical personnel working for the machine manufacturer/operator with instructions so that they can safely carry out the mounting, electrical installation, commissioning, and maintenance work for FX3-EBX3 and FX3-EBX4 encoder/motor feedback connection boxes | 8015600 |
| Mounting instructions | Flexi Soft FX3-EBX1 Optimized Dual Encoder/Motor Feedback Connection Box | Description of the FX3-EBX1 optimized dual encoder/motor feedback connection box | To provide technical personnel working for the machine manufacturer/operator with instructions so that they can safely carry out the mounting, electrical installation, commissioning, and maintenance work for the FX3-EBX1 optimized dual encoder/motor feedback connection box | 8019030 |

1.2 Scope

Product

These operating instructions apply to all modules of the Flexi Soft safety controller with the exception of the Flexi Soft gateway.

Document identification**Document part number:**

- This document: 8012478
- Available language versions of this document: 8012999

You can find the current version of all documents at www.sick.com.

1.3 Target groups of these operating instructions

Some sections of these operating instructions are intended for certain target groups. However, the entire operating instructions are relevant for intended use of the product.

Table 2: Target groups and selected sections of these operating instructions

| Target group | Sections of these operating instructions |
|--|--|
| Project developers (planners, developers, designers) | "Configuration", page 105 "Technical data", page 132 |
| Installers | "Mounting", page 49 |
| Electricians | "Electrical installation", page 51 |
| Safety experts (such as CE authorized representatives, compliance officers, people who test and approve the application) | "Configuration", page 105 "Commissioning", page 107 "Technical data", page 132 |
| Operators | "Operation", page 108 "Troubleshooting", page 118 |
| Maintenance personnel | "Maintenance", page 116 "Troubleshooting", page 118 |

1.4 Further information

www.sick.com

The following information is available via the Internet:

- Data sheets and application examples
- CAD files and dimensional drawings
- Certificates (such as the EU declaration of conformity)
- Guide for Safe Machinery Six steps to a safe machine
- Safety Designer (software for configuring safety solutions made by SICK AG)
- Flexi Soft Designer (software for configuring the Flexi Soft safety controller)

1.5 Symbols and document conventions

The following symbols and conventions are used in this document:

Warnings and other notes**DANGER**

Indicates a situation presenting imminent danger, which will lead to death or serious injuries if not prevented.

**WARNING**

Indicates a situation presenting possible danger, which may lead to death or serious injuries if not prevented.

**CAUTION**

Indicates a situation presenting possible danger, which may lead to moderate or minor injuries if not prevented.

**NOTICE**

Indicates a situation presenting possible danger, which may lead to property damage if not prevented.

**NOTE**

Highlights useful tips and recommendations as well as information for efficient and trouble-free operation.

Instructions to action

- ▶ The arrow denotes instructions to action.
- 1. The sequence of instructions for action is numbered.
- 2. Follow the order in which the numbered instructions are given.
- ✓ The check mark denotes the result of an instruction.

LED symbols

These symbols indicate the status of an LED:

- The LED is off.
- ◐ The LED is flashing.
- The LED is illuminated continuously.

2 Safety information

2.1 General safety notes

Integrating the product

**DANGER**

The product can not offer the expected protection if it is integrated incorrectly.

- ▶ Plan the integration of the product in accordance with the machine requirements (project planning).
 - ▶ Implement the integration of the product in accordance with the project planning.
-

Mounting and electrical installation

**DANGER**

Death or severe injury due to electrical voltage and/or an unexpected startup of the machine

- ▶ Make sure that the machine is (and remains) disconnected from the voltage supply during mounting and electrical installation.
 - ▶ Make sure that the dangerous state of the machine is and remains switched off.
-

**WARNING**

Improper mounting or use

The target safety-related level may not be achieved in the event of non-compliance.

- ▶ When mounting, installing, and using the Flexi Soft safety controller, remember to observe all applicable standards and directives.
 - ▶ Observe the relevant national and international legal provisions for the installation and use of the Flexi Soft safety controller, its commissioning, and technical inspections repeated at regular intervals.
 - ▶ The manufacturer and operator of the machine on which the Flexi Soft safety controller is used are responsible for liaising with the relevant authorities about all applicable safety regulations/rules and for ensuring compliance with these.
 - ▶ The notes, in particular the test notes, in these operating instructions (e.g. regarding use, mounting, installation, or integration into the machine controller) must always be observed.
 - ▶ The thorough checks must be carried out by qualified safety personnel or specially qualified and authorized personnel, and must be recorded and documented by a third party to ensure that the tests can be reconstructed and retraced at any time.
-

Configuration



WARNING

Ineffectiveness of the protective device due to incorrect configuration

The dangerous state may not be stopped or not be stopped in a timely manner in the event of non-compliance.

The target safety-related level may not be achieved in the event of non-compliance.

- ▶ Check whether the configured safety application monitors the machine or plant as intended and if the safety of the configured application is maintained at all times. This must be ensured in every operating mode and secondary application. Document the results of this thorough check.
 - ▶ Check the safety function again after any change to the configuration.
 - ▶ Observe the testing information in the operating instructions for the connected protective devices.
-

Repairs and modifications



DANGER

Improper work on the product

A modified product may not offer the expected protection if it is integrated incorrectly.

- ▶ Apart from the procedures described in this document, do not repair, open, manipulate or otherwise modify the product.
-

2.2 Intended use

The Flexi Soft modular safety controller is an adjustable control for safety applications.

It is to be used in accordance with the following standards:

- IEC 61508 and IEC 62061 up to SIL3
- ISO 13849 up to performance level e

The safety level actually achieved is determined by the external wiring, how the wiring is implemented, the configuration, the selection of command triggers, and how they are arranged on the machine.

The product may be used in safety functions.

The product must only be used within the limits of the prescribed and specified technical specifications and operating conditions at all times.

Incorrect use, improper modification or manipulation of the product will invalidate any warranty from SICK; in addition, any responsibility and liability of SICK for damage and secondary damage caused by this is excluded.

The product is only suitable for use in industrial environments.

UL/CSA applications:

If the product is being used in accordance with UL 508 or CSA C 22.2 No. 142, the following conditions must also be met:

- To protect the device's 24-volt voltage supply, use a fuse with a maximum voltage of 4 A and a minimum of 30 V DC in accordance with UL 248.
- For wiring, only use copper wires with a temperature resistance of at least 60 °C / 75 °C, wire cross-section AWG 30–12 for screw terminals and/or AWG 24–16 for spring terminals.
- Tighten the screw terminals with a torque of 5 to 7 lb-in.
- Only use the devices in an environment with maximum degree of contamination 2.

**NOTE**

The safety functions have not be evaluated by UL. Authorization is in accordance with UL 508, general applications.

2.3 Requirements for the qualification of personnel

The product must be configured, installed, connected, commissioned, and serviced by qualified safety personnel only.

Project planning

You need safety expertise to implement safety functions and select suitable products for that purpose. You need expert knowledge of the applicable standards and regulations.

Mounting, electrical installation and commissioning

You need suitable expertise and experience. You must be able to assess if the machine is operating safely.

Configuration

You need suitable expertise and experience. You must be able to assess if the machine is operating safely.

Operation and maintenance

You need suitable expertise and experience. You must be instructed in machine operation by the machine operator. For maintenance, you must be able to assess if the machine is operating safely.

3 Product description

3.1 System characteristics

Sensors and switching elements (e.g. light curtains, laser scanners, switches, sensors, encoders, emergency stop pushbutton) are connected to the Flexi Soft modular safety controller and are linked logically. The corresponding actuators of the machines or systems can be switched off safely via the switching outputs of the safety controller.

The Flexi Soft system is distinguished by the following system characteristics:

- Modular design: 1 main module, up to 2 different gateways, and up to 12 expansion modules ¹⁾
- Up to 96 safe digital inputs
- Up to 12 safe analog inputs ²⁾
- Up to 48 safe digital outputs or up to 96 non-safe digital outputs
- Configurable
- Use of up to 255 logic and application-specific function blocks
- Logic function blocks, including, e.g., AND, OR, NOT, XNOR, XOR
- Application-specific function blocks including, e.g., emergency stop, two-hand, muting, presses, ramp-down detection, operating mode selector switch, reset, restart
- Can be integrated into different networks with gateways (EtherNet/IP™, Modbus TCP, PROFINET IO, PROFIBUS DP, DeviceNet, CANopen and EtherCAT)
- Safe gateway for EFI-pro
- 2 EFI interfaces on FX3-CPU1, FX3-CPU2, and FX3-CPU3 main modules (see "FX3-CPU1 main module", page 20)

The Flexi Soft Designer and Safety Designer configuration softwares are available for configuration of the control tasks.



NOTE

The available range of performance of the Flexi Soft systems depends on the configuration software used, see "Version, compatibility, and features", page 14.

You will find the configuration software on the Internet: www.sick.com

3.2 Version, compatibility, and features

There are different firmware versions and function packages (so-called "Steps") for the Flexi Soft product family that permit realization of the different functions. This section provides an overview of which firmware version, which function package and/or which version of the Flexi Soft Designer configuration software or Safety Designer configuration software is needed to use a certain function or a certain device.

Table 3: Modules, firmware versions, and software versions you will need

| | Necessary module with firmware from version | Available from Flexi Soft Designer | Available from Safety Designer |
|---|---|------------------------------------|--------------------------------|
| Function blocks and logic | | | |
| Offline simulation of logic | Unrestricted | V1.2.0 | V1.6.x |
| Import and export of partial applications | Unrestricted | V1.3.0 | V1.6.x |

1) The number of expansion modules is limited by the capacity of the FLEXBUS+ backplane bus. A motion control module (FX3-MOCx) requires twice the bus capacity of the other expansion modules. Therefore, each FX3-MOCx reduces the maximum possible number of expansion modules that can be used by two.

2) Each FX3-ANA0 expansion module provides two analog inputs, which are combined to form one safe channel. An FX3-ANA0 can therefore safely detect an analog process variable using two sensors.

| | Necessary module with firmware from version | Available from Flexi Soft Designer | Available from Safety Designer |
|---|--|--|--------------------------------|
| Automatic circuit diagrams | Unrestricted | V1.3.0 | V1.6.x |
| Central tag name editor | Unrestricted | V1.3.0 | V1.6.x |
| Documentation for function blocks of main modules in logic editor | Unrestricted | V1.3.0 | N. a. ¹⁾ |
| Matrix of input and output connections | Unrestricted | V1.3.0 | V1.6.x |
| Invertible inputs for the function blocks AND, OR, RS Flip-Flop and Routing n:n | FX3-CPUx V2.00.0 (Step 2.xx) | V1.3.0 | V1.6.x |
| Function block for ramp-down detection | FX3-CPUx V1.11.0 (Step 1.xx) | V1.3.0 | V1.6.x |
| Function blocks for configurable switch-on delay and configurable switch-off delay | FX3-CPUx V2.00.0 (Step 2.xx) | V1.3.0 | V1.6.x |
| Speed to Bool function block | FX3-MOC0 V1.10.0 | V1.7.0 | V1.6.x |
| Motion Status to Bool function block | FX3-MOC0 V1.10.0 | V1.7.0 | V1.6.x |
| Function block for type IIIA two-hand control: Configurable discrepancy time | FX3-CPUx V4.05.0 | V1.9.6 SP1 | V2023.01 |
| Function block for type IIIC two-hand control: Configurable synchronization time | FX3-CPUx V4.05.0 | V1.9.6 SP1 | V2023.01 |
| Verification possible even without identical hardware | FX3-CPUx V2.00.0 (Step 2.xx) | V1.3.0 | V1.6.x |
| Status input data and status output data in logic | FX3-CPUx V2.00.0 (Step 2.xx) and FX3-XTIO, FX3-XTDI, or FX3-XTDS, each V2.00.0 (Step 2.xx) | V1.3.0 | V1.6.x |
| Easy applications for FX3-MOC0 | FX3-MOC0 V1.10.0 | V1.7.1 | N. a. |
| Special functions | | | |
| Two S3000 safety laser scanners on one EFI interface | FX3-CPU1 V1.00.0 | V1.2.2 | N. a. |
| Flexi Link | FX3-CPU1 V2.00.0 (Step 2.xx) | V1.3.0 | N. a. |
| Flexi Loop | FX3-CPUx V3.00.0 (Step 3.xx) and FX3-XTIO, FX3-XTDI, or FX3-XTDS, each V3.00.0 (Step 3.xx) | V1.6.0 | V1.8.0 |
| Flexi Line | FX3-CPU3 V3.00.0 (Step 3.xx) | V1.6.0 | N. a. |
| Automatic configuration of connected EFI-enabled safety sensors (automatic configuration recovery) | FX3-CPU2 V3.00.0 (Step 3.xx) | V1.5.0 (FX3-CPU2) V1.6.0 (FX3-CPU3) | N. a. |
| Deactivation of test signals Q1 to Q4 on the FX3-XTIO possible | FX3-XTIO V2.00.0 (Step 2.xx) | V1.3.0 | V1.6.x |
| Fast shut-off with bypass at FX3-XTIO | FX3-CPUx and FX3-XTIO, each V2.00.0 (Step 2.xx) | V1.3.0 | V1.6.x |
| Multiple safety mats at FX3-XTIO/FX3-XTDI | FX3-XTIO or FX3-XTDI, each V1.13.0 | V1.3.0 | V1.6.x |
| Data recorder | FX3-CPUx V2.00.0 (Step 2.xx) | V1.5.0 | V1.6.x |
| Extended cross-circuit detection time for the switching of increased capacitive loads at FX3-XTIO | FX3-XTIO V3.00.0 (Step 3.xx) | V1.6.0 | V1.6.x |
| Configurable filter time for in/out filters and out/in filters at inputs I1 to I8 at FX3-XTIO/FX3-XTDI/FX3-XTDS | FX3-XTIO, FX3-XTDI, or FX3-XTDS, each V3.00.0 (Step 3.xx) | V1.6.0 | V1.6.x |
| Optimization of logic execution time | FX3-CPUx V4.00.0 (Step 4.xx) | V1.7.1 | V1.6.x |
| Automated download | No limitation | V1.9.1 | n.a. |

3 PRODUCT DESCRIPTION

| | Necessary module with firmware from version | Available from Flexi Soft Designer | Available from Safety Designer |
|--|---|------------------------------------|--------------------------------|
| Checksums for logic pages and user-defined function blocks | No limitation | V1.9.3 | n.a. |
| Licensed SICK safety systems | FX3-CPUx V4.00.0 (Step 4.xx) | V1.9.4 | n.a. |
| Devices | | | |
| FX3-CPU0 | No limitation | V1.2.0 | V1.6.x |
| FX3-CPU1 | No limitation | V1.2.0 | N. a. |
| FX3-CPU2 | No limitation | V1.2.0 | N. a. |
| FX3-CPU3 | No limitation | V1.2.0 | N. a. |
| FX3-XTIO | No limitation | V1.2.0 | V1.6.x |
| FX3-XTDI | No limitation | V1.2.0 | V1.6.x |
| Gateways for PROFINET IO, Modbus® TCP and EtherNet/IP™ | FX3-CPUx V1.11.0 (Step 1.xx) | V1.2.0 | V1.6.x |
| CC-Link gateway | FX3-CPUx V1.11.0 (Step 1.xx) | V1.3.0 | N. a. |
| CANopen gateway | FX3-CPUx V1.11.0 (Step 1.xx) | V1.3.0 | V1.6.x |
| EtherCAT gateway | FX3-CPUx V2.00.0 (Step 2.xx) | V1.3.0 | V1.6.x |
| EFI-pro gateway | FX3-CPU0 V4.00.0 (Step 4.xx) | N. a. | V1.6.x |
| SIM1000 FXG ²⁾ | FX3-CPUx V1.11.0 (Step 1.xx) | V1.9.2 | n.a. |
| Speed Monitor MOC3SA | Unrestricted | V1.3.0 | V1.6.x |
| FX3-MOC0 | FX3-CPUx V2.50.0 | V1.5.0 | N. a. |
| FX3-MOC1 | FX3-CPUx V2.50.0 | V1.8.0 | V1.6.x |
| FX3-XTDS | Unrestricted | V1.6.0 | V1.6.x |
| FX0-STIO | Unrestricted | V1.6.0 | V1.6.x |
| FX3-ANAO | FX3-CPUx V4.00.0 (Step 4.xx) | V1.8.0 | V1.7.0 |
| Conformities | | | |
| RoHS conformity FX3-XTIO | FX3-XTIO V1.01.0 | - | - |

1) N. a. = Not available

2) All other modules as from market introduction.

2) You can find information on this gateway in the SIM1000 FXG operating instructions.

**NOTE**

- More recent modules are backward compatible so that each module can be replaced by one with a higher firmware version.
- Flexi Soft Designer Version \geq V1.4.0 can also be used to configure devices with a later version of the firmware, even if Flexi Soft Designer does not yet recognize the new firmware. In such cases, the user will only be able to access the function packages (Step 1.xx, Step 2.xx, Step 3.xx, or Step 4.xx) that are supported by the available version of Flexi Soft Designer.
- A corresponding new version of the configuration software is needed in order to use the full functional scope of modules with a later firmware version.
- The configuration software is not upwards-compatible. In other words, a project created with a more recent version of the configuration software cannot be opened with an older version.
- The function package (Step 1.xx, Step 2.xx, Step 3.xx, or Step 4.xx) must be selected in the hardware configuration menu of the configuration software. The availability of a desired function package in the configuration software can be found in the table.
- To use the Step N.xx function package, the relevant module must have a minimum firmware version of VN.00.0. If you try to transfer a configuration in a module with a lower firmware version, an error message is displayed.
- The hardware version of the Flexi Soft modules can be seen in the hardware configuration of the configuration software in online status or in the report if the system was previously online.
- You will find the **firmware version** of the Flexi Soft modules on the type label of the Flexi Soft modules in the firmware version field.
- The date of manufacture of a device can be found in the S/N field on the type label in the format yywwnnnn (yy = year, ww = calendar week, nnnn = sequential serial number in the calendar week).
- The version of the configuration software can be found by selecting **Info** in the **Extras** menu.
- The latest version of the configuration software can be found on the Internet at www.sick.com.

3.3 Construction and function

System construction

A Flexi Soft system consists of the following modules:

- 1 Flexi Soft system plug
- 1 Flexi Soft main module
- Up to 2 Flexi Soft gateways
- Up to 12 Flexi Soft expansion modules or up to 6 motion control modules³⁾
- In addition, up to 8 UE410-2R0 relay modules and/or up to 4 UE410-4R0 relay modules (i.e., a maximum of 16 safe relay outputs)

**NOTE**

Only those modules listed here can be connected to a Flexi Soft system; other modules are not permitted.

³⁾ The number of expansion modules is limited by the capacity of the FLEXBUS+ backplane bus. A motion control module (FX3-MOCx) requires twice the bus capacity of the other expansion modules. Therefore, each FX3-MOCx reduces the maximum possible number of expansion modules that can be used by two.

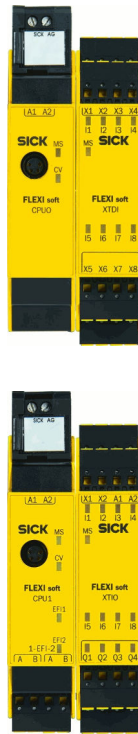

Figure 1: Example minimum construction of the Flexi Soft system with FX3-CPU0 and FX3-XTDI or FX3-CPU1 and FX3-XTIO

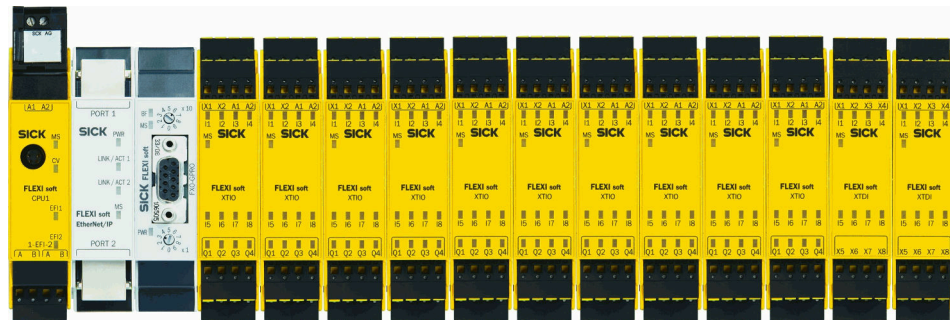

Figure 2: Maximum structure of the Flexi Soft system (without relay modules)

Table 4: Overview of modules

| Model | Type | Inputs | Outputs | Function blocks | Max. number |
|--------------------------|---|-------------------|-------------------|-----------------|-----------------|
| Main modules | | | | | |
| FX3-CPU0 | Main module | - | - | 255 | 1 |
| FX3-CPU1 | Main module with EFI | 4 ¹⁾ | - | | |
| FX3-CPU2 | Main module with EFI and ACR | 4 ¹⁾ | - | | |
| FX3-CPU3 | Main module with EFI and ACR and Flexi Line | 8 ²⁾ | - | | |
| Gateways | | | | | |
| FX0-GENT | EtherNet/IP™ gateway | 2 ³⁾ | - | - | 2 |
| FX0-GMOD | Modbus TCP gateway | 2 ³⁾ | - | - | |
| FX0-GPNT | PROFINET IO gateway | 2 ³⁾ | - | - | |
| FX0-GETC | EtherCAT gateway | 2 ³⁾ | - | - | |
| FX0-GPRO | PROFIBUS DP gateway | 1 ⁴⁾ | - | - | |
| FX0-GCAN | CANopen gateway | 1 ⁴⁾ | - | - | |
| FX0-GDEV | DeviceNet gateway | 1 ⁴⁾ | - | - | |
| FX3-GEPR | EFI-pro gateway | 2 ³⁾ | - | - | 1 |
| Expansion modules | | | | | |
| FX3-XTIO | I/O module | 8 | 4 | - | 12 |
| FX3-XTDI | I/O module | 8 | - | - | |
| FX3-XTDS | I/O module | 8 | 4-6 ⁵⁾ | - | |
| FX0-STIO | I/O module | 6-8 ⁶⁾ | 6-8 ⁶⁾ | - | |
| FX3-ANAO | Analog input module | 2 ⁷⁾ | - | - | |
| FX3-MOCO | Motion control | - | - | 10 | 6 ⁸⁾ |
| FX3-MOC1 | Motion control | - | - | 25 | |
| Relay modules | | | | | |
| UE410-2RO | Relay module | - | 2 | - | 8 ⁹⁾ |
| UE410-4RO | Relay module | - | 4 | - | 4 ⁹⁾ |

- 1) EFI connections.
- 2) EFI and Flexi Line connections.
- 3) RJ-45 female connectors.
- 4) RS-485 female connector.
- 5) Non-safe outputs. Test outputs XY1 and XY2 can be used as additional non-safe outputs.
- 6) The FX0-STIO features 6 non-safe inputs and 6 non-safe outputs. In addition, connections IY7 and IY8 can be used as non-safe inputs as well as non-safe outputs.
- 7) Each FX3-ANAO expansion module provides two analog inputs, which are combined to form one safe channel. An FX3-ANAO can therefore safely detect the size of an analog process using two sensors.
- 8) Each FX3-MOCx module reduces the maximum possible number of expansion modules that can be used by two.
- 9) Maximum 16 safe relay outputs.

3.4 Modules

3.4.1 FX3-CPU0 main module

Overview

The FX3-CPU0 main module is the CPU for the entire system. It is where all signals are monitored and their logic is processed on the basis of the configuration stored in the system plug. The system outputs are switched further to the processing of the signals. The FLEXBUS+ internal bus provides the data interface.

Prerequisites

- The main module can only be operated together with the FX3-MPLO system plug.

FX3-CPU0 main module

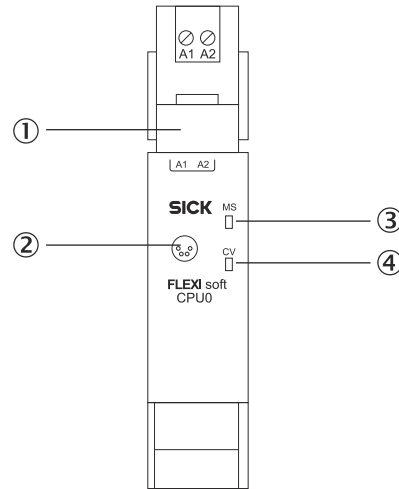

Figure 3: FX3-CPU0 main module

- ① FX3-MPLO system plug
- ② RS-232 interface
- ③ MS LED (Module Status)
- ④ CV LED (Configuration Verified)

3.4.2 FX3-CPU1 main module

Overview

The functions of the FX3-CPU1 main module are the same as those of the FX3-CPU0 main module.

Additionally, this module has 2 EFI interfaces. When EFI-enabled devices are connected, the following functions are supported:

- Transfer configuration to the connected EFI-enabled devices
- Import configuration from the connected EFI-enabled devices
- Diagnose the connected EFI-enabled devices
- Exchange process data between main module and EFI-enabled devices
- Connect up to four FX3-CPU1 main modules to form a Flexi-Link system

Prerequisites

- The main module can only be operated together with the FX3-MPLO system plug.

FX3-CPU1 main module

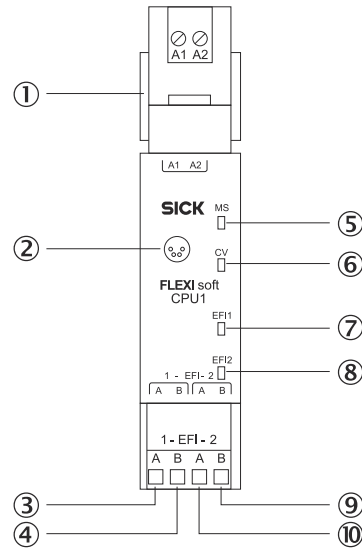

Figure 4: FX3-CPU1 main module

- ① FX3-MPL0 system plug
- ② RS-232 interface
- ③ EF1_A
- ④ EF1_B
- ⑤ MS LED (Module Status)
- ⑥ CV LED (Configuration Verified)
- ⑦ EF1 LED
- ⑧ EF2 LED
- ⑨ EF2_B
- ⑩ EF2_A

Further topics

- ["Flexi Line", page 46](#)
- ["Enhanced Function Interface \(EFI\)", page 44](#)

3.4.3 FX3-CPU2 main module

Overview

The functions of the FX3-CPU2 main module are the same as those of the FX3-CPU1 main module.

In addition, the FX3-CPU2 main module has a function for automatic configuration of connected EFI-capable devices (ACR).

Prerequisites

- The main module can only be operated together with the FX3-MPL1 system plug.

FX3-CPU2 main module

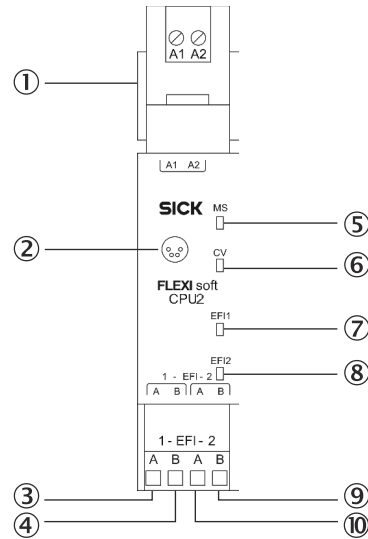

Figure 5: FX3-CPU2 main module

- ① FX3-MPL1 system plug
- ② RS-232 interface
- ③ EFI1_A
- ④ EFI1_B
- ⑤ MS LED (Module Status)
- ⑥ CV LED (Configuration Verified)
- ⑦ EFI1 LED
- ⑧ EFI2 LED
- ⑨ EFI2_B
- ⑩ EFI2_A

Further topics

- ACR: "[Automatic configuration recovery \(ACR\)](#)", page 47 and “Flexi Soft in Flexi Soft Designer configuration software” operating instructions.

3.4.4 FX3-CPU3 main module

Overview

The functions of the FX3-CPU3 main module are the same as those of the FX3-CPU2 main module.

This module also has a Flexi Line interface to support the safe networking of up to 32 Flexi Soft stations.

Prerequisites

- The main module can only be operated together with the FX3-MPL1 system plug.

FX3-CPU3 main module

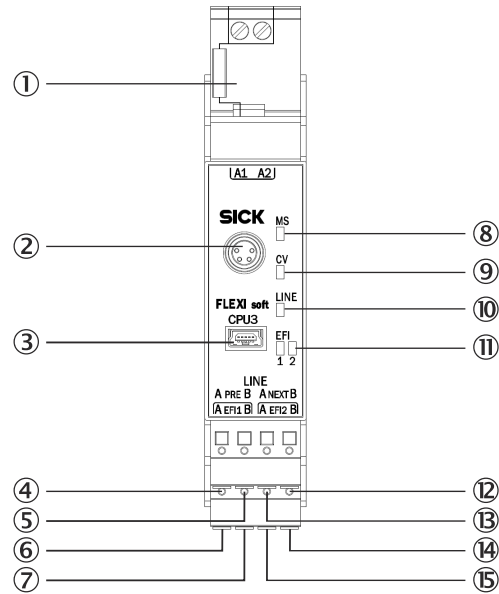

Figure 6: FX3-CPU3 main module

- ① FX3-MPL1 system plug
- ② RS-232 interface
- ③ USB interface
- ④ Line_PRE_A (previous)
- ⑤ Line_PRE_B (previous)
- ⑥ EF1_A
- ⑦ EF1_B
- ⑧ MS LED (Module Status)
- ⑨ CV LED (Configuration Verified)
- ⑩ LINE LED
- ⑪ EF1 and EF2 LEDs
- ⑫ Line_NEXT_B (next)
- ⑬ Line_NEXT_A (next)
- ⑭ EF2_B
- ⑮ EF2_A

Further topics

- ["Flexi Line", page 46](#)
- ["USB", page 43](#)

3.4.5 FX3-MPL0 and FX3-MPL1 system plugs

Overview

There is a system plug at each main module. The system configuration for the entire Flexi Soft system is stored only in the system plug. This is beneficial when replacing modules, because it means that a full reconfiguration of the Flexi Soft system is not required.

System plug variants

Table 5: System plug variants

| System plug | Terminal color | Compatible main modules | Functions |
|-------------|----------------|--|--|
| FX3-MPLO | Black | <ul style="list-style-type: none"> FX3-CPU0 FX3-CPU1 | <ul style="list-style-type: none"> Flexi Soft system power supply Storage of system configuration (without EFI-enabled devices) |
| FX3-MPL1 | Yellow | <ul style="list-style-type: none"> FX3-CPU2 FX3-CPU3 | <ul style="list-style-type: none"> Flexi Soft system power supply Storage of system configuration (with EFI-enabled devices) Automated configuration of connected EFI-capable safety sensors (automated configuration recovery) |

Complementary information

- The main module, the internal logic of all expansion modules and gateways on the FLEXBUS+ as well as their inputs (I1 ... I8) and test outputs (X1 to X8 as well as XY1 and XY2) are supplied electrically only via the system plug. The outputs are supplied separately, however (Q1 to Q4, Y1 to Y6 as well as IY7 and IY8).
- The data stored in the system plug is also retained in the event of any interruption in the voltage supply.
- Clearly and unambiguously mark all connections (connecting cables and plug connectors) on the safety controller to avoid mix-ups. The Flexi Soft system features several connections of the same design. Therefore, you must make sure that no unplugged connecting cables or plug connectors are accidentally connected to the wrong connection point.

3.4.6 FX3-XTIO I/O module

Overview

The FX3-XTIO module is an input/output expansion module with 8 safety inputs and 4 safety outputs. It has 2 test pulse generators, one for test output X1 and one for test output X2.

The FX3-XTIO module supports the following functions:

- Monitoring of the connected safety devices
- Forwarding of information at inputs I1 to I8 to the main module
- Receipt of control signals from the main module and corresponding switching of outputs
- Fast shut-off: direct shutdown of the actuators connected to the module. This reduces the response time of the overall system. The response times of the devices at the inputs and outputs are extended by 8 ms in order to shut down the outputs. Run times on the FLEXBUS+ internal bus and the logic processing time are not relevant in this case.
- Activation or deactivation of the test signals at outputs Q1 to Q4

Important information



WARNING

Ineffectiveness of the protective device due to undetected short-circuits between the test pulse generators

The dangerous state may not be stopped or not be stopped in a timely manner in the event of non-compliance.

- ▶ Configure the test outputs of the Flexi Soft expansion modules with test pulse widths ≤ 4 ms and a test pulse interval ≥ 200 ms.

Prerequisites

- The module can only be operated with a main module.

I/O module FX3-XTIO

The voltage supply for the internal logic and the test outputs is provided via the system plug and the internal FLEXBUS+ bus.

The voltage supply of outputs Q1 to Q4 of the FX3-XTIO must be provided directly via A1 / A2 on the respective module.

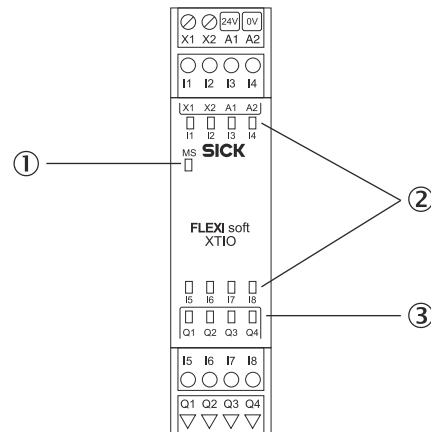

Figure 7: I/O module FX3-XTIO

- ① MS LED (Module Status)
- ② 8 input LEDs
- ③ 4 output LEDs

Further topics

- ["Construction and function", page 17](#)
- ["Connection of devices", page 78](#)
- ["Maximum response time of the Flexi Soft system", page 132](#)

3.4.6.1 Internal circuitry

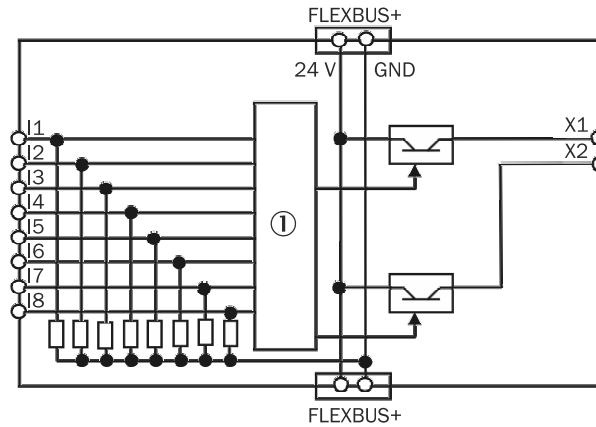

Figure 8: Internal structure of the FX3-XTIO – safety inputs and test outputs

① Internal logic

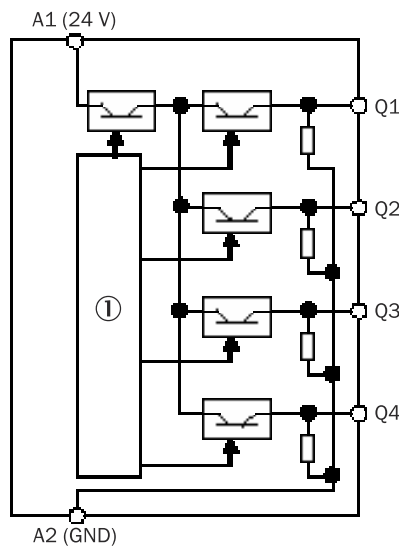

Figure 9: Internal structure of the FX3-XTIO – safety outputs

① Internal logic

3.4.6.2 Deactivation of test signals at outputs Q1 to Q4 on the FX3-XTIO

With the FX3-XTIO Step $\geq 2.xx$ (firmware versions V2.00.0), it is possible to deactivate the test pulses at one or more outputs of FX3-XTIO modules.

Deactivating the test pulses at one or more of the outputs (Q1 to Q4) of an FX3-XTIO module reduces the safety parameters of all the outputs (Q1 to Q4) of the module concerned. If the test pulses are deactivated, a short-circuit cannot be recognized after 24 V if the output is high. Therefore, in the case of a recognized internal hardware error, the switch-off capability of the other outputs can be impaired by the reverse current of 24 V via the output whose test pulse has been deactivated. This must be taken into account to ensure that the application is in line with an appropriate risk analysis and risk avoidance strategy.



WARNING

Reduced safety parameters by deactivating test pulses

The target safety-related level may not be achieved in the event of non-compliance.

If the test pulse is deactivated at one or several of safety outputs Q1 to Q4, take the following measures:

- ▶ Use protected or separate cabling.
- ▶ At least once a year, either switch off all outputs without test pulses simultaneously for at least one second using the logic program of the main module or restart the Flexi Soft system by switching off the voltage supply.

3.4.6.3 Extended error detection time for cross-circuits at outputs Q1 to Q4 on the FX3-XTIO for the switching of increased capacitive loads



WARNING

Extended error recognition time due to switching of higher capacitive loads

The target safety-related level may not be achieved in the event of non-compliance.

- ▶ Pay attention to the extended error recognition time.

With the FX3-XTIO Step $\geq 3.xx$ (firmware version V3.00.0), it is possible to configure an extended fault detection time for cross-circuits that affect outputs Q1 to Q4 of FX3-XTIO modules.

This may be necessary to switch loads where the voltage at the load does not drop to the Low level as quickly as expected, with the result that if the standard error detection time is set, a cross-circuit error occurs immediately after switching off (change from High to Low). Examples of such instances include:

- Loads with a capacitance that is higher than the standard level permitted for the output, such as the supply voltage of PLC output cards that require safety-related switching.
For this application, the test signal for the input must also be deactivated (see ["Deactivation of test signals at outputs Q1 to Q4 on the FX3-XTIO", page 26](#)). Safety-capable inputs on fail-safe PLCs generally also have capacitance at the inputs.
- Inductive loads which cause an overshoot in the positive voltage range after the induction voltage has died down.

Table 6: Maximum permissible time until Low level is reached after output (Q1 to Q4) is deactivated

| FX3-XTIO firmware version | Switching of increased capacitive loads | Maximum permissible time until Low level (≤ 3.5 V) is reached after output (Q1 to Q4) is deactivated |
|---------------------------|---|--|
| \leq V2.11.0 | Not possible | 3 ms |
| \geq V3.00.0 | Deactivated | 3 ms |
| | Activated | 43 ms |

Once the output has been deactivated, the capacitance that exceeds the standard value permitted for the output must be discharged by the user until the Low level is reached. If this condition is not met within the maximum permissible time, it results in a cross-circuit fault at the corresponding output regardless of whether test pulses are activated or deactivated for the output concerned.



WARNING

Loss or impairment of the safety-related switch-off capability due to PLC output card errors

The dangerous state may not be stopped or not be stopped in a timely manner in the event of non-compliance.

- ▶ Use a PLC output card that is suitable for safety-related deactivation of the outputs by means of supply voltage switching.
- ▶ Take suitable measures to prevent a cross-circuit, e.g., using protected cable laying.
- ▶ When using a buffer capacitor in the voltage supply of the PLC output card, observe the possibly extended response time.

For information about this, see also the “Flexi Soft in the Flexi Soft Designer Configuration Software” and “Flexi Soft in the Safety Designer Configuration Software” operating instructions.

3.4.6.4 Fault detection time and fault response time when using single-channel outputs on the FX3-XTIO

The fault detection time plus the fault response time of the FX3-XTIO depends on the configuration of the respective output.

In the case of an internal hardware fault, outputs (Q1 to Q4), which would normally be on low, may switch off with a delay and/or may briefly switch to high until the fault has been recognized and the fault reaction has been carried out.



WARNING

Ineffectiveness of the protective device due to brief switching to high for single-channel outputs

The dangerous state may not be stopped or not be stopped in a timely manner in the event of non-compliance.

The target safety-related level may not be achieved in the event of non-compliance.

- ▶ For risk analysis and risk avoidance strategy, consider the following:
 - Brief switching to high or delayed switching off of single-channel outputs
 - Fault detection time and fault response time

Table 7: Fault detection time and fault response time on the FX3-XTIO

| FX3-XTIO firmware version | Switching higher capacitive loads | Fault detection time + fault response time |
|---------------------------|-----------------------------------|--|
| ≤ V2.11.0 | Not possible | ≤ 10 ms |
| ≥ V3.00.0 | Deactivated | ≤ 10 ms |
| | Enabled | ≤ 50 ms |

3.4.7 FX3-XTDI I/O module

Overview

The FX3-XTDI module is an input expansion module with 8 safety inputs. It has 2 test pulse generators, one for test outputs X1, X3, X5 and X7 and one for test outputs X2, X4, X6 and X8.

The FX3-XTDI module supports the following functions:

- Monitoring of the connected safety devices
- Forwarding of information at inputs I1 to I8 to the main module

Important information



WARNING

Ineffectiveness of the protective device due to undetected short-circuits between the test pulse generators

The dangerous state may not be stopped or not be stopped in a timely manner in the event of non-compliance.

- ▶ Rule out short-circuits between the odd-numbered test outputs X1, X3, X5 and X7 through suitable wiring (e.g. separate routing, protected cables).
- ▶ Rule out short-circuits between the even-numbered test outputs X2, X4, X6 and X8 through suitable wiring (e.g. separate routing, protected cables).
- ▶ Configure the test outputs of the Flexi Soft expansion modules with test pulse widths ≤ 4 ms and a test pulse interval ≥ 200 ms.

Prerequisites

- The module can only be operated with a main module.

I/O module FX3-XTDI

The voltage supply for the internal logic and the test outputs is provided via the system plug and the internal FLEXBUS+ bus.

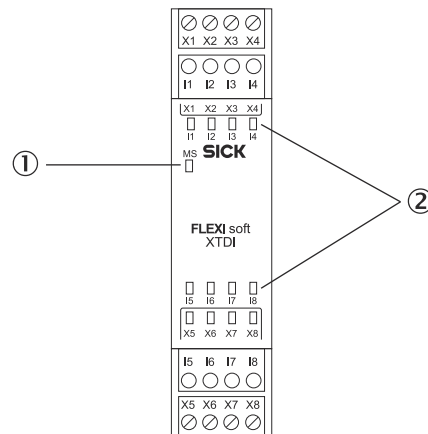

Figure 10: I/O module FX3-XTDI

- ① MS LED (Module Status)
- ② 8 input LEDs

Further topics

- ["Construction and function", page 17](#)
- ["Connection of devices", page 78](#)

3.4.7.1 Internal circuitry

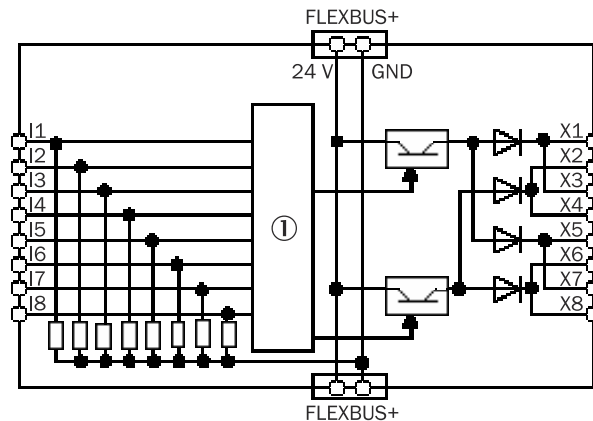

Figure 11: Internal structure of the FX3-XTDI – safety inputs and test outputs

① Internal logic

3.4.8 FX3-XTDS I/O module

Overview

The FX3-XTDS module is an input/output expansion module with 8 safety inputs and 4 non-safety outputs. It has 2 test pulse generators, one for test output XY1 and one for test output XY2.

The FX3-XTDS module supports the following functions:

- Monitoring of the connected safety devices
- Forwarding of information at inputs I1 to I8 to the main module
- Receipt of control signals from the main module and corresponding switching of outputs
- Outputs XY1 and XY2 can be used as either test outputs or non-safe outputs.

Important information



WARNING

Improper use of the non-safety outputs

The dangerous state may not be stopped or not be stopped in a timely manner in the event of non-compliance.

- ▶ Do not use the FX3-XTDS outputs for safety functions.



WARNING

Ineffectiveness of the protective device due to undetected short-circuits between the test pulse generators

The dangerous state may not be stopped or not be stopped in a timely manner in the event of non-compliance.

- ▶ Configure the test outputs of the Flexi Soft expansion modules with test pulse widths ≤ 4 ms and a test pulse interval ≥ 200 ms.



NOTE

If both outputs XY1 and XY2 are used as non-safety outputs, then it is nevertheless possible to connect a tested element to one of these inputs I1 to I8. However, this element is marked red in the hardware configuration as a warning.

Prerequisites

- The module can only be operated with a main module.

I/O module FX3-XTDS

The voltage supply for the internal logic and the test outputs is provided via the system plug and the internal FLEXBUS+ bus.

The voltage supply of the outputs Y3 to Y6 of the FX3-XTDS must be provided directly via A1 / A2 on the respective module.

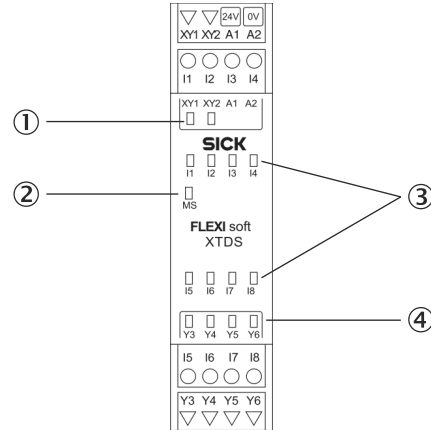

Figure 12: I/O module FX3-XTDS

- ① 2 LEDs for test outputs or non-safe outputs
- ② MS LED (Module Status)
- ③ 8 input LEDs
- ④ 4 output LEDs

Further topics

- ["Construction and function", page 17](#)

3.4.8.1 Internal circuitry

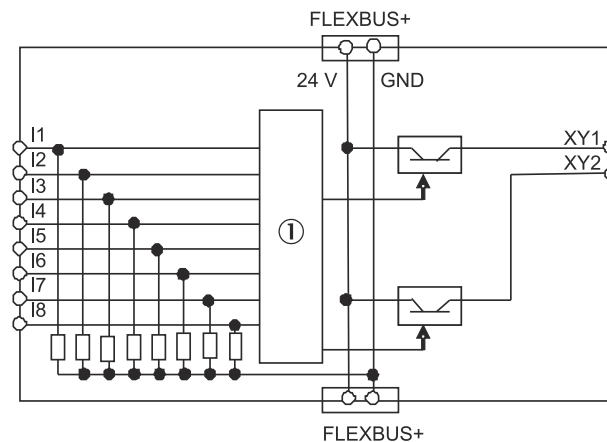

Figure 13: Internal structure of the FX3-XTDS – safety inputs and test outputs

- ① Internal logic

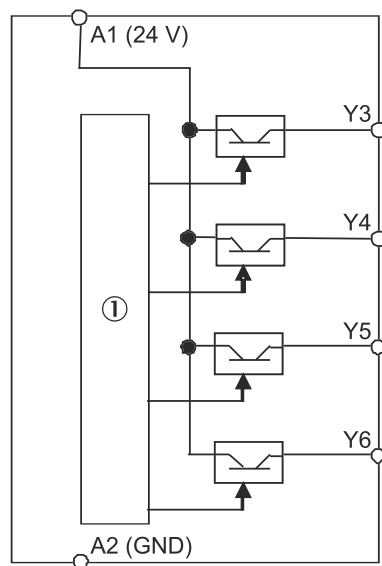

Figure 14: Internal structure of the FX3-XTDS – non-safe outputs

① Internal logic

3.4.9 FX0-STIO I/O module

Overview

The FX0-STIO module is an expansion module with 6 non-safe inputs, 6 non-safe outputs, and 2 connections that can be used as either non-safe inputs or non-safe outputs.

The FX0-STIO module supports the following functions:

- Forwarding of information at inputs I1 to I6 to the main module
- Receipt of control signals from the main module and corresponding switching of outputs

Important information



WARNING

Improper use of the non-safe modules

The dangerous state may not be stopped or not be stopped in a timely manner in the event of non-compliance.

The target safety-related level may not be achieved in the event of non-compliance.

- ▶ Do not use the FX0-STIO for safety-related functions.

Prerequisites

- The module can only be operated with a main module.

I/O module FX0-STIO

The internal logic is supplied with voltage via the system plug and the internal FLEX-BUS+ bus.

The voltage supply of the outputs Y1 to Y6 and the IY7 and IY8 connections of the FX0-STIO must be provided directly via A1 / A2 on the respective module.

The IY7 and IY8 connections on a FX0-STIO module can be used either as non-safety inputs or non-safety outputs.

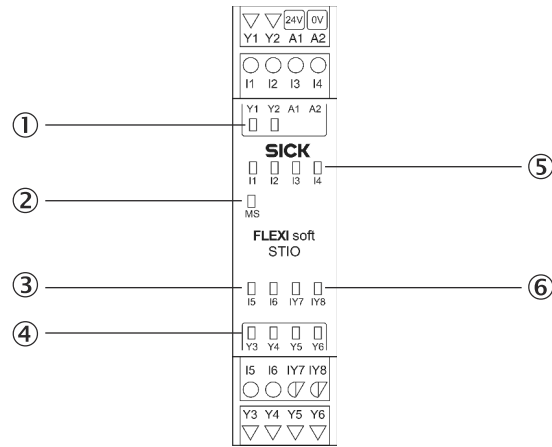

Figure 15: I/O module FX0-STIO

- ① 2 output LEDs
- ② MS LED (Module Status)
- ③ 2 input LEDs
- ④ 4 output LEDs
- ⑤ 4 input LEDs
- ⑥ 2 LEDs for configurable inputs or outputs

Further topics

- ["Construction and function", page 17](#)

3.4.9.1 Internal circuitry

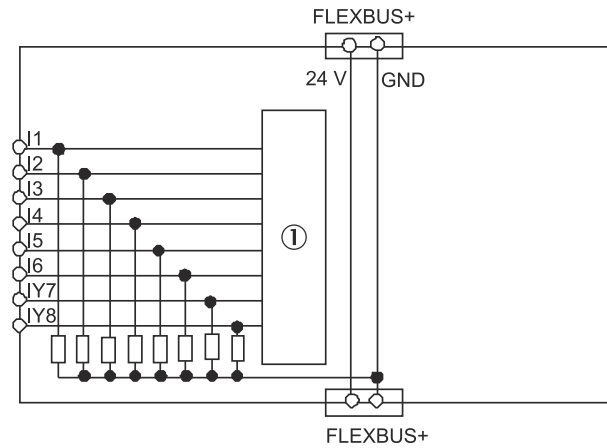

Figure 16: Internal structure of the FX0-STIO - non-safe inputs

- ① Internal logic

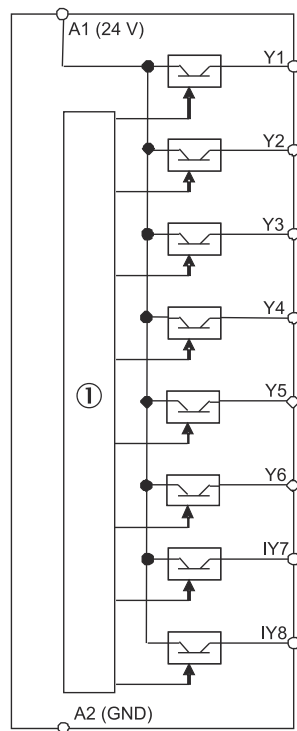

Figure 17: Internal structure of the FX0-STIO – non-safe outputs

① Internal logic

3.4.10 Motion Control FX3-MOCO

Overview

The FX3-MOCO motion control module is an expansion module for the safe movement monitoring of drive systems. In this context, movement means the speed level, speed ramp and standstill position. The module has an interface to connect two encoders (e.g. A/B incremental encoders, linear encoders, motor feedback systems or linear distance measurement systems).

FX3-MOCO supports the following functions:

- Connection of two encoders for one or two axes
 - A/B incremental encoder HTL 24 V, HTL 12 V, TTL, max. 300 kHz
 - A/B incremental encoder RS-422, max. 1 MHz ⁴⁾
 - Sine/cosine encoder 1 V_{SS}, max. 120 kHz
 - SSI encoder, RS-422, max. 1 Mbaud
- Standstill monitoring
- Speed monitoring
- Direction monitoring
- Processing of information from the encoders and control signals from the main module in the internal logic of the FX3-MOCO. A dedicated logic editor with a number of function blocks is available for this purpose.
- Forwarding of information from the internal logic to the main module

Prerequisites

- The module can only be operated with a main module with the following firmware version:
 - FX3-CPU0 and FX3-CPU1: ≥ V2.50.0
 - All other FX3 CPUx modules: All firmware versions

⁴⁾ Only possible for encoder 1 (ENC1)

Motion Control FX3-MOCO

The power supply to the internal logic is provided via the system plug and the FLEX-BUS+ internal bus.

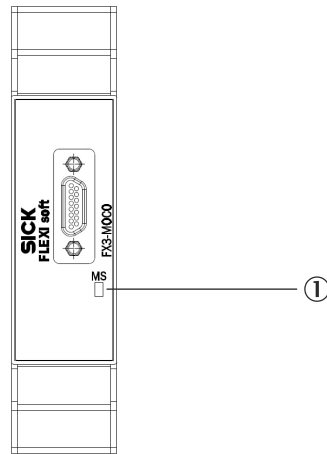

Figure 18: Motion Control FX3-MOCO

① MS LED (Module Status)

Encoder selection



WARNING

Ineffectiveness of the protective device due to selection of an unsuitable encoder
The target safety-related level may not be achieved in the event of non-compliance.

- ▶ Select a suitable encoder.
- ▶ Take suitable measures against the encoder’s systematic errors and common causes of error.

Choosing the right encoder is crucial to achieving the desired safety integrity level (SIL) and performance level (PL). Systematic faults and common cause faults (CCF), in particular, need to be minimized in this case.

Table 8: Achievable SIL and PL

| Use of encoders | Possible axes per FX3-MOCO | Achievable SIL (IEC 61508, IEC 62061), PL (ISO 13849-1) ¹⁾ | Available functions for detecting encoder errors |
|--|----------------------------|---|--|
| One sine-cosine safety encoder (e.g., DFS60S Pro) | 2 | SIL2, PL d | <ul style="list-style-type: none"> • Sine-cosine analog voltage monitoring ²⁾ • Monitoring of the ID code of the encoder/ motor feedback connection box in order to detect a break in the FX3-MOCO connection cable ³⁾ |
| Two encoders with relative position, chosen from the following: <ul style="list-style-type: none"> • A/B • Sine-cosine • SSI They can be the same type or different types | 1 | SIL3, PL e | <ul style="list-style-type: none"> • Speed comparison function block ⁴⁾ • Monitoring of the ID code of the encoder/ motor feedback connection box in order to detect a break in the FX3-MOCO connection cable ³⁾ |

1) Actual values: see table 163, page 156.

2) Can be configured for sine-cosine encoders in the hardware configuration of the configuration software.

3) Can be used by any type of encoder supported in the hardware configuration of the configuration software.

4) Can be used in the FX3-MOCO logic. For detailed information, see the “Flexi Soft in the Flexi Soft Designer Configuration Software” operating instructions.

Complementary information

The sine/cosine signals of a HIPERFACE® interface can also be connected to the encoder connection of the FX3-MOC1. In this way, the HIPERFACE® interface can be used like a sine/cosine encoder.

Other HIPERFACE® functions cannot be used.

Further topics

- ["Construction and function", page 17](#)
- ["Measures against common causes of error", page 127](#)

3.4.11 Motion Control FX3-MOC1

Overview

The FX3-MOC1 motion control module is an expansion module for the safe movement monitoring of drive systems. In this context, movement means speed level, speed ramp and position. The module has an interface to connect two encoders (e.g. A/B incremental encoders, linear encoders, motor feedback systems or linear distance measurement systems).

The FX3-MOC1 offers the following functions:

- Connection of two encoders for one or two axes
 - A/B incremental encoder HTL 24 V, HTL 12 V, TTL, max. 300 kHz
 - A/B incremental encoder RS-422, max. 1 MHz ⁵⁾
 - Sine/cosine encoder 1 V_{SS}, max. 120 kHz
 - SSI encoder, RS-422, max. 1 MBaud
- Position monitoring
- Standstill monitoring
- Speed monitoring
- Speed cross check
- Direction monitoring
- Processing of information from the encoders and control signals from the main module in the internal logic of the FX3-MOC1. A dedicated logic editor with a number of function blocks is available for this purpose.
- Forwarding of information from the internal logic to the main module

Prerequisites

- The module can only be operated with a main module with the following firmware version:
 - FX3-CPU0 and FX3-CPU1: ≥ V2.50.0
 - All other FX3 CPUx modules: All firmware versions

Motion Control FX3-MOC1

The internal logic is supplied with voltage via the system plug and the internal FLEX-BUS+ bus.

⁵⁾ Only possible for encoder 1 (ENC1)

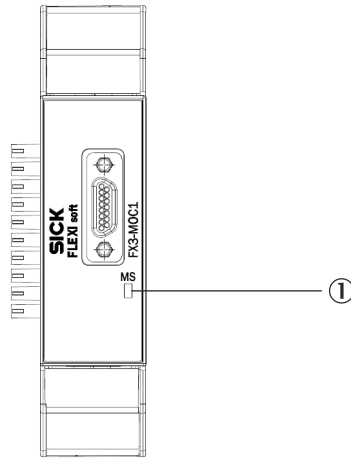

Figure 19: Motion Control FX3-MOC1

① MS LED (module status)

Encoder selection



WARNING

Ineffectiveness of the protective device due to selection of an unsuitable encoder
The target safety-related level may not be achieved in the event of non-compliance.

- ▶ Select a suitable encoder.
- ▶ Take suitable measures against the encoder’s systematic errors and common causes of error.

Choosing the right encoder is crucial to achieving the desired safety integrity level (SIL) and performance level (PL). Systematic errors and common cause errors (CCF), in particular, need to be minimized in this case.

Table 9: Achievable SIL and PL

| Use of encoders | Possible axes per FX3-MOC1 | Achievable SIL (IEC 61508, IEC 62061), PL (ISO 13849-1) ¹⁾ | Available functions for the detection of encoder errors |
|---|----------------------------|---|---|
| A sine/cosine safety encoder (e.g. DFS60S Pro) | 2 | SIL2, PL d for speed monitoring (including direction and standstill monitoring) | <ul style="list-style-type: none"> • Sine/cosine analog voltage monitoring ²⁾ • ID code monitoring of the encoder connection unit to detect a break in the FX3-MOC1 connecting cable ³⁾ (possible, but not required, as the sine/cosine analog voltage monitoring can detect a break in the connecting cable) |
| A sine/cosine safety encoder (e.g. DFS60S Pro) with <ul style="list-style-type: none"> • Safe reference cam (i.e. with corresponding SIL or PL) • Position by Reference function block • Reference run after restart | 2 | SIL2, PL d for position monitoring (including speed, direction and standstill monitoring) | |

| Use of encoders | Possible axes per FX3-MOC1 | Achievable SIL (IEC 61508, IEC 62061), PL (ISO 13849-1) ¹⁾ | Available functions for the detection of encoder errors |
|---|----------------------------|---|---|
| <p>Two encoders with relative position, optionally</p> <ul style="list-style-type: none"> • A/B • Sine/cosine • SSI <p>Same or different types</p> | 1 | SIL3, PL e for speed monitoring (including direction and standstill monitoring) | <ul style="list-style-type: none"> • Speed comparison function block ⁴⁾ • Position comparison function block ⁴⁾ • Monitoring of the ID identifier of the encoder/motor feedback connection unit for detecting a break in the FX3-MOC1 connecting cable ³⁾ |
| <p>A safety encoder with absolute position with</p> <ul style="list-style-type: none"> • SSI + Sin/Cos <p>With</p> <ul style="list-style-type: none"> • Initial referencing during commissioning • Position by Reference with Memory Function function block | 1 | SIL3, PL e for position monitoring (including speed, direction and standstill monitoring) | <ul style="list-style-type: none"> • Position comparison function block ⁴⁾ • Monitoring of the ID identifier of the encoder/motor feedback connection unit for detecting a break in the FX3-MOC1 connecting cable ³⁾ |
| <p>Two encoders with absolute position, optionally</p> <ul style="list-style-type: none"> • A/B • Sine/cosine • SSI <p>A/B and sine/cosine are each to be completed as follows:</p> <p>a)</p> <ul style="list-style-type: none"> • Reference cam (not safe) • Position by Reference without Memory Function function block • Reference run after restart <p>or</p> <p>b) (Maximum possible for one encoder)</p> <ul style="list-style-type: none"> • Initial referencing during commissioning • Position by Reference with Memory Function function block | 1 | | |

1) Actual values: [see table 169, page 161](#).

2) Configurable for sine/cosine encoders in the hardware configuration of the configuration software.

3) Can be used by any supported encoder type in the hardware configuration of the configuration software.

4) Can be used in the FX3-MOC1 logics. For details, see the “Flexi Soft in the Flexi Soft Designer Configuration Software” and “Flexi Soft in the Safety Designer Configuration Software” operating instructions.

Complementary information

The sine/cosine signals of a HIPERFACE® interface can also be connected to the encoder connection of the FX3-MOC1. In this way, the HIPERFACE® interface can be used like a sine/cosine encoder.

Other HIPERFACE® functions cannot be used.

Further topics

- ["Construction and function", page 17](#)
- ["Measures against common causes of error", page 127](#)

3.4.12 FX3-ANA0 analog input module

Overview

The FX3-ANA0 analog input module has two analog inputs for connecting analog signal transmitters (sensors). The two inputs form an input pair and are used to acquire an analog process variable. As part of a safety function, the FX3-ANA0 monitors whether the current value of this process variable (measured value) is within the permissible process range. In addition, it can assign the measured value to one of up to 15 configurable signal ranges.

The FX3-ANA0 analog input module offers the following functions:

- Plausibility check of the analog values detected at inputs AI1 and AI2
- Configurable evaluation of the detected analog values in the module
- Monitoring of up to 15 different process areas. A process area consists of an upper and a lower process area limit. If the measured process size of one of these limits is exceeded or undercut, the **Release** bit is set to 0. The process area to be monitored can be selected in ongoing operation.
- Subdivision of the maximum monitoring range into up to 15 configurable signal ranges
- Output of bits for **Enable** and the number of the current signal range to the main module for evaluation in the logic editor
- Output of sensor values via a gateway (16-bit, non-synchronous output, non-safe transmission)

Important information



NOTE

In some applications, it is necessary to monitor compliance with the ratio of the recorded sensor values. An explicit ratio formation of different values by the FX3-ANA0 is not possible.

Prerequisites

- The module can only be operated with a main module.

Analog input module FX3-ANA0

The FX3-ANA0 is supplied with voltage via the system plug of the main module and the internal FLEXBUS+ bus.

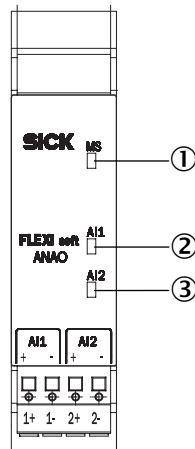

Figure 20: Analog input module FX3-ANA0

- ① MS LED (module status)
- ② LED AI1
- ③ LED AI2

Configuration

The FX3-ANA0 is configured using the Flexi Soft Designer or Safety Designer configuration software.

Devices with firmware < V2.00.0 are not supported by the Safety Designer configuration software.

For detailed information on configuring the FX3-ANA0, see the “Flexi Soft in the Flexi Soft Designer Configuration Software” and “Flexi Soft in the Safety Designer Configuration Software” operating instructions.

Sensors



WARNING

Ineffectiveness of the protective device due to selection of unsuitable sensors
The target safety-related level may not be achieved in the event of non-compliance.

- ▶ Select suitable sensors.
- ▶ Take suitable measures against the sensors’ systematic errors and common causes of error.

Choosing the right sensors is crucial to achieving the desired safety integrity level (SIL) and performance level (PL). Systematic faults and common cause faults (CCF), in particular, need to be minimized in this case.

Sensors featuring diverse redundancy are supported for the safe measurement of a process variable. The characteristic lines of the sensors are standardized in the module for this purpose. The standardized measured values of the two sensors are compared with one another in order to check their plausibility.

Uniformly redundant sensors can also be used. In this case, the characteristic lines of both sensors must have identical configurations.

Depending on the process variable, a time delay can occur at sensors which are attached at a distance from one another within a local area, or which have different transceivers. This transit time difference can be taken into account during the plausibility check.

Instead of two redundant sensors, an individual single-channel or dual-channel safety sensor can be used. A single-channel safety sensor must be connected in series to both inputs.

Further topics

- "Construction and function", page 17
- "Connecting analog sensors", page 98

3.4.13 UE410-2RO/UE410-4RO relay modules

Overview

The UE410-2RO/UE410-4RO relay modules provide dual-channel, contact-based outputs with what are known as positively guided relay contacts.

Important information



NOTE

The relay modules do not participate in communication via the internal FLEXBUS+ bus. Therefore, they cannot receive control signals from the main module.

Relay modules UE410-2RO/UE410-4RO

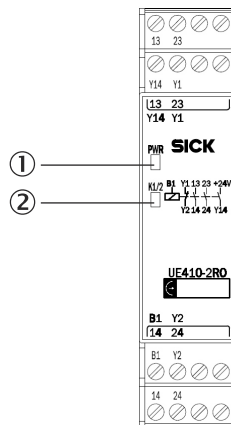

Figure 21: Relay module UE410-2RO

- ① PWR LED (power)
- ② K1/2 LED

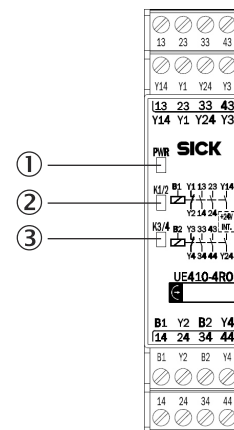

Figure 22: Relay module UE410-4RO

- ① PWR LED (power)
- ② K1/2 LED
- ③ K3/4 LED

Further topics

- "Construction and function", page 17

3.4.13.1 Internal circuitry

UE410-2RO

The UE410-2RO relay module has a control input (B1). This controls two internal relays and provides a redundant cut-off path, consisting of:

- Two safe enabling current paths (13/14, 23/24), dual-channel and volt-free
- One signaling current path (Y14), dual-channel and connected internally to 24 V DC
- One feedback circuit external device monitoring (Y1/Y2), dual-channel and volt-free

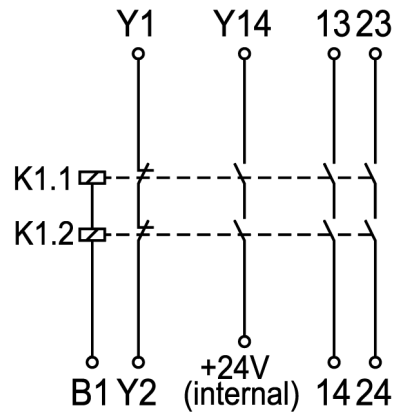

Figure 23: Internal structure of the UE410-2RO

UE410-4RO

The UE410-4RO relay module has two control inputs (B1, B2). These each control two internal relays. Two independent, redundant cut-off paths are therefore available.

Control input (B1) actuates two internal relays and provides a redundant cut-off path consisting of:

- Two safe enabling current paths (13/14, 23/24), dual-channel and volt-free
- One signaling current path (Y14), dual-channel and connected internally to 24 V DC
- One feedback circuit external device monitoring (Y1/Y2), dual-channel and volt-free

Control input (B2) actuates two internal relays and provides a redundant cut-off path consisting of:

- Two safe enabling current paths (33/34, 43/44), dual-channel and volt-free
- One signaling current path (Y24), dual-channel and connected internally to 24 V DC
- One feedback circuit external device monitoring (Y3/Y4), dual-channel and volt-free

This means that the UE410-4RO relay module has twice the number of functions as the UE410-2RO.

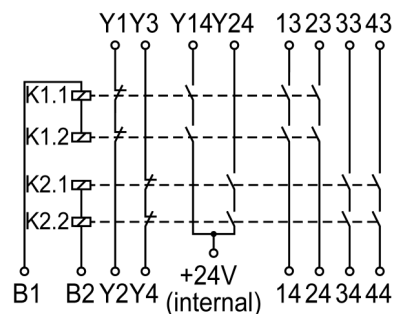

Figure 24: Internal structure of the UE410-4RO

3.5 Interfaces

3.5.1 RS-232

Each main module has an RS-232 interface with the following functions:

- Transfer configuration from the configuration software to the system plug
- Import configuration from the system plug into the configuration software
- Diagnose the Flexi Soft system with the configuration software
- Continuous diagnostics of the Flexi Soft system via a connected PLC As such the RS-232 interface can provide an alternative to a gateway.

Table 10: Pin assignment of the RS-232 interface on the FX3-CPUx

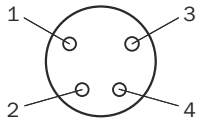
| Male connector/ Female connector | Pin | Signal | Color | Computer-side pin assignment RS-232 D-Sub (9-pin) |
|---|-----|---|-------|--|
|  | 1 | Reserved | Brown | - |
| | 2 | RxD | White | Pin 3 |
| | 3 | GND (connected electrically internally to connection A2 on the main module) | Blue | Pin 5 |
| | 4 | TxD | Black | Pin 2 |



NOTICE

Ground loops

The device may be damaged if this is not observed.

- ▶ Avoid ground loops between the GND connection of the RS-232 interface and the A2 connection of the main module, for instance by using optocouplers.
- ▶ If the RS-232 interface of the main module is permanently connected (e.g. as an alternative to a gateway), then observe the maximum permitted length of cable of 3 m.

3.5.2 USB

Overview

The FX3-CPU3 main module has a USB interface.

Functions of the USB interface:

- Transfer configuration from the configuration software to the system plug
- Import configuration from the system plug into the configuration software
- Diagnose the Flexi Soft system with the configuration software

Important information



NOTICE

The USB interface is not suitable for continuous operation.

- ▶ Only use the USB interface during configuration and diagnostics.

USB interface

Table 11: USB interface

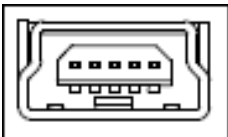
| | USB version | Connection type |
|---|-------------|-----------------|
|  | 2.0 | Mini-B |

3.5.3 Enhanced Function Interface (EFI)

The FX3-CPU1, FX3-CPU2, and FX3-CPU3 main modules each have 2 EFI interfaces. The properties, the functions, and the benefits of these interfaces are described in this section.

The general EFI description of operation and the combination options of SICK products regarding EFI can be found in the “EFI - enhanced function interface” technical information (SICK part number 8012611).

Definition

An EFI interface is safe communication interface between SICK devices. Information can be read from EFI-enabled devices and commands can be sent to EFI-enabled devices.

Properties

- Each EFI interface can support up to 4 SICK devices, as long as the EFI-enabled devices support this number.
- Device connection via 2-wire cable
- Various possible device combinations
 - Sensor with sensor in same product family
 - Sensor with safety controllers and gateways
 - Connection of up to four FX3-CPU1, FX3-CPU2, or FX3-CPU3 main modules to one Flexi Link system (see ["Flexi Link", page 45](#))
- Transfer of status information (process data) between SICK devices with EFI interface
- Transfer of configuration from the configuration software to EFI-enabled devices
- Import of configuration from EFI-enabled devices into the configuration software
- Activation/use of advanced software functions

Functions

Alongside the product-specific functions of each of the EFI-enabled devices, the following functions are available:

General functions

- Status information (process data) from the EFI-enabled devices is available in the controller and at the sensor.
- Diagnostic information from all EFI-enabled devices is available in the controller.
- Transfer of configuration information

Special functions

- Simultaneous protective field evaluation
- Protective field switching
- Function switching
- Operating mode selection
- Signal routing
- Remote diagnostic information via Ethernet
- Information about the location of an interruption in a protective field in the case of host-guest applications.
- Expansion of signals and forwarding of results

Benefits

- **Installation is quicker and less expensive** (only 2 conductors) when signals from multiple sensors are used
- **Decrease the material costs** with the savings potential of function blocks, inputs and outputs
- **Higher availability** thanks to the provision of diagnostic information with high information content for quick and accurate possible actions

3.6 Special functions

3.6.1 Flexi Link

Overview

Flexi Link allows you to combine up to four Flexi Soft stations via EFI for safe data exchange. Only main modules FX3-CPU1 and higher can be used in a Flexi Link system. FX3-CPU0 main modules cannot be connected.

The process data of each station (inputs and outputs, logic results, etc.) can be made available to all other stations in the Flexi Link system. The teach function can be used to deactivate individual stations temporarily without impairing the operation of the overall system.

Features

- Safe connection of up to four Flexi Soft stations via EFI
- Connection via EFI1 or EFI1+2
- Transmission/receipt of up to 52 bits of information per station (26 bits per EFI interface)
- A tag name that is valid globally can be assigned to each bit.
- Teaching simulates the presence of stations that have been temporarily suspended (switched off).
- Any station can be used for access in order to address and configure the entire system with the configuration software.
- The configuration of the entire Flexi Link system is saved in a unique project file.

System requirements and restrictions

The following minimum system requirements must be met for Flexi Link:

Table 12: System requirements for Flexi Link

| System component | Version |
|------------------|---|
| Hardware | FX3-CPU1, FX3-CPU2, or FX3-CPU3 with firmware version ≥ V2.00.0 |
| Software | Flexi Soft Designer version ≥ V1.3.0 |

The Flexi Link system can either be connected via EFI1 only or via EFI1+2. The number of pieces of data per station that can be made available to the other stations in the same Flexi Link system depends on which connection type is used.

Table 13: Available data depending on connection type

| Type of connection | Data availability per station |
|--------------------|-------------------------------|
| EFI1 | 26 bits |
| EFI1+2 | 52 bits |



NOTE

- You cannot use Flexi Link and EFI communication at the same time, i.e., it is not possible to connect other EFI-enabled devices to EFI2 if you are using EFI1 for Flexi Link.
- The process data sent from any station is received by all other stations at virtually the same time. However, the data is not necessarily processed (logic) at the same time, because the stations are not synchronized.
- The data is consistent within EFI1 and consistent within EFI2. However, the data from EFI1 and the data from EFI2 may be inconsistent for a short period of time because it is transmitted separately.

3.6.2 Flexi Line

Overview

Flexi Line allows you to network up to 32 Flexi Soft stations safely. Only main modules FX3-CPU3 and higher can be used in a Flexi Line system. It is not possible to connect any of the other main modules (FX3-CPU0, FX3-CPU1, FX3-CPU2).

A single process image is defined for the entire Flexi Line system. Each byte in this process image is valid either globally, i.e., in the entire system, or locally, i.e., only for the corresponding station and its neighbor stations. Each Flexi Line station uses this process image to communicate with its neighbor stations. Thanks to the topology, addresses are not required in order for communication to take place.

Features

- Safe connection of up to 32 Flexi Soft stations via the Flexi Line interface
- Topology without addresses: If the sequence of the stations changes, simply confirm the new arrangement by performing a teach-in operation.
- The EFI interface remains available without restrictions:
 - EFI-enabled devices can be connected.
 - A Flexi Link system can be connected.
- A global process image is defined for all stations.
- Bytes that are valid globally or locally can be defined in the process image.
- The process image can contain up to 12 bytes or 96 bits.
- The maximum cable length between 2 stations is 1,000 meters. The possible total length of a system with 32 stations is, therefore, 31 kilometers.

System requirements and restrictions

The following minimum system requirements must be met for Flexi Line:

Table 14: System requirements for Flexi Line

| System component | Version |
|------------------|--------------------------------------|
| Hardware | FX3-CPU3, every firmware version |
| Software | Flexi Soft Designer version ≥ V1.6.0 |



NOTE

- You can even use Flexi Link or EFI communication simultaneously with Flexi Line, i.e., it is possible to connect either EFI-enabled devices or Flexi Link stations.
- The process image is transferred from station to station at a fixed update rate. However, the data is not necessarily processed (logic) at the same time, because the stations are not synchronized.
- The update rate of the Flexi Line system is determined by the maximum cable length between two stations and the size of the process image.

Table 15: Update rate of a Flexi Line system dependent on the maximum cable length and the size of the process image

| Max. cable length | 32 bits | 64 bits | 96 bits |
|-------------------|---------|---------|---------|
| 125 m | 2 ms | 2 ms | 4 ms |
| 250 m | 2 ms | 4 ms | 8 ms |
| 500 m | 4 ms | 8 ms | 12 ms |
| 1,000 m | 8 ms | 12 ms | 20 ms |

3.6.3 Muting

General description

Muting is an automatic process that temporarily bridges safety-related functions of a control system or safety device. Muting allows certain objects, e.g., pallets loaded with material, to pass through electro-sensitive protective equipment (ESPE) such as a safety light curtain and into a hazardous area. During this transport operation, the muting function bridges monitoring by the electro-sensitive protective equipment.

For the further approach, observe the notes in the “Flexi Soft in the Flexi Soft Designer Configuration Software” and “Flexi Soft in the Safety Designer Configuration Software” operating instructions.

SICK muting sensors

A selection of optical muting sensors are presented below. You can use these sensors by type (light or dark switching).

Table 16: Selection and settings of optical SICK muting sensors in muting applications

| Model | Function |
|-------|-------------------------------------|
| W9-3 | Light/dark switching, complementary |
| W12-3 | |
| W18-3 | |
| W27-3 | |
| W24-3 | Light/dark switching, switchable |



NOTE

The following criteria apply when selecting and setting optical SICK muting sensors in muting applications:

- Outputs must be PNP-switching.
- Note the output level in the table below.

Table 17: Output level of muting sensors

| Output level of muting sensors | State |
|--------------------------------|-----------------------------------|
| High | Activated, material detected |
| Low | Deactivated, no material detected |

3.6.4 Automatic configuration recovery (ACR)

When an FX3-MPL1 system plug is used, EFI-enabled devices of the same type can be detected and automatically reconfigured further to a replacement (automatic configuration recovery). Advantages:

- Configuration backup of EFI sensors in FX3-CPU2 and FX3-CPU3
- Rapid device replacement without reconfiguration with the corresponding configuration software
- Quick and easy duplication of equipment in series machine manufacture

ACR can be used to restore the configuration of the following device families:

- S3000 with firmware version \geq B02.41, **not** in Compatibility mode. For details, refer to the “Compatibility mode” chapter of the S3000 operating instructions (SICK part number 8009791).
- S300 with firmware version \geq 02.10, **not** in Compatibility mode. For details, refer to the “Compatibility mode” chapter of the S300 operating instructions (SICK part number 8010946).
- S300 Mini

- M4000
- C4000

ACR **cannot** be used to restore the configuration of the following devices:

- UE product family (UE402/UE403, UE44xx, UE41xx, UExx40)
- Devices in the Flexi Soft product family (FX3-CPUx)

Please also refer to the information in the operating instructions for the EFI-enabled devices you are using.

The “Flexi Soft in the Flexi Soft Designer Configuration Software” operating instructions contain more information on using the ACR function.

4 Mounting

4.1 Mounting procedure

Overview

Assignment of the modules:

- The FX3-CPUx main module is located on the far left.
- You can use up to two gateways per safety controller. Mount the two optional gateways directly to the right of the main module.
- Mount all other expansion modules to the right of the gateway in any sequence.
- Mount any additional relay modules (UE410-2RO or UE410-4RO) to the right of the expansion modules.

Important information



WARNING

Electrical voltage

There is a risk of injury from electrocution while connecting the devices.

- ▶ Disconnect the power for the entire plant/machine.

Prerequisites

- The safety controller must be protected against condensation and conductive contamination, e.g. in an IP54 control cabinet.
- Mount the modules in accordance with EN 50274.
- Mount the modules on a 35 mm mounting rail in accordance with IEC 60715.
- The mounting rail is connected to the functional earth.
- Mounting in a vertical orientation (on a horizontal mounting rail). [figure 25](#)
- There is at least 50 mm of space for air circulation above and below the module.
- There is at least 25 mm of space in front of the module (front side). More space may be needed depending on the connections.
- Implement suitable measures to prevent any foreign bodies from entering the connector openings.
- Take suitable ESD protection measures.

Procedure

1. Attach module to mounting rail (①).
 2. Ensure the grounding clip (②) is seated flush against the DIN mounting rail so that it is secure and can conduct electricity effectively.
 3. Press the module into place on the DIN mounting rail in the direction of the arrow (③).
- ✓ The module engages with an audible click.

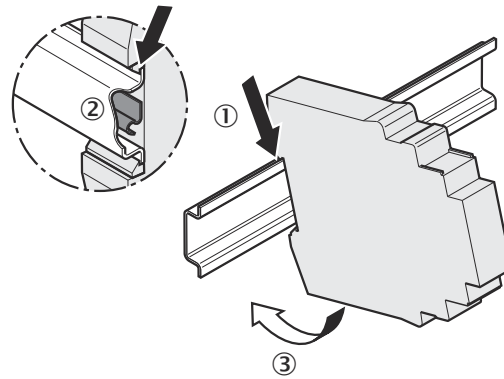

Figure 25: Mounting the module on the DIN mounting rail

4. Slide the modules together one by one (as indicated by the arrows) until the side-mounted plug connector engages.
5. Mount the end pieces on the left- and right-hand sides.

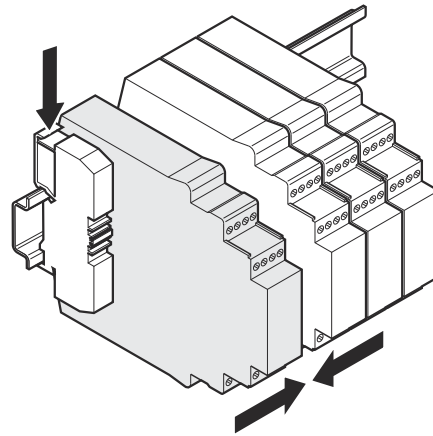

Figure 26: Attaching the end pieces

Complementary information

The modules are interconnected via a FLEXBUS+ plug connector, which is integrated into the housing. Before removing a module from the mounting rail, slide the modules approx. 10 mm apart.

5 Electrical installation

5.1 Requirements to be met by the electrical installation

**WARNING**

Electrical voltage

There is a risk of injury from electrocution while connecting the devices.

- ▶ Disconnect the power for the entire plant/machine.
-

**WARNING**

Unintended start of the plant/machine

The plant/machine could inadvertently start while you are connecting the devices.

- ▶ Disconnect the power for the entire plant/machine.
-

**WARNING**

Ineffectiveness of the protective device due to non-compliance with safety standards

The target safety-related level may not be achieved in the event of non-compliance.

- ▶ Observe the relevant safety standards (e.g. EN 62061, or EN ISO 13849-1) for all the safety-related parts of the plant (wiring, connected sensors and control devices, configuration, external device monitoring).
-

**NOTE**

For the electrical installation, observe the following:

- The Flexi Soft safety controller meets the EMC requirements stipulated by generic standard EN 61000-6-2 for the industrial sector.
- Industrial safety devices by SICK are only suitable for local direct current applications. If the device is being used on power supply networks, e.g., in accordance with IEC 61326-3-1, additional protective measures must be taken.
- Machines on which safety devices are being used must be installed and dimensioned as appropriate for the lightning zone in accordance with EN 62305-1. The required level can be achieved by using external protective devices. The devices used to provide protection against overvoltage must meet the requirements set out in EN 61643-11.
- The equipment must prevent common-mode disturbance as set out in IEC 61000-4-16 in the frequency range from 0 Hz to 150 kHz.
- To establish full EMC safety, you must connect the DIN mounting rail to functional earth (FE).
- The external voltage supply of the Flexi Soft modules must be capable of bridging brief power failures of 20 ms as specified in EN 60204-1, for example. Suitable PELV and SELV power supply units are available as accessories from SICK.
- The power supply and all connected signals must meet the requirements for low voltages with safe isolation (SELV, PELV) as set out in EN 60664 and EN 50178 (electronic equipment for use in power installations).
- Galvanically isolate the 24 V power circuit of the safety controller from the battery-operated power circuit using an encapsulated DC/DC converter in accordance with EN 1175 (e.g., when using AGVs).
- If the RS-232 interface on the main module is used as an alternative to a gateway, then the maximum permitted length of cable is 3 m.
- The GND of the RS-232 interface is connected internally to the GND connection of the main module's voltage supply (A2). Avoid ground loops between the GND connection of the RS-232 interface and the A2 connection of the main module, for instance by using optocouplers.
- Depending on the external loads and in particular in the case of inductive loads, additional external safety measures such as varistors or RC elements may be necessary in order to protect the outputs. For information on limitations in operation: see "Technical data", page 132. It must be considered that the response times may be extended depending on the type of suppressor.
- When modules are exchanged, the correct assignment of the terminals must be ensured, e.g. by labelling or routing the cables correspondingly.

Electrical installation

- ▶ Carry out the electrical installation work in conformity with EN 60204-1.
- ▶ Connect the shielding of all fieldbus and Ethernet cables to the functional earth (FE) directly at the control cabinet entry point.
- ▶ Connect the GND connections of the actuators to the outputs Q1 to Q4 in star formation with the GND connection of the voltage supply. Otherwise, an actuator (e.g. relay) could switch unintentionally if the common GND cable tears off, at least one output is high and at least one output for the actuators is low.
- ▶ Make sure that all the Flexi Soft system modules, the connected protective devices (e.g., the EFI-enabled devices), and the voltage supplies are all connected to the same ground. The ground of the RS-232 interface is connected internally to the ground of the main module's voltage supply (A2).

**WARNING**

Unintended high status at the inputs due to reverse current in case of loss of ground connection

The target safety-related level may not be achieved in the event of non-compliance.

The dangerous state may not be stopped or not be stopped in a timely manner in the event of non-compliance.

If several safety inputs are connected in parallel:

- ▶ Check whether this reverse current might lead to an unintentional high state, see "Technical data", page 132.
- ▶ Consider this possible error source in the risk analysis and risk avoidance strategy.

5.2 Description of the terminals

5.2.1 FX3-CPU0 main module

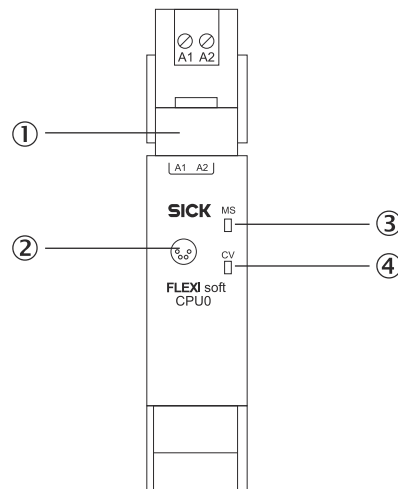

Figure 27: FX3-CPU0 main module

- ① FX3-MPL0 system plug
- ② RS-232 interface
- ③ MS LED (**M**odule **S**tatus)
- ④ CV LED (**C**onfiguration **V**erified)

Table 18: Pin assignment on the FX3-CPU0 main module with FX3-MLP0 system plug

| Terminal | Pin assignment |
|----------|--|
| A1 | 24 V power supply for all modules, with the exception of the supply to the outputs (Q1 ... Q4) |
| A2 | Power supply GND |

5.2.2 FX3-CPU1 and FX3-CPU2 main modules

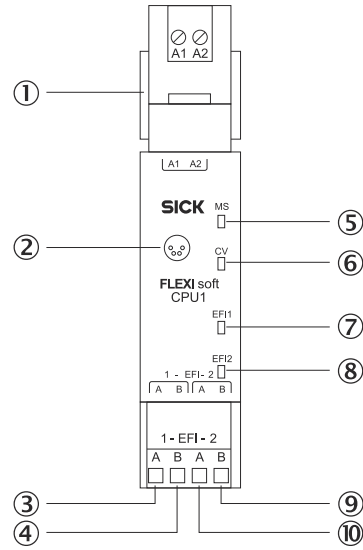

Figure 28: FX3-CPU1 main module

- ① FX3-MPL0 system plug
- ② RS-232 interface
- ③ EFI1_A
- ④ EFI1_B
- ⑤ MS LED (Module Status)
- ⑥ CV LED (Configuration Verified)
- ⑦ EFI1 LED
- ⑧ EFI2 LED
- ⑨ EFI2_B
- ⑩ EFI2_A

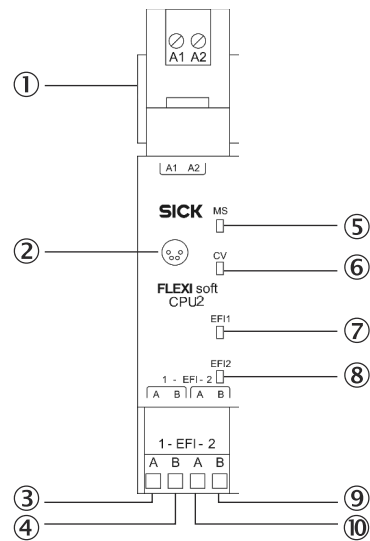

Figure 29: FX3-CPU2 main module

- ① FX3-MPL1 system plug
- ② RS-232 interface
- ③ EF1_A
- ④ EF1_B
- ⑤ MS LED (Module Status)
- ⑥ CV LED (Configuration Verified)
- ⑦ EF1 LED
- ⑧ EF2 LED
- ⑨ EF2_B
- ⑩ EF2_A

Table 19: Pin assignment at FX3-CPU1 main module with FX3-MPL0 system plug and at FX3-CPU2 main module with FX3-MPL1 system plug

| Terminal | Pin assignment |
|----------|--|
| A1 | 24 V power supply for all modules, with the exception of the supply to the outputs (Q1 ... Q4) |
| A2 | Power supply GND |
| EF1_A | Connections for EFI or for Flexi Link |
| EF1_B | |
| EF2_A | |
| EF2_B | |

5.2.3 FX3-CPU3 main module

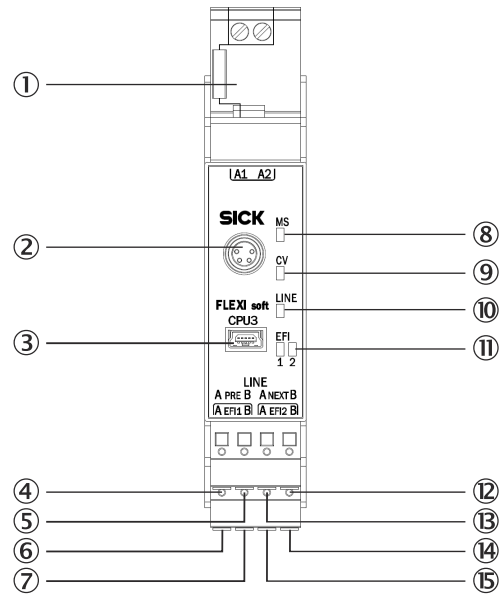

Figure 30: FX3-CPU3 main module

- ① FX3-MPL1 system plug
- ② RS-232 interface
- ③ USB interface
- ④ Line_PRE_A (previous)
- ⑤ Line_PRE_B (previous)
- ⑥ EFI1_A
- ⑦ EFI1_B
- ⑧ MS LED (Module Status)
- ⑨ CV LED (Configuration Verified)
- ⑩ LINE LED
- ⑪ EFI1 and EFI2 LEDs
- ⑫ Line_NEXT_B (next)
- ⑬ Line_NEXT_A (next)
- ⑭ EFI2_B
- ⑮ EFI2_A

Table 20: Pin assignment on the FX3-CPU3 main module with FX3-MLP1 system plug

| Terminal | Pin assignment |
|-------------|--|
| A1 | 24 V power supply for all modules, with the exception of the supply to the outputs (Q1 ... Q4) |
| A2 | Power supply GND |
| EFI1_A | Connections for EFI1 or for Flexi Link |
| EFI1_B | |
| EFI2_B | |
| EFI2_A | |
| Line_PRE_A | Connections for Flexi Line |
| Line_PRE_B | |
| Line_NEXT_A | |
| Line_NEXT_B | |

5.2.4 FX3-XTIO I/O module

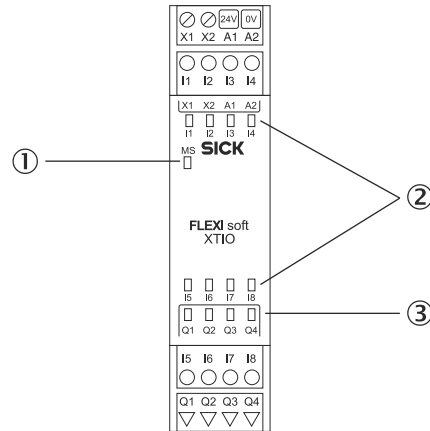

Figure 31: FX3-XTIO I/O module

- ① MS LED (Module Status)
- ② 8 input LEDs
- ③ 4 output LEDs

Table 21: Pin assignment for the FX3-XTIO I/O module

| Terminal | Pin assignment |
|-----------|-----------------------------|
| A1 | 24 V |
| A2 | GND |
| I1 ... I8 | Safety inputs 1 to 8 |
| Q1 ... Q4 | Safety outputs 1 to 4 |
| X1/X2 | Test output 1/Test output 2 |

**NOTE**

Use of the test outputs

The FX3-XTIO has two test outputs.

- For each device to be tested, one test output must be used of the same module to which the device is connected.
- If the device to be tested is connected to an odd-numbered input (I1, I3, I5, I7), then test output X1 must be used. If the device to be tested is connected to an even-numbered input (I2, I4, I6, I8), then test output X2 must be used.

5.2.5 FX3-XTDI I/O module

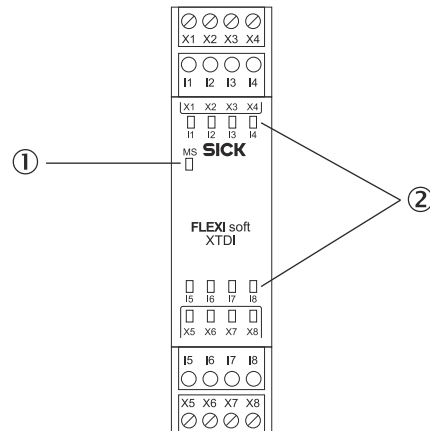

Figure 32: FX3-XTDI I/O module

- ① MS LED (Module Status)
- ② 8 input LEDs

Table 22: Pin assignment for the FX3-XTDI I/O module

| Terminal | Pin assignment |
|-------------|---|
| I1 ... I8 | Safety inputs 1 to 8 |
| X1/X3/X5/X7 | Test output 1 (test signal generator 1) |
| X2/X4/X6/X8 | Test output 2 (test signal generator 2) |



NOTE

Use of the test outputs

The FX3-XTDI has eight test outputs.

- For each device to be tested, one test output must be used of the same module to which the device is connected.
- If the device to be tested is connected to an odd-numbered input (I1, I3, I5, I7), then an odd-numbered test output (X1, X3, X5, X7) must be used. If the device to be tested is connected to an even-numbered input (I2, I4, I6, I8), then an even-numbered test output (X2, X4, X6, X8) must be used.

5.2.6 FX3-XTDS I/O module

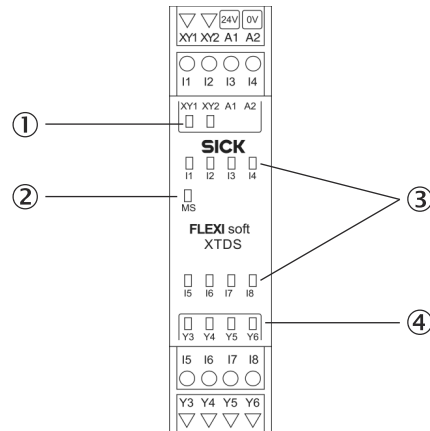

Figure 33: FX3-XTDS I/O module

- ① 2 LEDs for test outputs or non-safe outputs
- ② MS LED (Module Status)
- ③ 8 input LEDs
- ④ 4 output LEDs

Table 23: Pin assignment for the FX3-XTDS I/O module

| Terminal | Pin assignment |
|-----------|---|
| A1 | 24 V |
| A2 | GND |
| I1 ... I8 | Safety inputs 1 to 8 |
| Y3 ... Y6 | Non-safe outputs 3 to 6 |
| XY1/XY2 | Test output 1/Test output 2 or non-safe output 1/non-safe output 2 |

**NOTE**

Use of the test outputs

The FX3-XTDS has two optional test outputs.

- For each device to be tested, one test output must be used of the same module to which the device is connected.
- If the device to be tested is connected to an odd-numbered input (I1, I3, I5, I7), then test output XY1 must be used. If the device to be tested is connected to an even-numbered input (I2, I4, I6, I8), then test output XY2 must be used.

5.2.7 FX0-STIO I/O module

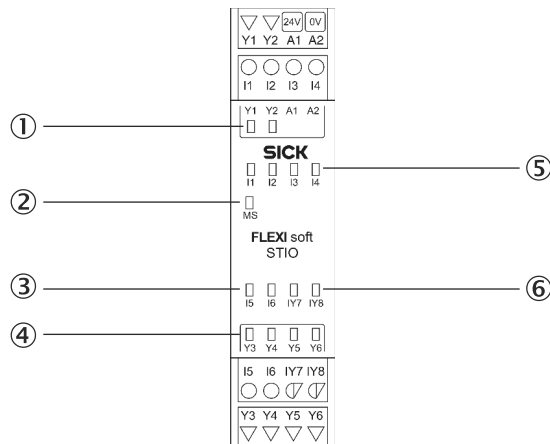

Figure 34: FX0-STIO I/O module

- ① 2 output LEDs
- ② MS LED (Module Status)
- ③ 2 input LEDs
- ④ 4 output LEDs
- ⑤ 4 input LEDs
- ⑥ 2 LEDs for configurable inputs or outputs

Table 24: Pin assignment for the FX0-STIO I/O module

| Terminal | Pin assignment |
|-----------|--|
| A1 | 24 V |
| A2 | GND |
| I1 ... I6 | Non-safe inputs 1 to 6 |
| IY7, IY8 | Non-safe inputs 7 and 8 or non-safe outputs 7 and 8 (configurable) |
| Y1 ... Y6 | Non-safe outputs 1 to 6 |

5.2.8 FX3-MOCx motion control module

Overview

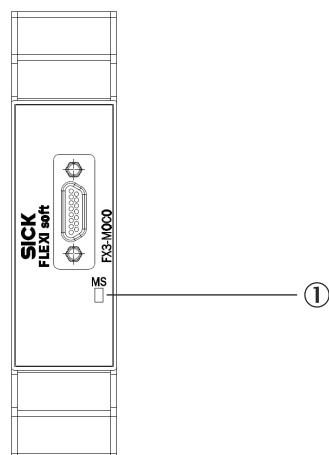

Figure 35: FX3-MOCx motion control module

- ① MS LED (Module Status)

A 15-pin Micro D-Sub male connector is positioned on the front of the FX3-MOCx for connecting up to two encoders.

Important information



NOTICE

The screws of the Micro-D-Sub male connector are to be tightened alternately by one turn until a torque of 0.2 Nm is achieved.



NOTE

- To make installation easier, we recommend using the connecting cables and encoder/motor feedback connection boxes that are available as accessories (see ["Accessories for the safety controller", page 184](#)).
- The signals are assigned based on the type of encoder used (see ["Connection of encoders", page 94](#)).

Pin assignment

Table 25: Pin assignment of the Micro-D-Sub male connector of the FX3-MOCx

| Male connector | Pin | Signal name | Encoder | Wiring ¹⁾ | | | | | |
|----------------|-----|-------------|---------|------------------------------------|---------|---|-----|--|---------|
| | | | | Sine/Cosine encoder | | A/B incremental encoder, 2 pairs of outputs (HTL 24 V, HTL 12 V, TTL) | | A/B incremental encoder, 2 outputs (HTL 24 V, HTL 12 V, TTL) | |
| | 1 | ENC1_A+ | 1 | Cos+ | Cos | A+ | A | A+ | Data+ |
| | 9 | ENC1_A- | | Cos- | Cos_Ref | A- | GND | A- | Data- |
| | 2 | ENC1_B+ | | Sin+ | Sin | B+ | B | - | - |
| | 10 | ENC1_B- | | Sin- | Sin_Ref | B- | GND | - | - |
| | 3 | ENC1_C+ | | - | - | - | - | B+ | Clock+ |
| | 11 | ENC1_C- | | - | - | - | - | B- | Clock - |
| | 4 | ENC1_24V | | 24 V voltage supply for encoder 1 | | | | | |
| | 8 | ENC2_A+ | 2 | Cos+ | Cos | A+ | A | - | Data+ |
| | 15 | ENC2_A- | | Cos- | Cos_Ref | A- | GND | - | Data- |
| | 7 | ENC2_B+ | | Sin+ | Sin | B+ | B | - | - |
| | 14 | ENC2_B- | | Sin- | Sin_Ref | B- | GND | - | - |
| | 6 | ENC2_C+ | | - | - | - | - | - | Clock+ |
| | 13 | ENC2_C- | | - | - | - | - | - | Clock - |
| | 5 | ENC2_24V | | 24 V voltage supply for encoder 2 | | | | | |
| | 12 | ENC_OV | 1 & 2 | GND connection for encoder 1 and 2 | | | | | |

1) A combination of different encoder types is possible.

2) Consider possible measures for common cause errors. See ["Motion Control FX3-MOC0", page 34](#) or ["Motion Control FX3-MOC1", page 36](#).

5.2.9 Encoder/motor feedback connection units

Overview

The encoder/motor feedback connection units available as accessories facilitate the connection of encoders to the encoder interface of the FX3-MOCx modules. This is especially true for encoders that are used both for an FX3 MOCx and as motor feedback of a drive system.

There are additional terminals on all encoder/motor feedback connection boxes. These are designed for forwarding signals which are not required for the FX3-MOCx module but can still be transmitted in the encoder cable (brake actuation, temperature sensor, etc.).

Prerequisites

- Mount encoder/motor feedback connection units in an environment that complies with enclosure rating IP54 (EN 60529), e.g. in a control cabinet with enclosure rating IP54.

Encoder/motor feedback connection units

On recommended connection types see "Connection of encoders", page 94.

Table 26: Encoder/motor feedback connection units

| FX3-EBX1 connection unit | FX3-EBX3 connection unit | FX3-EBX4 connection unit |
|---|---|---|
|  |  |  |
| <p>Figure 36: FX3-EBX1 connection overview</p> | <p>Figure 37: FX3-EBX3 connection overview</p> | <p>Figure 38: FX3-EBX4 connection overview</p> |
| <ul style="list-style-type: none"> • Connection option for 2 encoders • 2 additional free terminals per encoder for forwarding signals. | <ul style="list-style-type: none"> • Connection option for 1 encoder • 10 additional free terminals for forwarding signals. | <ul style="list-style-type: none"> • Connection option for 2 encoders • 2 additional free terminals for encoder 1 for forwarding signals. |

Table 27: Description of the connections

| | FX3-EBX1 connection unit | FX3-EBX3 connection unit | FX3-EBX4 connection unit |
|------------------|--|---|---|
| C1 | <ul style="list-style-type: none"> • Spring terminals for the connection of encoder signals of an encoder • 2 free terminals for forwarding other signals | <ul style="list-style-type: none"> • Plug-in spring terminals for the connection of encoder signals of an encoder • 2 free terminals for forwarding other signals | |
| C2 | <ul style="list-style-type: none"> • Spring terminals for the connection of encoder signals of another encoder • 2 free terminals for forwarding other signals | <ul style="list-style-type: none"> • Plug-in spring terminals with 8 free terminals for forwarding other signals | <ul style="list-style-type: none"> • Plug-in spring terminals for the connection of encoder signals of an additional encoder |
| C3 | <ul style="list-style-type: none"> • 15-pin HD-D-Sub female connector with M3 screws for connecting the connection cable to the FX3-MOCx | | |
| C4 | – | <ul style="list-style-type: none"> • 9-pin D-Sub female connector with M3 screws for connecting a second FX3-EBX3 encoder/motor feedback connection unit (forwarding the ENC2_x signals from the 15-pin HD D-Sub female connector) | – |
| U _{out} | – | <ul style="list-style-type: none"> • Selector switch of on-board voltage supply for encoder, powered by FX3-MOCx, switchable between 5 V, 7 V, 12 V and 24 V nominal | |
| | <ul style="list-style-type: none"> • Terminals for shielding the two cables from the encoder and to the motor controller for a low-resistance connection of the cable shields | | |
| | <ul style="list-style-type: none"> • ID identifier in combination with the voltage supply for evaluation by the FX3-MOCx | | |

Complementary information

The FX3-EBX3 and FX3-EBX4 connection units have shielding hoods for plug-in spring terminals C1 and C2 to provide protection against electromagnetic interference.

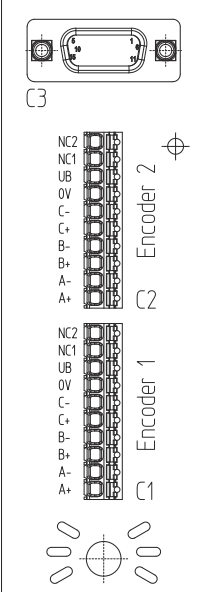
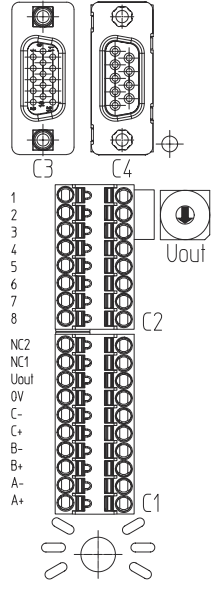
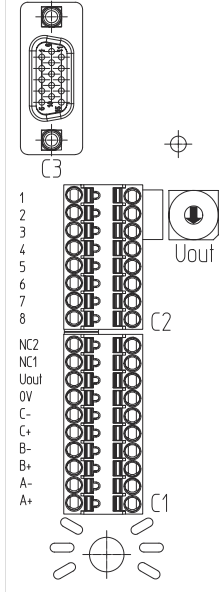
5.2.9.1 Pin assignment FX3-EBX1

C1 encoder connection

Table 28: C1 encoder connection, FX3-EBX1

| Terminal | Designation | Wiring | | | | | | |
|--|-------------|---------------------|---|--|-------------------------------------|-------------------------|-------------|---------|
| | | Sine/Cosine encoder | | A/B incremental encoder | | | SSI encoder | |
| | | | | 2 output pairs (HTL 24 V, HTL 12 V, TTL) | 2 outputs (HTL 24 V, HTL 12 V, TTL) | 2 output pairs (RS-422) | | |
| <div style="border: 1px solid black; padding: 2px; display: flex; flex-direction: column; align-items: center;"> <div style="border: 1px solid black; border-radius: 50%; width: 20px; height: 20px; display: flex; align-items: center; justify-content: center; margin-bottom: 2px;">1</div> <div style="border: 1px solid black; border-radius: 50%; width: 20px; height: 20px; display: flex; align-items: center; justify-content: center; margin-bottom: 2px;">2</div> <div style="border: 1px solid black; border-radius: 50%; width: 20px; height: 20px; display: flex; align-items: center; justify-content: center; margin-bottom: 2px;">3</div> <div style="border: 1px solid black; border-radius: 50%; width: 20px; height: 20px; display: flex; align-items: center; justify-content: center; margin-bottom: 2px;">4</div> <div style="border: 1px solid black; border-radius: 50%; width: 20px; height: 20px; display: flex; align-items: center; justify-content: center; margin-bottom: 2px;">5</div> <div style="border: 1px solid black; border-radius: 50%; width: 20px; height: 20px; display: flex; align-items: center; justify-content: center; margin-bottom: 2px;">6</div> <div style="border: 1px solid black; border-radius: 50%; width: 20px; height: 20px; display: flex; align-items: center; justify-content: center; margin-bottom: 2px;">7</div> <div style="border: 1px solid black; border-radius: 50%; width: 20px; height: 20px; display: flex; align-items: center; justify-content: center; margin-bottom: 2px;">8</div> <div style="border: 1px solid black; border-radius: 50%; width: 20px; height: 20px; display: flex; align-items: center; justify-content: center; margin-bottom: 2px;">9</div> <div style="border: 1px solid black; border-radius: 50%; width: 20px; height: 20px; display: flex; align-items: center; justify-content: center; margin-bottom: 2px;">10</div> </div> | 1 | NC2 | Not connected to the FX3-EBX1 ¹⁾ | | | | | |
| | 2 | NC1 | Not connected to the FX3-EBX1 ¹⁾ | | | | | |
| | 3 | ENC1_24V | 24 V voltage supply for encoder | | | | | |
| | 4 | ENC1_0V | GND connection for encoder | | | | | |
| | 5 | ENC1_C- | - | - | - | - | B- | Clock - |
| | 6 | ENC1_C+ | - | - | - | - | B+ | Clock+ |
| | 7 | ENC1_B- | Sin- | Sin_Ref | B- | GND | - | - |
| | 8 | ENC1_B+ | Sin+ | Sin | B+ | B | - | - |
| | 9 | ENC1_A- | Cos- | Cos_Ref | A- | GND | A- | Data- |
| | 10 | ENC1_A+ | Cos+ | Cos | A+ | A | A+ | Data+ |

¹⁾ Used to forward a signal, e.g. for an external voltage supply.

C2 encoder connection

Table 29: C2 encoder connection, FX3-EBX1

| Terminal | Designation | Wiring | | | | | | |
|--|-------------|---------------------|---|-------------------------------------|-------------------------|-------------|---|---------|
| | | Sine/Cosine encoder | A/B incremental encoder | | | SSI encoder | | |
| | | | 2 output pairs (HTL 24 V, HTL 12 V, TTL) | 2 outputs (HTL 24 V, HTL 12 V, TTL) | 2 output pairs (RS-422) | | | |
|  | 1 | NC2 | Not connected to the FX3-EBX1 ¹⁾ | | | | | |
| | 2 | NC1 | Not connected to the FX3-EBX1 ¹⁾ | | | | | |
| | 3 | ENC2_24V | 24 V voltage supply for encoder | | | | | |
| | 4 | ENC2_0V | GND connection for encoder | | | | | |
| | 5 | ENC2_C- | - | - | - | - | - | Clock - |
| | 6 | ENC2_C+ | - | - | - | - | - | Clock+ |
| | 7 | ENC2_B- | Sin- | Sin_Ref | B- | GND | - | - |
| | 8 | ENC2_B+ | Sin+ | Sin | B+ | B | - | - |
| | 9 | ENC2_A- | Cos- | Cos_Ref | A- | GND | - | Data- |
| | 10 | ENC2_A+ | Cos+ | Cos | A+ | A | - | Data+ |

¹⁾ Used to forward a signal, e.g. for an external voltage supply.

C3 HD-D-Sub female connector

Table 30: 00C3 HD-D-Sub female connector, FX3-EBX1, for connection to FX3-MOCx

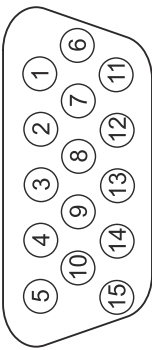
| Female connector | PIN | Designation |
|---|-----|-------------|
|  | 1 | ENC1_A+ |
| | 2 | ENC1_A- |
| | 3 | ENC1_24V |
| | 4 | ENC2_A+ |
| | 5 | ENC2_A- |
| | 6 | ENC1_B+ |
| | 7 | ENC1_B- |
| | 8 | ENC_0V |
| | 9 | ENC2_B+ |
| | 10 | ENC2_B- |
| | 11 | ENC1_C+ |
| | 12 | ENC1_C- |
| | 13 | ENC2_24V |
| | 14 | ENC2_C+ |
| | 15 | ENC2_C- |

5.2.9.2 Pin assignment FX3-EBX3

C1 encoder connection

Table 31: Encoder connection C1, FX3-EBX3

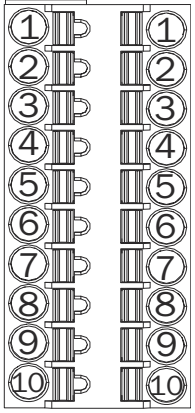
| Terminal | Designation | Wiring | | | | | | |
|---|-------------|-----------------------|--|-------------------------------------|---|-------------|----|---------|
| | | Sine/Cosine encoder | A/B incremental encoder | | | SSI encoder | | |
| | | | 2 output pairs (HTL 24 V, HTL 12 V, TTL) | 2 outputs (HTL 24 V, HTL 12 V, TTL) | 2 pairs of outputs (RS-422) ¹⁾ | | | |
|  | 1 | NC2 | Not connected to the FX3-EBX3 ²⁾ | | | | | |
| | 2 | NC1 | Not connected to the FX3-EBX3 ²⁾ | | | | | |
| | 3 | U _{out} | Encoder voltage supply from the on-board voltage supply of this FX3-EBX3, switchable between 5 V, 7 V, 12 V and 24 V nominal | | | | | |
| | 4 | ENCx_OV ³⁾ | GND connection for encoder | | | | | |
| | 5 | ENCx_C- ³⁾ | - | - | - | - | B- | Clock - |
| | 6 | ENCx_C+ ³⁾ | - | - | - | - | B+ | Clock+ |
| | 7 | ENCx_B- ³⁾ | Sin- | Sin_Ref | B- | GND | - | - |
| | 8 | ENCx_B+ ³⁾ | Sin+ | Sin | B+ | B | - | - |
| | 9 | ENCx_A- ³⁾ | Cos- | Cos_Ref | A- | GND | A- | Data- |
| | 10 | ENCx_A+ ³⁾ | Cos+ | Cos | A+ | A | A+ | Data+ |

1) Only for encoder 1, i.e. if it is the first encoder/motor feedback connection unit.

2) Used to forward a signal, e.g. for an external voltage supply (instead of using U_{out}).

3) x = 1 if it is the first encoder/motor feedback connection unit, i.e. if plug connector C3 is directly connected to the FX3-MOCx.

x = 2 if it is the second encoder/motor feedback connection unit, i.e. if plug connector C3 is connected to another encoder/motor feedback connection unit.

C2

Table 32: C2 terminal, FX3-EBX3

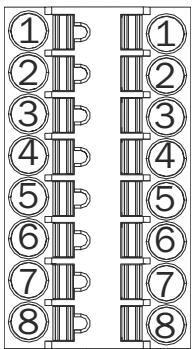
| Terminal | Designation | Description |
|---|-------------|-------------|
|  | 1 | NC |
| | 2 | NC |
| | 3 | NC |
| | 4 | NC |
| | 5 | NC |
| | 6 | NC |
| | 7 | NC |
| | 8 | NC |

Not connected to the FX3-EBX3, only used to forward signals

C3 HD-D-Sub female connector

Table 33: 00C3 HD-D-Sub female connector, FX3-EBX3, for connection to FX3-MOCx

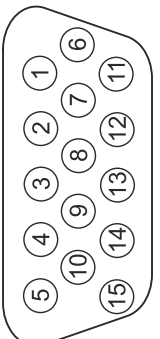
| Female connector | PIN | Designation |
|---|-----|-------------|
|  | 1 | ENC1_A+ |
| | 2 | ENC1_A- |
| | 3 | ENC1_24V |
| | 4 | ENC2_A+ |
| | 5 | ENC2_A- |
| | 6 | ENC1_B+ |
| | 7 | ENC1_B- |
| | 8 | ENC_0V |
| | 9 | ENC2_B+ |
| | 10 | ENC2_B- |
| | 11 | ENC1_C+ |
| | 12 | ENC1_C- |
| | 13 | ENC2_24V |
| | 14 | ENC2_C+ |
| | 15 | ENC2_C- |

C4 D-Sub female connector

The EBX3 connection unit also has a 9-pin D-Sub female connector for connecting a second FX3-EBX3 encoder/motor feedback connection unit.



NOTE

- The connection of a dual encoder/motor feedback connection unit FX3-EBX4 is not permitted here.
- A maximum of two encoder/motor feedback connection units are FX3-EBX3 are allowed per FX3 MOCx module.

Table 34: C4 D-Sub female connector, FX3-EBX3

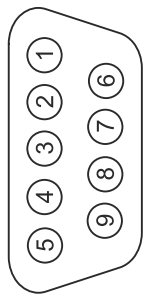
| Female connector | PIN | Designation |
|---|-----|---|
|  | 1 | ENC_A+ |
| | 2 | ENC_B+ |
| | 3 | ENC_C+ |
| | 4 | Reserved (ID identifier in combination with voltage supply) |
| | 5 | ENC_24V |
| | 6 | ENC_A- |
| | 7 | ENC_B- |
| | 8 | ENC_C- |
| | 9 | ENC_0V |

5.2.9.3 Pin assignment FX3-EBX4

C1 encoder connection

Table 35: C1 encoder connection, FX3-EBX4

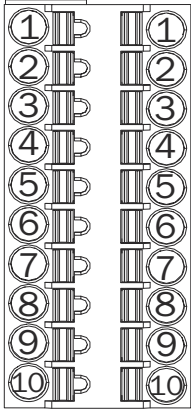
| Terminal | Designation | Wiring | | | | | | |
|---|-------------|---------------------|--|-------------------------------------|-------------------------|-------------|----|---------|
| | | Sine/Cosine encoder | A/B incremental encoder | | | SSI encoder | | |
| | | | 2 output pairs (HTL 24 V, HTL 12 V, TTL) | 2 outputs (HTL 24 V, HTL 12 V, TTL) | 2 output pairs (RS-422) | | | |
|  | 1 | NC2 | Not connected to the FX3-EBX4 ¹⁾ | | | | | |
| | 2 | NC1 | Not connected to the FX3-EBX4 ¹⁾ | | | | | |
| | 3 | U _{out} | Encoder voltage supply from the on-board voltage supply of this FX3-EBX4, switchable between 5 V, 7 V, 12 V and 24 V nominal | | | | | |
| | 4 | ENC1_0V | GND connection for encoder | | | | | |
| | 5 | ENC1_C- | - | - | - | - | B- | Clock - |
| | 6 | ENC1_C+ | - | - | - | - | B+ | Clock+ |
| | 7 | ENC1_B- | Sin- | Sin_Ref | B- | GND | - | - |
| | 8 | ENC1_B+ | Sin+ | Sin | B+ | B | - | - |
| | 9 | ENC1_A- | Cos- | Cos_Ref | A- | GND | A- | Data- |
| | 10 | ENC1_A+ | Cos+ | Cos | A+ | A | A+ | Data+ |

¹⁾ Used to forward a signal, e.g. for an external voltage supply (instead of using U_{out}).

C2 encoder connection

Table 36: C2 encoder connection, FX3-EBX4

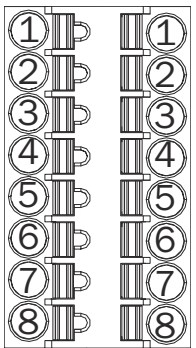
| Terminal | Designation | Wiring | | | | | | |
|---|-------------|---------------------|--|-------------------------------------|-------------------------|-------------|---|---------|
| | | Sine/Cosine encoder | A/B incremental encoder | | | SSI encoder | | |
| | | | 2 output pairs (HTL 24 V, HTL 12 V, TTL) | 2 outputs (HTL 24 V, HTL 12 V, TTL) | 2 output pairs (RS-422) | | | |
|  | 1 | U _{out} | Encoder voltage supply from the on-board voltage supply of this FX3-EBX4, switchable between 5 V, 7 V, 12 V and 24 V nominal | | | | | |
| | 2 | ENC2_0V | GND connection for encoder | | | | | |
| | 3 | ENC2_C- | - | - | - | - | - | Clock - |
| | 4 | ENC2_C+ | - | - | - | - | - | Clock+ |
| | 5 | ENC2_B- | Sin- | Sin_Ref | B- | GND | - | - |
| | 6 | ENC2_B+ | Sin+ | Sin | B+ | B | - | - |
| | 7 | ENC2_A- | Cos- | Cos_Ref | A- | GND | - | Data- |
| | 8 | ENC2_A+ | Cos+ | Cos | A+ | A | - | Data+ |

C3 HD-D-Sub female connector

Table 37: 00C3 HD-D-Sub female connector, FX3-EBX4, for connection to FX3-MOCx

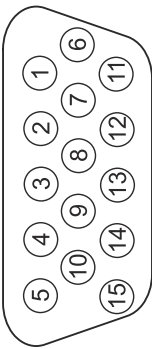
| Female connector | PIN | Designation |
|---|-----|-------------|
|  | 1 | ENC1_A+ |
| | 2 | ENC1_A- |
| | 3 | ENC1_24V |
| | 4 | ENC2_A+ |
| | 5 | ENC2_A- |
| | 6 | ENC1_B+ |
| | 7 | ENC1_B- |
| | 8 | ENC_0V |
| | 9 | ENC2_B+ |
| | 10 | ENC2_B- |
| | 11 | ENC1_C+ |
| | 12 | ENC1_C- |
| | 13 | ENC2_24V |
| | 14 | ENC2_C+ |
| | 15 | ENC2_C- |

5.2.9.4 On-board voltage supply U_{out}

Overview

The FX3-EBX3 and FX3-EBX4 connection units have an on-board voltage supply. The on-board voltage supply can optionally be used for the encoders and is powered by the FX3-MOCx (C3.ENC1_24V and C3.ENC2_24V). Output voltage U_{out} can be switched between 5 V, 7 V, 12 V and 24 V nominal by means of a rotary switch.

Important information



NOTICE

The voltage peaks when switching the supply voltage

The encoder/motor feedback connection unit may be damaged if this is not observed.

- ▶ Only actuate the rotary switch for the supply voltage on the encoder/motor feedback connection unit when the voltage supply is switched off.

On-board voltage supply U_{out}

Table 38: Setting of supply voltage for the encoders at FX3-EBX3 and FX3-EBX4

| Switch setting | Supply voltage U_{out} | Notes |
|----------------|--------------------------|--|
| 0 | 5 V | Tolerance U_{out} : 5% |
| 1 | 7 V | |
| 2 | 12 V | |
| 3 | 24 V nominal | Depending on the voltage level of the Flexi Soft voltage supply at the system plug |

Complementary information

Avoid common cause errors when using the on-board voltage supply, see ["Motion Control FX3-MOC0"](#), page 34 and see ["Motion Control FX3-MOC1"](#), page 36.

5.2.10 FX3-EBX connecting cables

Important information



NOTICE

Tighten the screws of the D-Sub male connectors alternately with one turn each until the torque is reached.

Torque:

- Torque for Micro-D-Sub male connector of FX3-MOC: 0.2 Nm
- Torque for the Sub-D male connector of the EBX connection unit: 0.7 Nm

Connecting cable between the FX3-MOC motion control module and an FX3-EBX encoder/motor feedback connection unit

Connection cables with material numbers and dimensions, [see table 199, page 185](#)

Table 39: Connecting cable for FX3-MOCx and FX3-EBXx

| Micro D-sub male connector of the FX3-MOCx | | Sub-D male connector of the EBX connection unit |
|--|-------------|---|
| PIN | Designation | PIN |
| 1 | ENC1_A+ | 1 |
| 2 | ENC1_B+ | 6 |
| 3 | ENC1_C+ | 11 |
| 4 | ENC1_24V | 3 |
| 5 | ENC2_24V | 13 |
| 6 | ENC2_C+ | 14 |
| 7 | ENC2_B+ | 9 |
| 8 | ENC2_A+ | 4 |
| 9 | ENC1_A- | 2 |
| 10 | ENC1_B- | 7 |
| 11 | ENC1_C- | 12 |
| 12 | ENC_0V | 8 |
| 13 | ENC2_C- | 15 |
| 14 | ENC2_B- | 10 |
| 15 | ENC2_A- | 5 |

Connecting cable between two FX3-EBX encoder/motor feedback connection units

Connection cables with material numbers and dimensions, [see table 200, page 185](#)

Table 40: Connecting cable for FX3-EBX3 and FX3-EBX4

| Sub-D male connector of the EBX connection unit | | Sub-D male connector of the EBX connection unit |
|---|-------------|---|
| PIN | Designation | PIN |
| 1 | ENC1_A+ | 1 |
| 2 | ENC1_B+ | 6 |
| 3 | ENC1_C+ | 11 |
| 4 | ENC1_24V | 3 |
| 5 | ENC2_24V | 13 |
| 6 | ENC2_A- | 2 |
| 7 | ENC2_B- | 7 |

| Sub-D male connector of the EBX connection unit | | Sub-D male connector of the EBX connection unit |
|---|-------------|---|
| PIN | Designation | PIN |
| 8 | ENC2_C- | 12 |
| 9 | ENC_OV | 8 |
| N.C. | | 4 |
| N.C. | | 5 |
| N.C. | | 9 |
| N.C. | | 10 |
| N.C. | | 14 |
| N.C. | | 15 |

Further topics

- "FX3-MOCx motion control module", page 60
- "Accessories for the motion control module", page 184

5.2.11 Encoder connection cables

Important information



NOTICE

Tighten the screws of the Micro D-sub male connector alternately by one turn until a torque of 0.2 Nm is achieved.



NOTICE

Tighten the M12 male connector with a torque of 0.6 Nm.

Connecting cables for two encoders with flying leads

Connecting cables with material numbers and dimensions, [see table 202, page 186](#)

Table 41: Connecting cables for two encoders with flying leads

| Open end | Micro D-sub male connector of the FX3-MOCx | | Wiring ¹⁾ | | | | | |
|--|--|-------------------------|----------------------|---------|-------------|---------------------|-------------------------|---------|
| | | | Wire color | PIN | Designation | Sine/Cosine encoder | A/B incremental encoder | |
| 2 output pairs (HTL 24 V, HTL 12 V, TTL) | 2 outputs (HTL 24 V, HTL 12 V, TTL) | 2 output pairs (RS-422) | | | | | | |
| Encoder 1 | | | | | | | | |
| White | 1 | ENC1_A+ | Cos+ | Cos | A+ | A | A+ | Data+ |
| Brown | 9 | ENC1_A- | Cos- | Cos_Ref | A- | GND | A- | Data- |
| Green | 2 | ENC1_B+ | Sin+ | Sin | B+ | B | - | - |
| Yellow | 10 | ENC1_B- | Sin- | Sin_Ref | B- | GND | - | - |
| Gray | 3 | ENC1_C+ | - | - | - | - | B+ | Clock+ |
| Pink | 11 | ENC1_C- | - | - | - | - | B- | Clock - |
| Encoder 2 | | | | | | | | |
| Black | 8 | ENC2_A+ | Cos+ | Cos | A+ | A | - | Data+ |

| Open end | Micro D-sub male connector of the FX3-MOCx | | Wiring ¹⁾ | | | | | |
|-----------------------|--|----------|------------------------------------|---------------------|--|-------------------------------------|-------------------------|---------|
| | Wire color | PI N | Designation | Sine/Cosine encoder | | A/B incremental encoder | | |
| | | | | | 2 output pairs (HTL 24 V, HTL 12 V, TTL) | 2 outputs (HTL 24 V, HTL 12 V, TTL) | 2 output pairs (RS-422) | |
| Violet | 15 | ENC2_A- | Cos- | Cos_Ref | A- | GND | - | Data- |
| Gray/pink | 7 | ENC2_B+ | Sin+ | Sin | B+ | B | - | - |
| Red/blue | 14 | ENC2_B- | Sin- | Sin_Ref | B- | GND | - | - |
| White/green | 6 | ENC2_C+ | - | - | - | - | - | Clock+ |
| Brown/green | 13 | ENC2_C- | - | - | - | - | - | Clock - |
| Voltage supply | | | | | | | | |
| Blue | 4 | ENC1_24V | 24 V voltage supply for encoder 1 | | | | | |
| Red | 5 | ENC2_24V | 24 V voltage supply for encoder 2 | | | | | |
| White/yellow | 12 | ENC_OV | GND connection for encoder 1 and 2 | | | | | |

1) A combination of different encoder types is possible.

Y-connecting cable for directly connecting two encoders

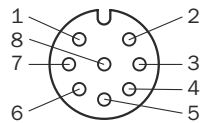

Figure 39: M12 female connector, 8-pin

Connecting cables with material numbers and dimensions, [see table 203, page 186](#)

Table 42: Y-connecting cable for directly connecting two encoders

| 2× M12, female connector, 8-pin | Micro D-sub male connector of the FX3-MOCx | | Wiring ¹⁾ | | | | | |
|---------------------------------|--|---------|----------------------|---------------------|--|---|-------------------------|--------|
| | PIN | PI N | Designation | Sine/Cosine encoder | | A/B incremental encoder | | |
| | | | | | 2 output pairs (HTL 24 V, HTL 12 V, TTL) ²⁾ | 2 outputs (HTL 24 V, HTL 12 V, TTL) ²⁾ | 2 output pairs (RS-422) | |
| Encoder 1 | | | | | | | | |
| 1 | 9 | ENC1_A- | Cos- | Cos_Ref | A- | GND | - | Data- |
| 2 | 1 | ENC1_A+ | Cos+ | Cos | A+ | A | - | Data+ |
| 3 | 10 | ENC1_B- | Sin- | Sin_Ref | B- | GND | - | - |
| 4 | 2 | ENC1_B+ | Sin+ | Sin | B+ | B | - | - |
| 5 | 3 | ENC1_C+ | - | - | - | - | - | Clock+ |

| 2× M12, female connector, 8-pin | | Micro D-sub male connector of the FX3-MOCx | | Wiring ¹⁾ | | | | |
|---------------------------------|-----|--|-----------------------------------|----------------------|--|---|-------------------------|---------------------------|
| PIN | PIN | Designation | Sine/Cosine encoder | | A/B incremental encoder | | | SSI encoder ²⁾ |
| | | | | | 2 output pairs (HTL 24 V, HTL 12 V, TTL) ²⁾ | 2 outputs (HTL 24 V, HTL 12 V, TTL) ²⁾ | 2 output pairs (RS-422) | |
| 6 | 11 | ENC1_C- | - | - | - | - | - | Clock - |
| 7 | 12 | ENC_0V | GND connection for encoder 1 | | | | | |
| 8 | 4 | ENC1_24V | 24 V voltage supply for encoder 1 | | | | | |
| Encoder 2 | | | | | | | | |
| 1 | 15 | ENC2_A- | Cos- | Cos_Ref | A- | GND | - | Data- |
| 2 | 8 | ENC2_A+ | Cos+ | Cos | A+ | A | - | Data+ |
| 3 | 14 | ENC2_B- | Sin- | Sin_Ref | B- | GND | - | - |
| 4 | 7 | ENC2_B+ | Sin+ | Sin | B+ | B | - | - |
| 5 | 6 | ENC2_C+ | - | - | - | - | - | Clock+ |
| 6 | 13 | ENC2_C- | - | - | - | - | - | Clock - |
| 7 | 12 | ENC_0V | GND connection for encoder 2 | | | | | |
| 8 | 5 | ENC2_24V | 24 V voltage supply for encoder 2 | | | | | |

¹⁾ A combination of different encoder types is possible.

²⁾ Consider possible measures for common cause errors. See "Motion Control FX3-MOC0", page 34 or "Motion Control FX3-MOC1", page 36.

Connecting cable for direct connection of the AFS/AFM60Spro safety encoder

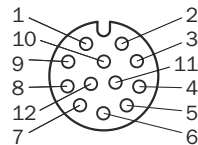

Figure 40: Female connector, M12, 12-pin

Connecting cables with material numbers and dimensions, see table 201, page 185

Table 43: Connecting cable for direct connection of the AFS/AFM60Spro safety encoder

| 1× M12, female connector, 12-pin | Micro D-sub male connector of the FX3-MOCx | | Wiring |
|----------------------------------|--|-------------|---------------------------------|
| PIN | PIN | Designation | SSI + Sin/Cos encoder |
| 1 | - | - | - |
| 2 | 1 | ENC1_A+ | Data+ |
| 3 | 9 | ENC1_A- | Data- |
| 4 | 11 | ENC1_C- | Clock- |
| 5 | 4 | ENC1_24V | 24 V voltage supply for encoder |
| 6 | 8 | ENC2_A+ | Cos+ |
| 7 | 15 | ENC2_A- | Cos- |
| 8 | 7 | ENC2_B+ | Sin+ |

| 1× M12, female connector, 12-pin | Micro D-sub male connector of the FX3-MOCx | | Wiring |
|----------------------------------|--|-------------|----------------------------|
| PIN | PIN | Designation | SSI + Sin/Cos encoder |
| 9 | 14 | ENC2_B- | Sin- |
| 10 | - | - | - |
| 11 | 3 | ENC1_C+ | Clock+ |
| 12 | 12 | ENC_OV | GND connection for encoder |

Connecting cable for directly connecting a Sine/Cosine encoder

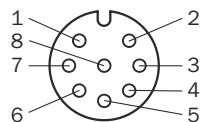

Figure 41: Female connector, M12, 8-pin

Connecting cables with material numbers and dimensions, [see table 201, page 185](#)

Table 44: Connecting cable for directly connecting a Sine/Cosine encoder

| 1× M12, female connector, 8-pin | Micro D-sub male connector of the FX3-MOCx | | Wiring |
|---------------------------------|--|-------------|---------------------------------|
| PIN | PIN | Designation | Sine/Cosine encoder |
| 1 | 9 | ENC1_A- | Cos- |
| 2 | 1 | ENC1_A+ | Cos+ |
| 3 | 10 | ENC1_B- | Sin- |
| 4 | 2 | ENC1_B+ | Sin+ |
| 5 | 3 | ENC1_C+ | - |
| 6 | 11 | ENC1_C- | - |
| 7 | 12 | ENC_OV | GND connection for encoder |
| 8 | 4 | ENC1_24V | 24 V voltage supply for encoder |

Connecting cable for directly connecting an SSI encoder

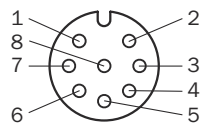

Figure 42: M12 female connector, 8-pin

Connecting cables with material numbers and dimensions, [see table 201, page 185](#)

Table 45: Connecting cable for directly connecting an SSI encoder

| 1× M12, female connector, 8-pin | Micro D-sub male connector of the FX3-MOCx | | Wiring |
|---------------------------------|--|-------------|-------------|
| PIN | PIN | Designation | SSI encoder |
| 1 | 9 | ENC1_A- | Data- |
| 2 | 1 | ENC1_A+ | Data+ |
| 3 | 10 | ENC1_B- | - |
| 4 | 2 | ENC1_B+ | - |

| 1× M12, female connector, 8-pin | Micro D-sub male connector of the FX3-MOCx | | Wiring |
|---------------------------------|--|-------------|---------------------------------|
| PIN | PIN | Designation | SSI encoder |
| 5 | 3 | ENC1_C+ | Clock+ |
| 6 | 11 | ENC1_C- | Clock- |
| 7 | 12 | ENC_OV | GND connection for encoder |
| 8 | 4 | ENC1_24V | 24 V voltage supply for encoder |

Further topics

- ["FX3-MOCx motion control module", page 60](#)
- ["Accessories for the motion control module", page 184](#)

5.2.12 FX3-ANA0 analog input module

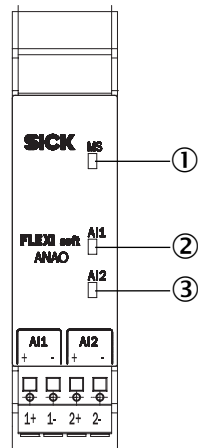

Figure 43: FX3-ANA0 analog input module

- ① MS LED (module status)
- ② LED AI1
- ③ LED AI2

Table 46: Pin assignment for the FX3-ANA0 analog input module

| Terminal | Pin assignment |
|----------|------------------|
| 1+, 1- | Analog input AI1 |
| 2+, 2- | Analog input AI2 |

5.2.13 UE410-2RO and UE410-4RO relay modules

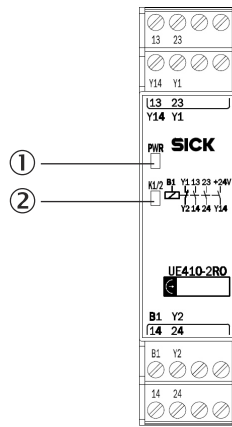

Figure 44: UE410-2RO relay module

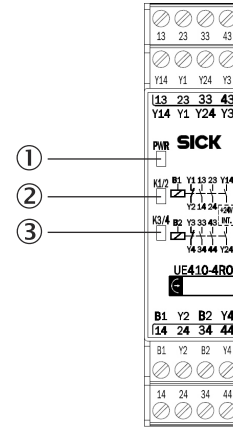

Figure 45: UE410-4RO relay module

- | | | | |
|---|-----------------|---|-----------------|
| ① | PWR LED (power) | ① | PWR LED (power) |
| ② | K1/2 LED | ② | K1/2 LED |
| | | ③ | K3/4 LED |

Table 47: Pin assignment for the UE410-2RO relay module

| Terminal | Pin assignment |
|-----------------|---|
| B1 | Wiring of relay K1/K2 |
| 13/14 and 23/24 | Safety contacts for cutoff circuit K1/K2 |
| Y1/Y2 | Feedback circuit external device monitoring (EDM), normally closed |
| Y14 | Safety contact K1 / K2, current limited, normally open contact (see "Technical data", page 132) |

Table 48: Pin assignment for the UE410-4RO relay module

| Terminal | Pin assignment |
|-----------------|---|
| B1 | Wiring of relay K1/K2 |
| B2 | Wiring of relay K3/K4 |
| 13/14 and 23/24 | Safety contacts for cut-off circuit outputs K1/K2 |
| 33/34 and 43/44 | Safety contacts for cut-off circuit outputs K3/K4 |
| Y1/Y2 | Feedback circuit external device monitoring K1/K2, normally closed |
| Y3/Y4 | Feedback circuit external device monitoring K3/K4, normally closed |
| Y14 | Safety contact K1 / K2, current limited, normally open contact (see "Technical data", page 132) |
| Y24 | Safety contact K3 / K4, current limited, normally open contact (see "Technical data", page 132) |

The UE410-2RO/UE410-4RO relay modules cannot be used alone, but must be switched via a module FX3-XTIO. To do so, a control output of the module FX3-XTIO (Q1 to Q4) must be connected with a control input of the relay module (B1, B2).

In addition, the feedback contacts Y1/Y2 on UE410-2RO and the feedback contacts Y1/Y2 and Y3/Y4 on relay module UE410-4RO must be connected with the FX3-XTIO.

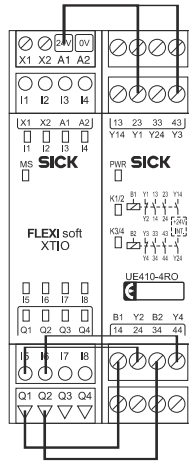

Figure 46: Example of integrating a relay module into the Flexi Soft system



WARNING

Limited safety without external device monitoring

The target safety-related level may not be achieved in the event of non-compliance.

- ▶ Monitor the feedback contacts using an EDM (external device monitoring) function block in the Flexi Soft logic editor.

5.3 Wiring for the power supply to a Flexi Soft system

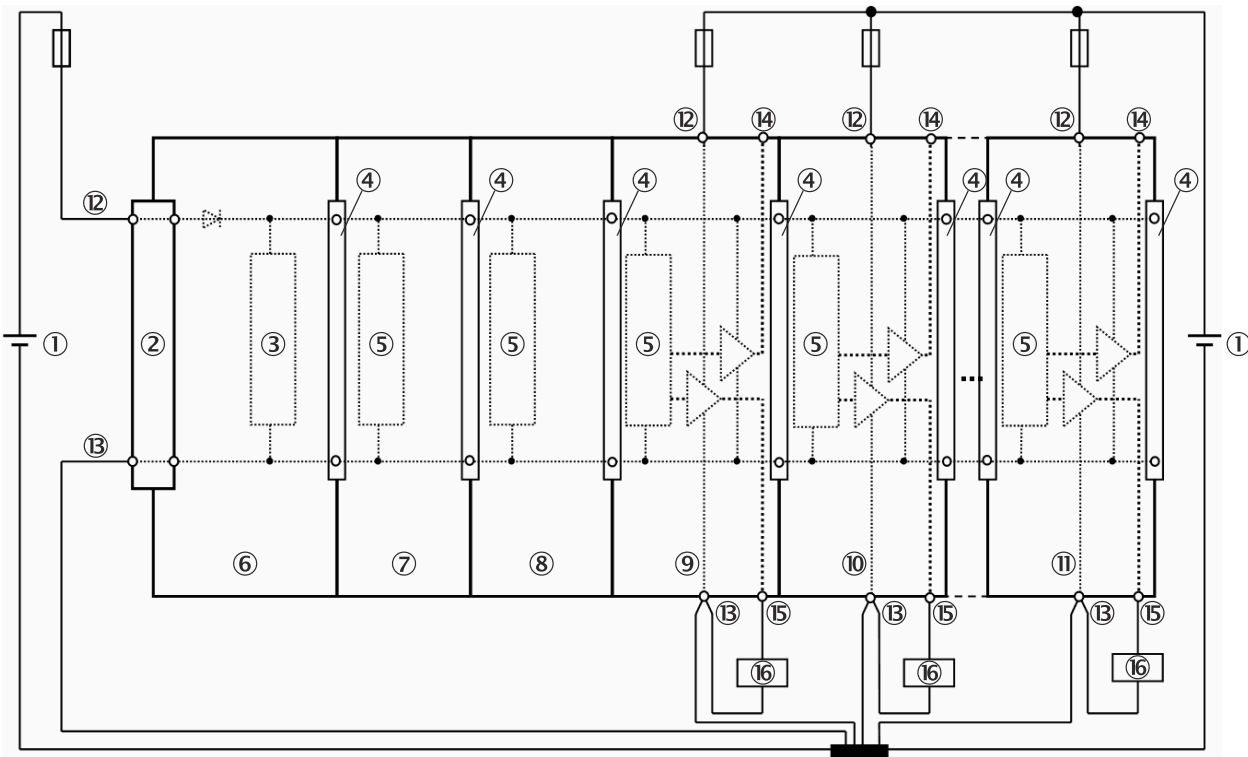

Figure 47: Wiring for the power supply to a Flexi Soft system

- ① 24 V DC
- ② System plug
- ③ Logic
- ④ FLEXBUS+
- ⑤ Application
- ⑥ Main module
- ⑦ Gateway 1
- ⑧ Gateway 2
- ⑨ Expansion module 1
- ⑩ Expansion module 2
- ⑪ Expansion module n
- ⑫ A1 (24 V)
- ⑬ A2 (GND)
- ⑭ Test outputs (X1 ... X8)
- ⑮ Outputs (Q1 ... Q4)
- ⑯ Actuator

5.4 Connection of devices

This section describes connecting safe and non-safe sensors, actuators and switching elements on the Flexi Soft system and provides mounting information on selected functions.

Sensors



WARNING

Ineffectiveness of the protective device due to unrecognized switching signals between the safety sensors

The dangerous state may not be stopped or not be stopped in a timely manner in the event of non-compliance.

- ▶ Select the minimum switch-off time of the connected sensors to be greater than the logic execution time of the Flexi Soft system. Observe the minimum switch-off time indicated in the technical data of the sensors.
 - ▶ Observe the safety notes and description of operation of the connected sensors. In case of doubt, contact the device manufacturer.
 - ▶ Observe the instructions on commissioning and daily thorough checking in the operating instructions of the connected sensors.
-

Single-channel inputs



WARNING

Ineffectiveness of the protective device due to unexpected pulses or delayed falling signal edges at single-channel inputs

The dangerous state may not be stopped or not be stopped in a timely manner in the event of non-compliance.

The target safety-related level may not be achieved in the event of non-compliance.

- ▶ Protect single-channel inputs against short-circuits and cross-circuits.
 - ▶ Make sure the signal line is laid with protection (to prevent a cross-circuit with other signal lines).
 - ▶ No short-circuit detection, i.e., no referencing to test outputs.
-

On a single-channel input with test pulses, which was previously in the low state, a short-circuit to high may be interpreted as a pulse by the logic due to the fault detection. The short-circuit to High causes the signal to switch to High and then back to Low at the end of the fault detection time. As a result, single-channel signals with test pulses require particular attention:

- If a short-circuit to High occurs on a single-channel input with test pulses and this was already in the High state, the logic interprets this signal as a delayed falling signal edge (High–Low).
- If a dangerous state could potentially arise because of an unexpected pulse or a delayed falling signal edge (High–Low) on a single-channel input, then concrete measures must be implemented.

This is particularly important in the case of the following inputs:

- **Reset** input on the reset function block
- **Restart** input on the restart function block
- **Restart** input on the function blocks for press applications
- **Override** input on the muting function blocks
- **Reset** input on a valve monitoring function block
- **Reset to zero** input and **Set to start value** on an event counter function block

Test outputs



WARNING

Ineffectiveness of the protective device due to incorrect connection of test outputs
The target safety-related level may not be achieved in the event of non-compliance.

- ▶ For each device to be tested, use a test output of the same module to which the device is connected.
- ▶ For devices connected to an odd-numbered input (I1, I3, I5, I7) use an odd-numbered test output (X1, X3, X5, X7, XY1). For devices connected to an even-numbered input (I12, I4, I6, I8) use an even-numbered test output (X2, X4, X6, X8, XY2).
- ▶ Observe the notes on using test pulses in the corresponding chapters of these operating instructions ("[FX3-XTIO I/O module](#)", page 24, "[FX3-XTDI I/O module](#)", page 28 and "[FX3-XTDS I/O module](#)", page 30).

5.4.1 Safety command devices and electro-mechanical safety switches

5.4.1.1 Emergency stop pushbutton (e.g., ES21)

Table 49: Connection for emergency stop pushbutton

| Electrical connection: example with FX3-XTIO | |
|--|--|
| Single-channel, at 24 V | Contact between 24 V and I1 |
| Single-channel, at test output | Contact between X2 and I2 |
| Dual-channel, at 24 V | Channel 1: contact between 24 V and I3 Channel 2: contact between 24 V and I4 |
| Dual-channel, at test output | Channel 1: contact between X1 and I5 Channel 2: contact between X2 and I6 |

The dual-channel emergency stop pushbuttons preconfigured in the configuration software have equivalent switching contacts. You will find suitable elements among the volt-free contacts for the implementation of dual-channel complementary switching contacts.

Table 50: Functions with ES21

| Function | Notes |
|-----------------------------|---|
| Tested | Possible |
| Series connection/cascading | If emergency stop pushbuttons are connected in series, the maximum conductor resistance must not exceed 100 Ω (see " Technical data ", page 132). |
| Discrepancy time | See the report in the configuration software |



NOTE

You will find more information in the operating instructions for the ES21 emergency stop pushbutton.

5.4.1.2 Electro-mechanical safety switches and locking devices

Table 51: Connection of electro-mechanical safety switches

| Electrical connection: example with FX3-XTIO | |
|--|--|
| Single-channel, at 24 V | Contact between 24 V and I1 |
| Single-channel, at test output | Contact between X2 and I2 |
| Dual-channel, at 24 V | Channel 1: contact between 24 V and I3 Channel 2: contact between 24 V and I4 |

| Electrical connection: example with FX3-XTIO | |
|--|--|
| Dual-channel, at test output | Channel 1: contact between X1 and I5 Channel 2: contact between X2 and I6 |

Table 52: Connection of locking devices

| Electrical connection: example with FX3-XTIO | |
|--|--|
| Single-channel, at 24 V | Contact between 24 V and I1 Coil at Q1 |
| Single-channel, at test output | Contact between X1 and I1 Coil at Q1 |
| Dual-channel, at 24 V | Channel 1: contact between 24 V and I1 Channel 2: contact between 24 V and I2 Coil at Q1 |
| Dual-channel, at test output | Channel 1: contact between X1 and I1 Channel 2: contact between X2 and I2 Coil at Q1 |

Table 53: Functions with electro-mechanical safety switches and locking devices

| Function | Notes |
|-----------------------------|---|
| Tested | Possible |
| Series connection/cascading | If safety switches are connected in series, the maximum conductor resistance must not exceed 100 Ω (see "Technical data", page 132). |
| Discrepancy time | See the report in the configuration software |

**NOTE**

You will find more information in the operating instructions for the electro-mechanical safety switches.

5.4.1.3 Enabling switch E100

Table 54: Connection of the E100

| Electrical connection: example with FX3-XTIO | |
|--|--|
| 2 positions, at 24 V | Channel 1: contact E31 between 24 V and I1 Channel 2: contact E41 between 24 V and I2 |
| 2 positions, at test output | Channel 1: contact E31 between X1 and I3 Channel 2: contact E41 between X2 and I4 |
| 3 positions, at 24 V | Channel 1: contact E13 between 24 V and I5 Channel 2: contact E23 between 24 V and I6 Channel 3: contact E31 between 24 V and I7 Channel 4: contact E41 between 24 V and I8 |
| 3 positions, at test output | Channel 1: contact E13 between 24 V and I1 Channel 2: contact E23 between 24 V and I2 Channel 3: contact E31 between X1 and I3 Channel 4: contact E41 between X2 and I4 |

Table 55: Functions with the E100

| Function | Notes |
|-------------------|--|
| Tested | Possible |
| Series connection | Not possible |
| Discrepancy time | See the report in the configuration software |



NOTE

You will find more information in the operating instructions for the enabling switch E100.

5.4.1.4 Two-hand control

Table 56: Connection of the two-hand control

| Electrical connection: example with FX3-XTIO | |
|--|--|
| Type IIIA, at 24 V | Channel 1: contact between 24 V and I1 Channel 2: contact between 24 V and I2 |
| Type IIIC, at 24 V | Channel 1: left-hand normally open between 24 V and I1 Channel 2: left-hand normally closed between 24 V and I2 Channel 3: right-hand normally open between 24 V and I3 Channel 4: right-hand normally closed between 24 V and I4 |

Type IIIA

With type IIIA, two equivalent inputs (N/O contacts for the 2 two-hand switches) are monitored.

A valid input signal is only generated if the ON state (High level) is present at both inputs within a period of 0.5 s (synchronous changeover, both two-hand switches actuated) and both were previously in the OFF state (Low level).

Table 57: Functions with type IIIA two-hand control

| Function | Notes |
|-----------------------------|--|
| Tested | Possible |
| Series connection/cascading | Not possible |
| Discrepancy time | Fixed preset value: 500 ms See function block for type IIIA two-hand in the logic of the main module, with which these outputs are to be evaluated. |

Type IIIC

With type IIIC, two pairs of complementary inputs (N/O contact / N/C contact pair) are monitored.

A valid input signal is only generated if the ON state (High/Low level) is present at both inputs within a period of 0.5 s (synchronous changeover, both two-hand switches actuated) and both were previously in the OFF state (Low/High level).

Table 58: Functions with type IIIC two-hand control

| Function | Notes |
|-----------------------------|--|
| Tested | Possible |
| Series connection/cascading | Not possible |
| Discrepancy time | Possible: 0–500 ms See function block for type IIIC two-hand in the logic of the main module, with which these outputs are to be evaluated. |
| Synchronization time | Fixed preset value: 500 ms See function block for type IIIC two-hand in the logic of the main module, with which these outputs are to be evaluated. |

5.4.1.5 Pressure-sensitive safety mats and bumpers

Table 59: Connection of pressure-sensitive safety mats and bumpers

| Electrical connection: example with FX3-XTIO | |
|--|--|
| Pressure-sensitive safety mat which triggers a short-circuit in 4-conductor technology, at test output | Channel 1: Connection between X1 and I1 Channel 2: Connection between X2 and I2 |

Table 60: Function of pressure-sensitive safety mats and bumpers

| Function | Notes |
|---|---|
| Parallel wiring | Possible |
| Number of safety mats or bumpers per FX3-XTIO, FX3-XTDI or FX3-XTDS | Max. 1 without diode module Max. 4 with diode module |



WARNING

Ineffectiveness of the protective device due to unrecognized switching signals between the safety sensors

The dangerous state may not be stopped or not be stopped in a timely manner in the event of non-compliance.

- Configure the test periods of the test outputs as shorter than the duration of the switch-off condition for the safety sensors.

5.4.1.6 Diode module DM8-A4K

The diode module DM8-A4K serves as a connection adapter when multiple pressure-sensitive safety mats that trigger short-circuits are connected to an FX3-XTIO or FX3-XTDI module. It decouples test outputs X1 and X2, thus increasing them fourfold.



NOTE

The DM8-A4K diode module is not a safety component in the sense of the Machinery Directive. It therefore does not have to be taken into account when calculating the safety integrity level (SIL according to IEC 61508 and IEC 62061) or the performance level (PL according to ISO 13849-1).

Electrical connection

Table 61: Connection of multiple pressure-sensitive safety mats with diode module DM8-A4K connected upstream

| Electrical connection: example with FX3-XTIO or FX3-XTDI | |
|---|---|
| Pressure-sensitive safety mat which triggers a short-circuit in 4-conductor technology, at test output and with diode module DM8-A4K connected upstream | Channel 1: Contact from X1 to I1 via diode Channel 2: Contact from X2 to I2 via diode Channels 3 to 8 as shown in the circuit diagram: see figure 48, page 84 |

Circuit diagrams

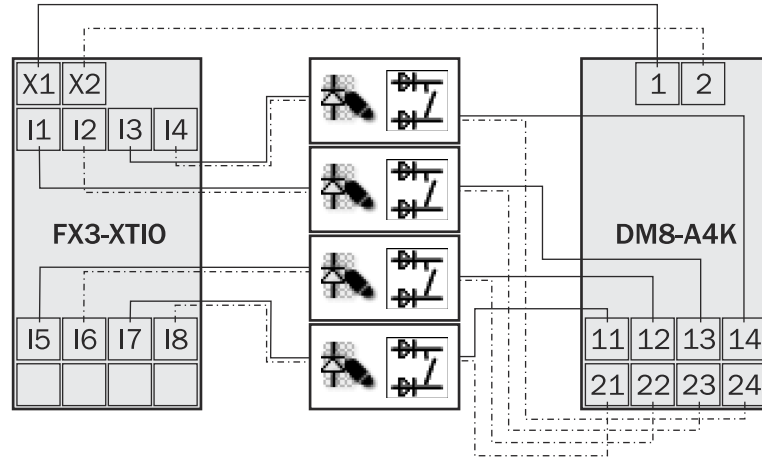

Figure 48: Circuit diagram for multiple pressure-sensitive safety mats with diode module DM8-A4K connected to the FX3-XTIO upstream

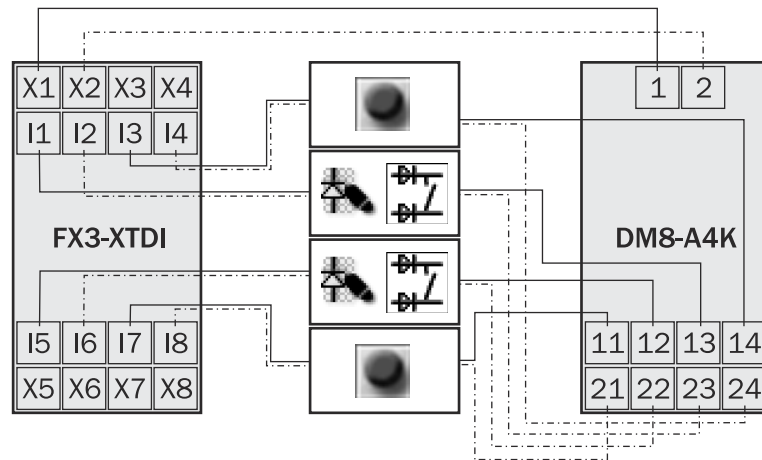

Figure 49: Circuit diagram for multiple pressure-sensitive safety mats with diode module DM8-A4K connected to the FX3-XTDI upstream



NOTE

Instead of a pressure-sensitive safety mat, you can also connect a safety switch or an emergency stop pushbutton, for example (see figure 49, page 84).

Internal circuitry for diode module DM8-A4K

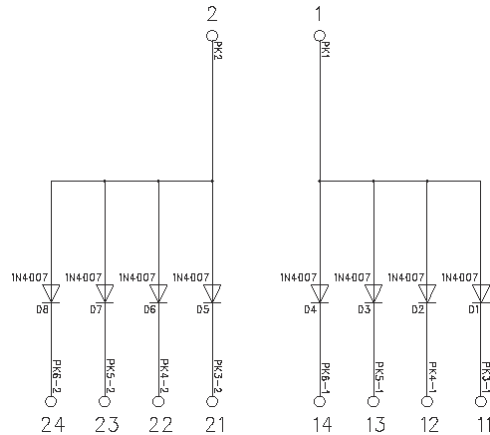

Figure 50: Internal circuitry for diode module DM8-A4K

5.4.1.7 Operating mode selector switch

Table 62: Connection of operating mode selector switch

| Electrical connection: example with FX3-XTIO | |
|---|--|
| Operating mode selector switch (1 of 2), at 24 V | Channel 1: contact between 24 V and I1 Channel 2: contact between 24 V and I2 |
| Operating mode selector switch (1 of 2), at test output | Channel 1: contact between X1 and I1 Channel 2: contact between X1 and I3 |

Table 63: Function with operating mode selector switch

| Function | Notes |
|----------|----------|
| Tested | Possible |



NOTE

- Operating mode selector switches without test signals support between 2 and 8 operating modes; operating mode selector switches with test signals support between 2 and 4 operating modes.
- When wiring the tested operating mode selector switch, please remember that if you are using a test output with an odd number (X1, X3, X5, X7), inputs with odd numbers (I1, I3, I5, I7) must be used; if you are using a test output with an even number (X2, X4, X6, X8), inputs with even numbers (I2, I4, I6, I8) must be used.
- You will find more information in the operating instructions for the operating mode selector switches.

5.4.1.8 Volt-free contacts

The configuration software provides a range of volt-free contacts for “free” arrangement of contact elements. This enables a variety of N/C / N/O combinations to be implemented with and without testing. There are also start and stop button, reset button, and external device monitoring (EDM) elements available.

Table 64: Functions with volt-free contacts

| Function | Notes |
|-------------------|--|
| Tested | Possible |
| Series connection | Possible |
| Discrepancy time | See the report in the configuration software |

5.4.2 Non-contact safety switches

5.4.2.1 Magnetic safety switches (e.g., RE)

Table 65: Connection of magnetic safety switches with equivalent inputs (RE13, RE27)

| Electrical connection: example with FX3-XTIO | |
|--|--|
| At test output | Channel 1: contact between X1 and I1 Channel 2: contact between X2 and I2 |

Table 66: Connection of magnetic safety switches with complementary inputs (e.g., RE11, RE21, RE31, RE300)

| Electrical connection: example with FX3-XTIO | |
|--|--|
| At test output | N/C contact between X1 and I3 N/O contact between X2 and I4 |

Table 67: Functions with magnetic safety switches

| Function | Notes |
|-----------------------------|--|
| Tested | Possible |
| Series connection/cascading | Possible; note max. conductor resistance of 100 Ω and ensure test signal time is set correctly |
| Discrepancy time | Pre-setting: 1.5 s, see the report in the configuration software |



NOTE

You will find more information in the operating instructions for the magnetic safety switches.

5.4.2.2 Inductive safety switches IN4000 and IN4000 Direct

Table 68: Connection of inductive safety switches

| Electrical connection: example with FX3-XTIO | |
|--|---|
| IN4000 | Test input TI (IN4000) at X1 Output Q (IN4000) at I1 |
| IN4000 Direct (with OSSD) | OSSD1 (IN4000) at I3 OSSD2 (IN4000) at I4 |

Table 69: Functions with inductive safety switches

| Function | Notes |
|-----------------------------|--|
| Tested | Necessary on the IN4000 |
| Series connection/cascading | IN4000 Direct cannot be cascaded IN4000 : up to 6 sensors per input Maximum switch-on delay of the cascade: 10 ms (otherwise the test pulse width leads to shutdown) Note max. conductor resistance of 100 Ω and ensure test signal time is set correctly |



NOTE

You will find more information in the operating instructions for the inductive safety switches.

5.4.2.3 Transponders T4000 Compact and T4000 Direct

Table 70: Connection of the transponders

| Electrical connection: example with FX3-XTIO | |
|--|--|
| T4000 Compact (at 24 V) | 24 V at +LA, I1 at LA 24 V at +LB, I2 at LB |
| T4000 Compact (at test output) | X1 at +LA, I3 at LA X2 at +LB, I4 at LB |
| T4000 Direct (with OSSD) | 24 V at UB (T4000), I5 at OA 24 V at UB (T4000), I6 at OB |

Table 71: Functions with transponders

| Function | Notes |
|-----------------------------|--|
| Tested | Possible for T4000 Compact Not necessary for the T4000 Direct, as self-monitoring |
| Series connection/cascading | T4000 Compact cannot be cascaded T4000 Direct: Please note the maximum conductor resistance of 100 Ω (see "Technical data", page 132). |



NOTE

You will find more information in the operating instructions for the T4000 Compact and T4000 Direct transponders.

5.4.3 Testable safety single-beam sensors

5.4.3.1 Testable type 2 safety single-beam sensors

Table 72: Connection of testable type 2 safety single-beam sensors

| Electrical connection: example with FX3-XTIO | |
|--|---|
| Wx12/24/27, Vx18 | Test input TI (sender) at X1 Output Q (receiver) at I1 |
| L21, L27/L28 | Test input TI (sender) at X2 Output Q (receiver) at I2 |



WARNING

Impairment of fault detection due to cross-circuit

The dangerous state may not be stopped or not be stopped in a timely manner in the event of non-compliance.

- ▶ Prevent cross-circuits between the connection from the test output of the Flexi Soft module to the test input of the sender and the connection from the output of the receiver to the safe input of the Flexi Soft module with protected or separate cabling.

Table 73: Functions with testable type 2 safety single-beam sensors

| Function | Notes |
|-----------------------------|--|
| Tested | Possible |
| Series connection/cascading | <p>Wx12/24/27, Vx18:</p> <ul style="list-style-type: none"> Maximum 2 pairs per input can be cascaded with test pulse width = 4 ms (standard element in the configuration software) Maximum 5 pairs per input can be cascaded with test pulse width = 12 ms (user-defined element required in configuration software) <p>L21:</p> <ul style="list-style-type: none"> Maximum 10 pairs per input can be cascaded with test pulse width = 4 ms (standard element in the configuration software) Maximum 25 pairs per input can be cascaded with test pulse width = 8 ms (user-defined element required in configuration software) <p>L27/L28:</p> <ul style="list-style-type: none"> Maximum 7 pairs per input can be cascaded with test pulse width = 4 ms (standard element in the configuration software) Maximum 18 pairs per input can be cascaded with test pulse width = 12 ms (user-defined element required in configuration software) <p>► Observe max. conductor resistance of 100 Ω.</p> |



NOTE

For more information, please refer to the operating instructions for the testable type 2 safety single-beam sensors.

5.4.3.2 Testable type 4 safety single-beam sensors

Table 74: Connection of testable type 4 safety single-beam sensors

| Electrical connection: example with FX3-XTIO | |
|--|---|
| L41 | Test input TI (sender) at X1 Output Q (receiver) at I1 |



WARNING

Impairment of fault detection due to cross-circuit

The dangerous state may not be stopped or not be stopped in a timely manner in the event of non-compliance.

- Prevent cross-circuits between the connection from the test output of the Flexi Soft module to the test input of the sender and the connection from the output of the receiver to the safe input of the Flexi Soft module with protected or separate cabling.

Table 75: Functions with testable type 4 safety single-beam sensors

| Function | Notes |
|-----------------------------|--|
| Tested | Necessary |
| Series connection/cascading | <p>L41:</p> <ul style="list-style-type: none"> Maximum 10 pairs per input can be cascaded with test pulse width = 4 ms (standard element in the configuration software) Maximum 25 pairs per input can be cascaded with test pulse width = 8 ms (user-defined element required in configuration software) <p>Note the maximum conductor resistance of 100 Ω.</p> |

**NOTE**

For more information, please refer to the operating instructions for the testable type 4 safety single-beam sensors.

5.4.3.3 User-defined testable safety single-beam sensors

For information on creating customized elements, please refer to the “Flexi Soft in the Flexi Soft Designer Configuration Software” and “Flexi Soft in the Safety Designer Configuration Software” operating instructions.

**NOTE**

- Configure the user-defined element in the configuration software for the Flexi Soft system with the minimum value for the desired test pulse width.
- Regardless of the test pulse width, the overall switch-on delay of the cascade must be smaller than the maximum switch-on delay of the respective test output (as shown in the configuration software report) - 2 ms. Otherwise the test pulse width will lead to switching off. For FX3-XTIO or FX3-XTDI modules, this value = 12 ms - 2 ms = 10 ms.

**WARNING**

Impairment of fault detection due to cross-circuit

The dangerous state may not be stopped or not be stopped in a timely manner in the event of non-compliance.

- ▶ Prevent cross-circuits between the connection from the test output of the Flexi Soft module to the test input of the sender and the connection from the output of the receiver to the safe input of the Flexi Soft module with protected or separate cabling.

5.4.3.4 Instructions for mounting the testable safety single-beam sensors

**WARNING**

Ineffectiveness of the protective device due to improper mounting or improper use

The dangerous state may not be stopped or not be stopped in a timely manner in the event of non-compliance.

The target safety-related level may not be achieved in the event of non-compliance.

- ▶ Use safety single-beam sensors only as access protection as per EN ISO 13855.
- ▶ Do not use safety single-beam sensors as finger and hand protection.
- ▶ Complying with the minimum distance to reflective surfaces.
- ▶ Comply with the safety distance between the light beam and hazardous point for access protection.
- ▶ Observe the operating instructions of each sensor.

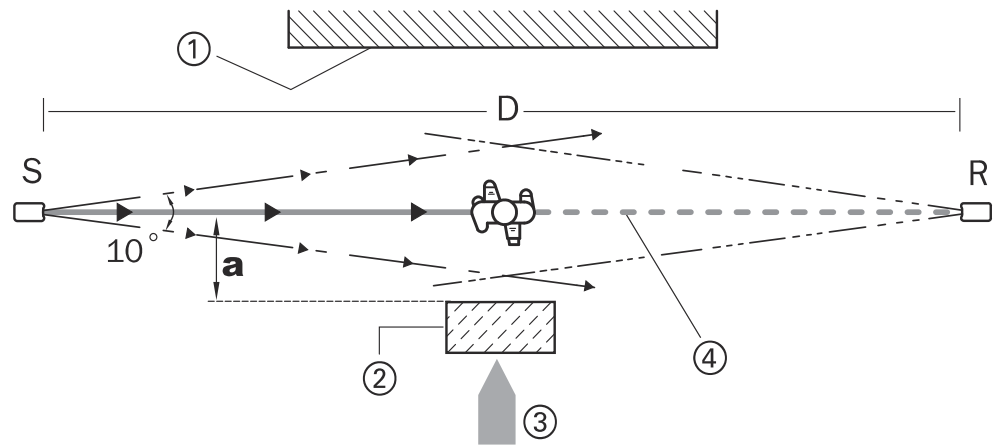

Figure 51: Minimum distance a to reflective surfaces, correct mounting and alignment

- S: Sender
- R: Receiver
- D: Distance between sender and receiver
- a : Minimum distance to reflective surface
- ①: Limit to hazardous area
- ②: Reflective surface
- ③: Entry direction to hazardous area
- ④: Optical axis

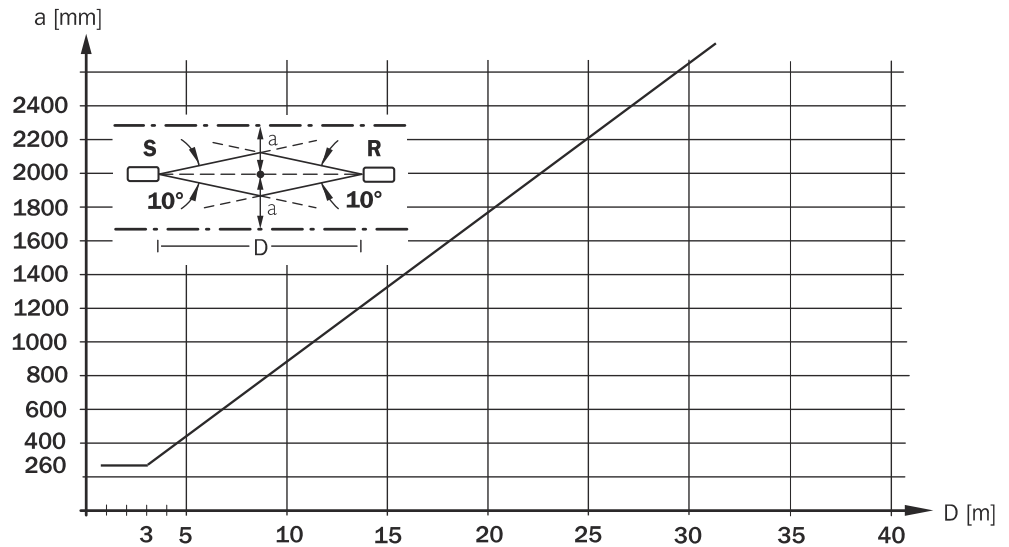

Figure 52: Minimum distance a as a function of distance D for testable safety single-beam sensors with aperture angle 10° (e.g. Wx12/24/27, Vx18)



NOTE

Each set of operating instructions contains the diagrams for L21, L27/L28 and L41.

**WARNING**

Ineffectiveness of the protective device due to mutual optical interference

If several safety single-beam sensors pairs are used:

- ▶ Observe the aperture angle of the sensors to exclude mutual optical interference.
- ▶ Ensure that the light beam from each sender only reaches the associated receiver. To do so, mutual mounting (among other things) of the sender and receiver can be required between the sender and receiver.

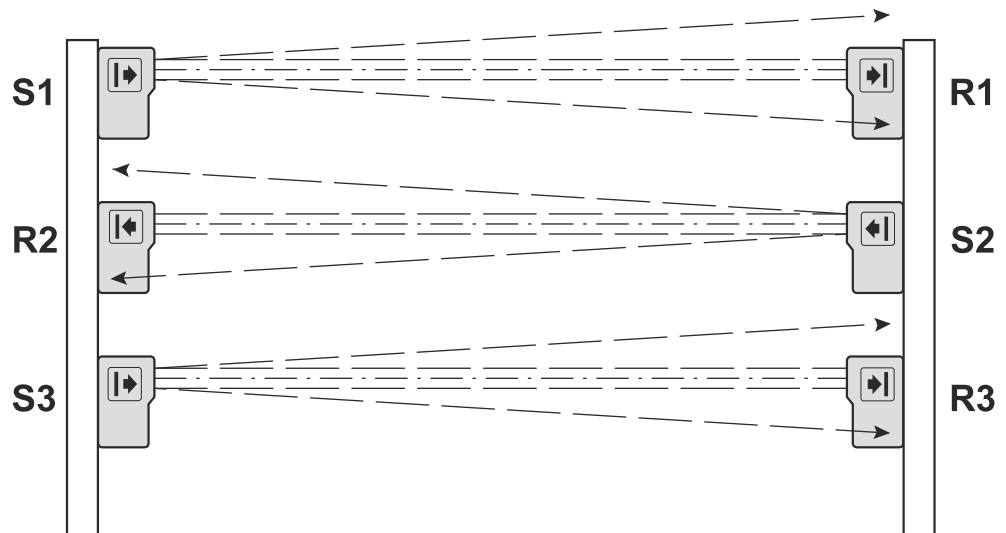

Figure 53: Mutual mounting to avoid mutual optical interference

5.4.4 Electro-sensitive protective devices

Table 76: Connection of electro-sensitive protective devices

| Electrical connection: example with FX3-XTIO | |
|---|--|
| C2000, C4000, M2000, M4000, S300, S3000, V300, miniTwin | OSSD1 (receiver) at I1 OSSD2 (receiver) at I2 |

**NOTE**

You will find more information in the operating instructions for the corresponding electro-sensitive protective devices.

5.4.5 Safety outputs Q1 to Q4

Important information

**WARNING**

Ineffectiveness of the protective device due to unintended switching of actuators

The dangerous state may not be stopped or not be stopped in a timely manner in the event of non-compliance.

- ▶ Connect the GND connections of the actuators to the outputs Q1 to Q4 in star formation with the GND connection of the voltage supply.

**NOTICE**

Exceeding the nominal values at the outputs

The device may be damaged if this is not observed.

- ▶ Do not connect any loads that exceed the nominal values of the outputs Q1 to Q4.

Connection example

The following example shows the connection of an FX3-XTIO I/O module to an OSSD1 safety relay. Due to the protected cable laying, SIL3 can be achieved with a single-channel output.

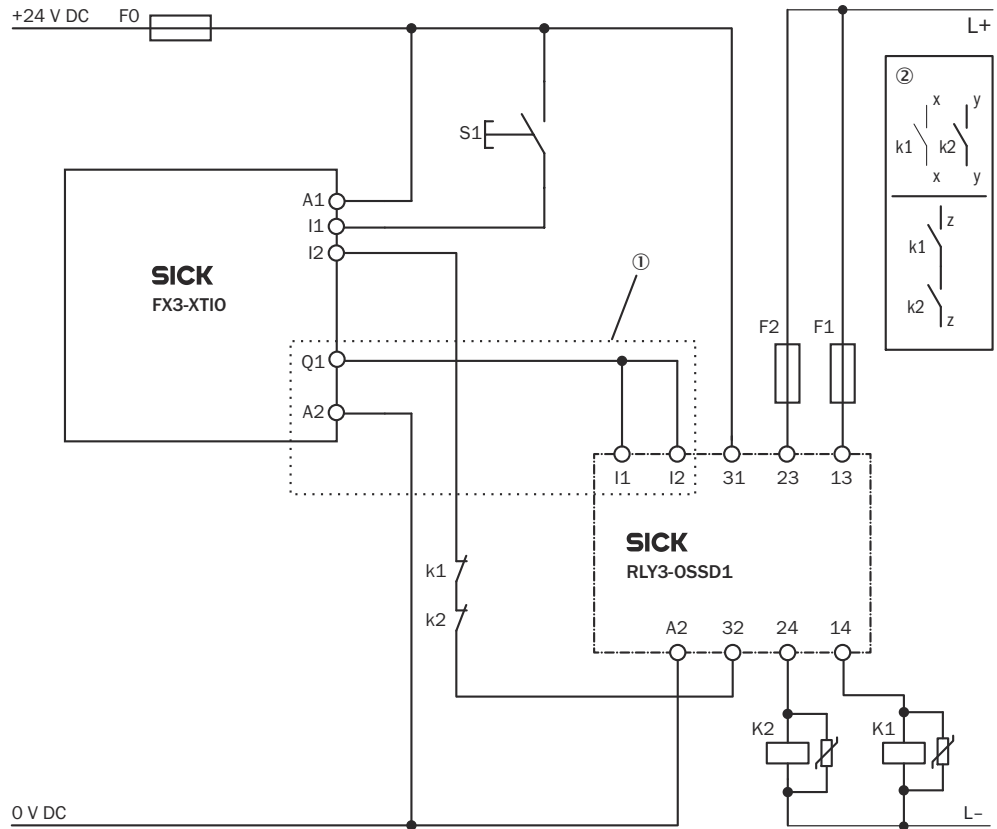

Figure 54: Example for the connection of an FX3-XTIO I/O module to a OSSD1 safety relay

- ① Required for SIL3 protected cable laying
- ② Output circuits: These contacts must be incorporated into the control such that the dangerous state is brought to an end if the output circuit is open. For categories 4 and 3, they must be incorporated on dual channels (x, y paths). Single-channel incorporation into the controller (z path) is only possible with a single-channel controller and taking the risk analysis into account.

5.4.6 Connection of EFI-enabled devices

If the Flexi Soft system contains a FX3-CPU1 main module or higher, the EFI-capable devices and sensors from SICK can be connected to it.



NOTICE

Overvoltage at the EFI inputs

The device may be damaged if this is not observed.

- ▶ Connect the main module and all EFI-capable devices connected to it with the same GND connection of the voltage supply.
- ▶ Observe the maximum permissible voltage of ± 30 V (to terminal A2 = GND) at the EFI inputs.

**NOTE**

- If shielding is required to connect the EFI-capable devices e.g. due to EMC reasons, then an additional ground terminal must be used. Place this ground terminal in the control cabinet near the Flexi Soft main module and connect with the shielding.
- No external terminator is required for the EFI connections on the main module.

For information on connecting EFI-capable devices incl. the pin assignment, see the operating instructions of the corresponding device.

Cables

SICK offers two different EFI cables for connecting EFI-capable devices (see ["Accessories for the safety controller"](#), page 184). For more information, refer to the operating instructions of each EFI-capable device.

EMC measures

To increase the EMC of the EFI communication, it is important to connect the shielding of the EFI cable with the functional earth on one or both sides.

- ▶ Connect the shielding with the same DIN mounting rail that the functional earth (FE) of the Flexi Soft system is connected with to minimize faults on the EFI cable. Earthing the shielding should be done near the cable entry in the control cabinet.

**NOTE**

- The FE terminal of the Flexi Soft system is located on the rear of the housing. It is connected automatically when mounted on the DIN mounting rail.
- To avoid further interference, the functional earth for the SICK sensors (e.g., M4000, S3000) must also be connected to the shielding of the EFI cable.
- If further cables that may be faulty (e.g. for drives or motors) are used in the same cable channel as the EFI cable, this can lead to availability issues. For this reason, we recommend using the EFI cable in a separate cable channel.

5.4.7 Connection of a Pro-face HMI

You can connect an HMI manufactured by Pro-face to the RS-232 interface of the Flexi Soft main modules. Suitable cables: see ["Accessories for the safety controller"](#), page 184.

**NOTE**

To enable communication between the Flexi Soft system and the Pro-face-HMI, you must activate RS-232 routing for the main module (see "Flexi Soft in the Flexi Soft Designer Configuration Software" or "Flexi Soft in the Safety Designer Configuration Software" operating instructions).

Information on the configuration of data exchanged via the RS-232 interface as well as via export of tag names from the configuration software for use with a pro-face HMI can be found in the "Flexi Soft in the Flexi Soft Designer Configuration Software" and "Flexi Soft in the Safety Designer Configuration Software" operating instructions.

You will find information about replacing a suitable device, about connection, and about programming, in the "GP-Pro EX Device/PLC Connection Manual" operating instructions which are both available directly from Pro-face and can be downloaded from www.pro-face.com.

You can download the driver for the Pro-face devices for connection to the Flexi Soft main modules from www.pro-face.com.

You will find more information about communicating with the Flexi Soft system via the RS-232 interface in the “Flexi Soft RK512 Telegram Listing” online help (SICK part number 8015053).

5.4.8 Connection of encoders

The following encoder types can be connected to an FX3-MOCx:

- A/B incremental encoders HTL 24 V, HTL 12 V, TTL, max. 300 kHz
- A/B incremental encoder RS-422, max. 1 MHz ⁶⁾
- Sine-cosine encoder 1 V_{pp}, max. 120 kHz
- SSI encoder, RS-422, max. 1 MBaud



WARNING

Ineffectiveness of the protective device due to selection of an unsuitable encoder
The target safety-related level may not be achieved in the event of non-compliance.

- ▶ Select a suitable encoder.
- ▶ Take suitable measures against the encoder's systematic errors and common causes of error.

Choosing the right encoder is crucial to achieving the desired safety integrity level (SIL) and performance level (PL). Systematic errors and common cause errors (CCF), in particular, need to be minimized in this case.

More information on selecting the encoder and on measures against common fault causes: see ["Motion Control FX3-MOC0", page 34](#) and ["Motion Control FX3-MOC1", page 36](#).



NOTE

The wiring plan for the selected configuration of the encoder is a component of the report for the configuration software.

- ▶ Observe the selection options for the connection type of the encoder in the configuration software.



NOTE

- Connection or pin assignment of the encoder:
 - ["Encoder/motor feedback connection units", page 62](#)
 - ["Encoder connection cables", page 71](#).
 - We recommend using the connection cables and encoder/motor feedback connection boxes that are available as accessories (see ["Accessories for the safety controller", page 184](#)).
-

⁶⁾ Only possible for encoder 1 (ENC1).

Table 77: Facilities for connecting encoders

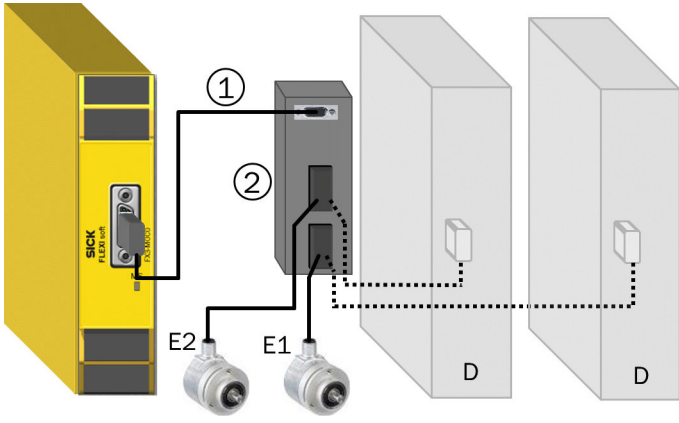
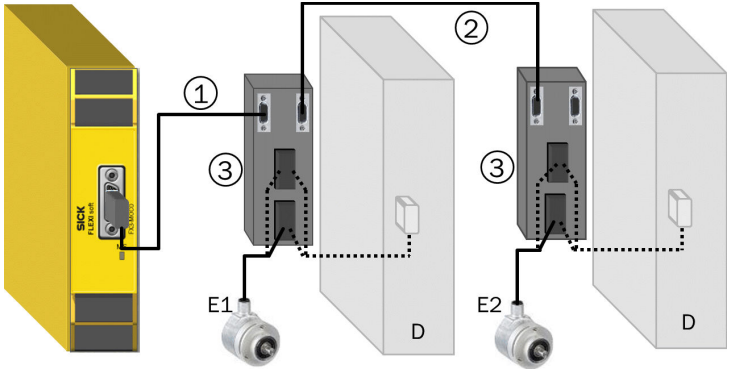
| | |
|---|--|
| <p>Connection to an optimized dual encoder/motor feedback connection box FX3-EBX1</p> |  <p>E1 Encoder 1 E2 Encoder 2 D PLC/drive controller ① Connection cable between the FX3-MOCx and an encoder/motor feedback connection box (SICK part number 2067798, 2067799, 2077261, or 2077262) ② Optimized dual encoder/motor feedback connection box FX3-EBX1 (SICK part number 2079867)</p> |
| <p>Connection to two encoder/motor feedback connection boxes FX3-EBX3</p> |  <p>E1 Encoder 1 E2 Encoder 2 D PLC/drive control ① Connection cable between the FX3-MOCx and an encoder/motor feedback connection box (SICK part number 2067798, 2067799, 2077261, or 2077262) ② Connection cable for FX3-EBX3 and FX3-EBX4 (SICK part number 2078260, 2067800, or 2067801) ③ Encoder/motor feedback connection box FX3-EBX3 (SICK part number 2068728)</p> |

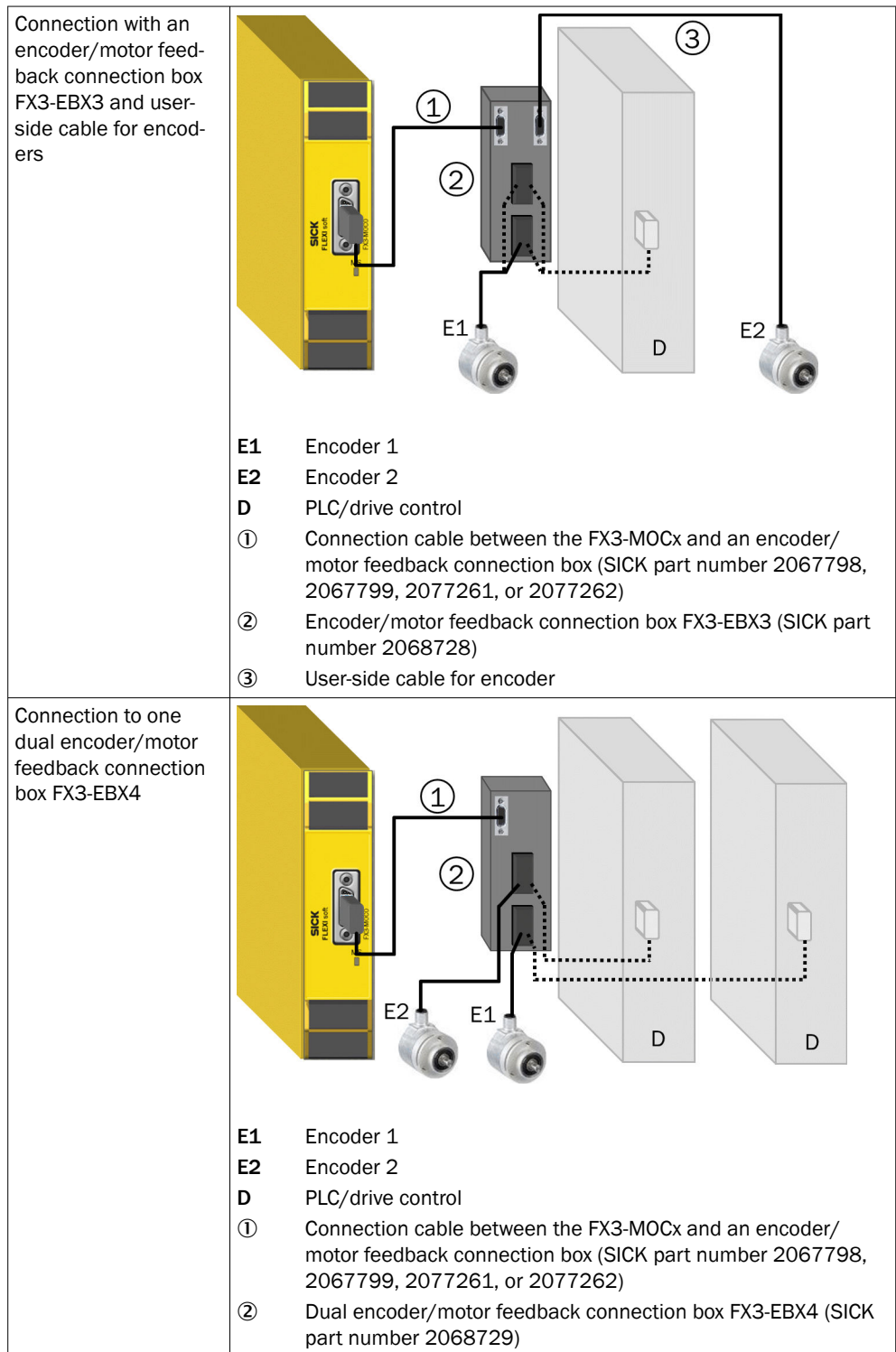

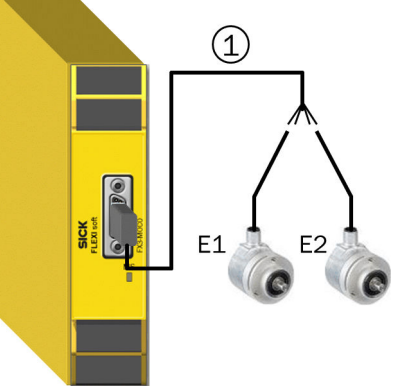
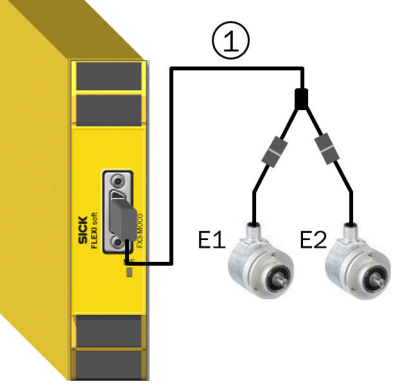
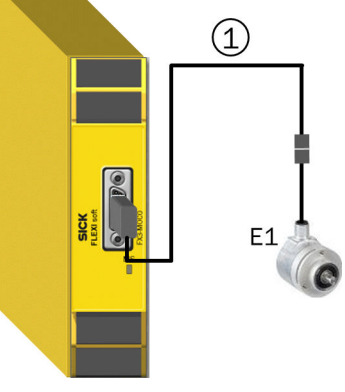
| | |
|--|--|
| <p>Connection with connection cable for direct encoder connection, open cable end</p> |  <p>E1 Encoder 1 E2 Encoder 2 ① Connection cable for direct connection of two encoders, open cable end (SICK part number 2067893 or 2077263)</p> |
| <p>Connection with connection cable for direct encoder connection, 2× M12</p> |  <p>E1 Encoder 1 E2 Encoder 2 ① Connection cable for direct connection of two encoders, 2× M12 (SICK part number 2094381)</p> |
| <p>Connection with connection cable for direct encoder connection, chosen from the following:</p> <ul style="list-style-type: none"> • 1× M12, 8-pin (e.g., for DFS60S Pro) • 1× M12, 12-pin (e.g., for SSI + sine-cosine) |  <p>E1 Encoder 1 ① Connection cable for direct connection of one encoder, 1× M12, 8-pin (SICK part number 2094403, 2094426, 2094427, or 2094428) or 1× M12, 12-pin (SICK part number 2094372, 2094434, 2094435, or 2094436)</p> |



NOTE

Where encoders with two outputs are concerned, inputs A- and B- on the FX3-MOCx must not remain open; they must be connected to 0 V. In this case, the connection must be as close as possible to the 0 V encoder connection.

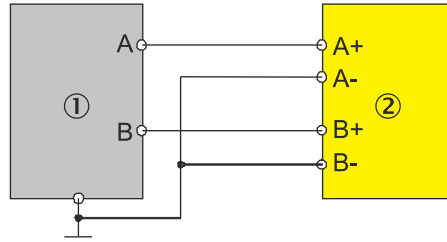

Figure 55: Connection of A/B incremental encoders with two outputs

- ① A/B incremental encoder with two outputs
- ② FX3-MOCx

24 V are available at the encoder connection of the FX3-MOC0 module for the encoder voltage supply. A selectable supply voltage is available at the encoder/motor feed-back connection boxes. Details:

- see "Encoder/motor feedback connection units", page 62
- see "Motion Control MOC0", page 156 (technical data)
- see "Motion Control MOC1", page 161 (technical data)
- see "EBX1, EBX3 and EBX4 encoder/motor feedback connection units", page 167 (technical data)

5.4.9 Connecting analog sensors

Two analog sensors can be connected to the FX3-ANA0 analog input module in order to measure a joint process variable. The analog input module has two analog inputs, which are continually compared with one another.

Only sensors with a standardized current interface in accordance with EN 61131-2 5.3.1 and with a signal strength of 4 to 20 mA can be connected and evaluated.



NOTICE

Exceeding the limit values at the inputs

The device may be damaged if this is not observed.

- ▶ Observe the limit values for the inputs (30 V DC / 30 mA).
- ▶ Only use suitable sensors.

The AI1 sensor input consists of pins 1+ and 1-. The AI2 sensor input consists of pins 2+ and 2-.



NOTE

The FX3-ANA0 can detect a sensor connection with reverse polarity (I1+ switched with I1- or I2+ switched with I2-) as an error.

If only one individual sensor is used for a process variable, this sensor must be connected in series to both inputs; see figure 57.

Sensor connection cables

The FX3-ANA0 analog input module has no shielding connections. If shielding is required for connecting the sensors – for reasons of electromagnetic compatibility, for example – the shield must be connected using a ground terminal that is positioned in the control cabinet close to the Flexi Soft main module.

**NOTE**

Connected sensors are not supplied by the FX3-ANA0. They require an external power supply unit.

Connection examples

Figure 56: Connection of non-safe single-channel analog signal transmitters

Left: Connection example

Right: As illustrated in Flexi Soft Designer

**WARNING**

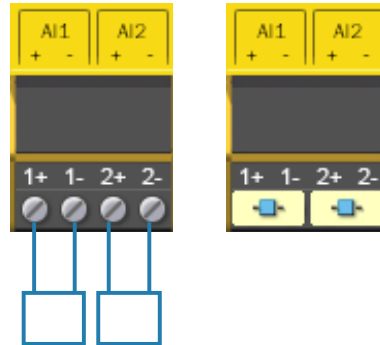
Ineffectiveness of the protective device due to improper connection

The target safety-related level may not be achieved in the event of non-compliance.

- ▶ When using a safe single-channel analog signal transmitter, install a bridge between the connections AI1- and AI2+, see figure 57.

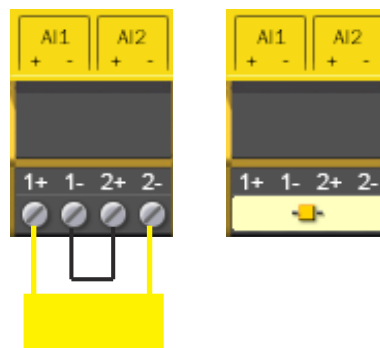

Figure 57: Connection of a safe single-channel analog signal transmitter

Left: Connection example

Right: As illustrated in Flexi Soft Designer

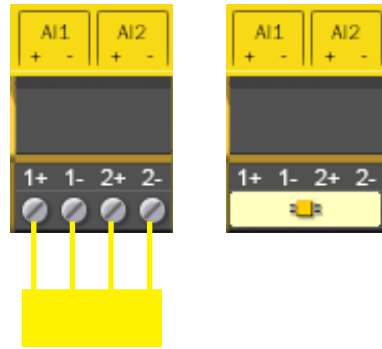

Figure 58: Connection of a safe dual-channel analog signal transmitter

Left: Connection example

Right: As illustrated in Flexi Soft Designer

Connecting the sensors to a second control

The FX3-ANA0 inputs are configured in such a way that a second control (connected in series) can use the measured values of the sensors as well.



WARNING

Influence of the signals of the FX3-ANA0 due to the memorized fault current of a second control

The dangerous state may not be stopped or not be stopped in a timely manner in the event of non-compliance.

The target safety-related level may not be achieved in the event of non-compliance.

- ▶ Carry out the corresponding safety assessment and validation, taking into account this possible source of error.

5.4.10 Connecting Flexi-Link system

Overview

There are two ways to connect a Flexi Link system:

- Connection via EFI1 (26 bits)
- Connection via EFI1+2 (52 bits)

Important information



WARNING

Limited safety due to buffering elements

The target safety-related level may not be achieved in the event of non-compliance.

- ▶ In a Flexi Link system, do not use buffering elements such as CAN bridges, CAN repeaters or CAN-capable optical photoelectric sensors.
- ▶ Do not use any other components except for Flexi Link stations in a Flexi Link system.



NOTICE

Overvoltage at the EFI inputs

The device may be damaged if this is not observed.

- ▶ Observe the maximum permissible voltage at the EFI inputs of ± 30 V (to terminal A2 = GND).

Procedure

1. Connect the identically named terminals with each other (e.g. EFI1_A at station A with EFI1_A at station B etc.).

0 V DC

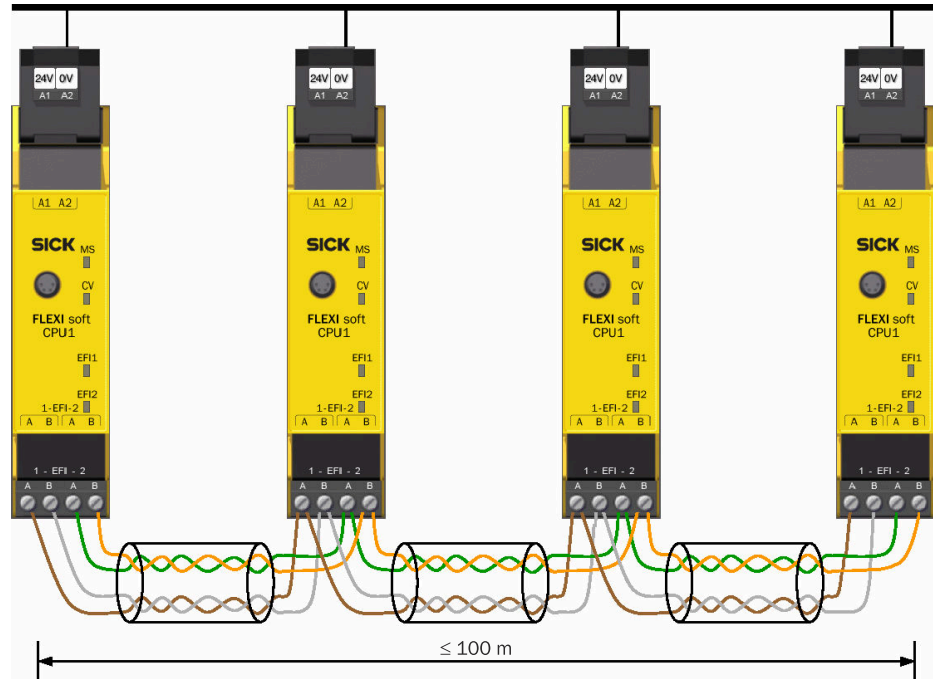

Figure 59: Connecting Flexi-Link stations via EFI1+2

2. Connect not used cables to the functional earth (FE) at both ends.
3. Connect all connected Flexi Link stations with the same GND connection of the voltage supply (terminal A2 on the system plug).

Complementary information

Connection:

- No external terminator is required for the EFI connections on the main module.
- Stub cables or star-shaped wiring are not allowed.
- The maximum permissible total length of the cables for EFI1 and EFI2 (all stations) is 100 m each.

Flexi-Link cables:

- Flexi-Link stations can be connected using CAN cables (shielded, twisted pair).
Table 78: Possible lengths of cable and types for Flexi-Link connections

| Length of cable | Cable type |
|-----------------|---------------------------------------|
| Up to 40 m | 2 × 2 × 0.25 mm ² (AWG 23) |
| Up to 100 m | 2 × 2 × 0.34 mm ² (AWG 22) |

- SICK offers a suitable cable for connections up to 100 m (SICK part number 6034249, 2 × 2 × 0.34 mm², sold by the meter, see ["Accessories for the safety controller"](#), page 184).

Further topics

- ["EMC measures for Flexi Link and Flexi Line"](#), page 103

5.4.11 Connecting Flexi-Line system

Important information



WARNING

Limited safety due to buffering elements

The target safety-related level may not be achieved in the event of non-compliance.

- ▶ Do not use any buffering elements in a Flexi Line system, such as CAN bridges, CAN repeaters or CAN-capable optical photoelectric sensors.
- ▶ Do not use any other components except Flexi Line stations in a Flexi Link system.



NOTICE

Overvoltage at the Flexi Line inputs

The device may be damaged if this is not observed.

- ▶ Observe the maximum permissible voltage at the Flexi Line inputs of ± 30 V (to terminal A2 = GND).

Procedure

1. Connect the **NEXT** connection of each station to the **PRE** connection of the next station.
2. Connect the identically named terminals with one another, i.e. **A** with **A** and **B** with **B**.



Figure 60: Connection of a Flexi-Line system

3. Connect not used cables to the functional earth (FE) at both ends.

Complementary information

Connection:

- No external terminator is required for the Flexi Line connections on the main module.
- Stub cables or star-shaped wiring are not allowed.
- The maximum permissible total length between two Flexi-Line stations is 1,000 m.

Flexi-Line cables

- Flexi-Line stations can be connected using CAN cables (shielded, twisted pair).

Table 79: Possible lengths of cable and types for Flexi Line connections

| Length of cable | Cable type |
|-----------------|-----------------------------------|
| Up to 40 m | 2 × 0.22 mm ² (AWG 23) |

| Length of cable | Cable type |
|-----------------|-----------------------------------|
| Up to 125 m | 2 × 0.34 mm ² (AWG 22) |
| Up to 1,000 m | 2 × 0.75 mm ² (AWG 18) |

- SICK offers a suitable cable for connections up to 40 m (SICK part number 6029448, 2 × 0.22 mm², sold by the meter, see "Accessories for the safety controller", page 184).

Further topics

- "EMC measures for Flexi Link and Flexi Line", page 103

5.4.12 EMC measures for Flexi Link and Flexi Line

Flexi Link and Flexi Line cables are used for the transmission of communication signals. Electromagnetic interference can disrupt signal transmission and interrupt communication. The following measures are necessary to minimize electromagnetic interference:

- ▶ Ensure sufficient equipotential bonding of the connection points for the shielding. In doing so, follow the applicable standards and directives.
- ▶ Connect all inactive metal parts (doors and housing of the control cabinet, DIN mounting rails, etc.) to the ground potential.
- ▶ Always connect the cable shielding to the ground connection across a large area at both ends.
- ▶ Use suitable cable clamps to connect the shielding of the shielded cables to the ground potential directly at the access to the system (control cabinet, frame, DIN mounting rail). The cable clamps must reach all the way around the cable shielding.
- ▶ Use suitable cable clamps to connect the cable shielding to the ground potential, **once again** as close as possible to the main module (e.g. on the DIN mounting rail). The cable clamps must reach all the way around the cable shielding.

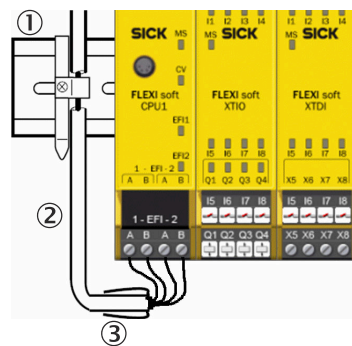

Figure 61: Connect the cable shielding to the DIN mounting rail

- ① DIN mounting rail
- ② Cable
- ③ Heat-shrinkable sleeve

- ▶ Keep the cable ends from which the insulation has been stripped as short as possible.
- ▶ Insulate the end of the shielding braid, for example using a suitable heat-shrinkable sleeve.



NOTE

- All connections must conduct electricity effectively with low electrical impedance. Stub cables or star-shaped wiring are not allowed.
 - Load cables (e.g., for frequency inverters, electronic speed controllers, contactors, brakes, etc.) and small-signal cables (e.g., measuring cables, analog sensors, fieldbus cables, etc.) must be laid separately and with low-induction coupling.
-

6 Configuration

6.1 Configuration

Configuration of the safety controller



NOTE

The Flexi Soft Designer configuration software or Safety Designer configuration software as well as a FX3-MPL0 or FX3-MPL1 system plug is required for configuration.

- The system configuration for the entire Flexi Soft system (with exception of the configuration of any connected EFI-capable devices) is stored in the system plug. This has the advantage that it is not necessary to reconfigure the system if expansion modules or gateways are replaced.
- The Automatic Configuration Recovery (ACR) function can be used to detect and automatically reconfigure EFI-enabled devices of the same type following a replacement; see "[Automatic configuration recovery \(ACR\)](#)", page 47.
- The data saved in the system plug is retained even in the event of a power supply failure.
- Configuration information can be transmitted via the EFI interface.



NOTE

If two computers establish TCP/IP connections to the same Flexi Soft main module of a Flexi Soft Ethernet gateway in parallel (e.g., via port 9000), the Flexi Soft main module will only communicate via the most recently established connection. As a result, the second computer will establish a further connection without closing the ones already established. There comes a point when too many connections to the computers are open via the gateway and the only messages being exchanged on those computers are messages for maintaining these connections (known as keep-alive messages). This causes the Flexi Soft system to switch to the "Serious error" state.

Configuring connected devices

The configuration and verification of devices connected to the safety controller is generally not done via the configuration software of the safety controller. These devices have their own configuration and verification mechanisms.

For more information, see the operating instructions for the corresponding device.

Configuration of EFI-enabled devices



NOTE

The connection of EFI-capable devices is only possible if the Flexi Soft Designer configuration software is used. The Safety Designer configuration software does not support the EFI function.

Devices connected to the Flexi Soft main module via EFI can be configured both locally on the corresponding device and via the Flexi Soft system.

The following options are available:

- Via the RS-232 interface of the Flexi Soft main module
- Via the USB interface of the Flexi Soft main module (FX3-CPU3 and higher)
- Via Ethernet (Flexi-Soft-EtherNet/IP™-Gateway required, e.g. FX0-GENT)

The SICK CDS configuration and diagnostic software is required for the configuration and verification of the EFI-capable devices.

The “Flexi Soft in Flexi Soft Designer Configuration Software” operating instructions as well as the operating instructions of the respective device contains additional information on the use of EFI-capable devices.

7 Commissioning

7.1 Final acceptance of the application

Prerequisites

- Before commissioning, make sure that there are no persons in the hazardous area.
- Secure the hazardous area to prevent entry (e.g. by setting up warning signs, attaching barriers, and so on).
- Only appropriately trained personnel are allowed to carry out final acceptance.
- Observe the relevant laws and local regulations.

Procedure

- ▶ Check that all the safety-related parts of the system (wiring, connected sensors and control devices, configuration) conform to the relevant safety standards (e.g., IEC 62061 or ISO 13849).
- ▶ Check the devices connected to the safety controller according to the test notes in the associated operating instructions.
- ▶ Clearly mark all connecting cables and plug connectors on the safety controller to avoid mix-ups.
- ▶ Check the signal paths and make sure that they have been correctly integrated into the higher-level controller.
- ▶ Check that data is transmitted correctly to and from the safety controller.
- ▶ Check the logic program of the safety controller.
- ▶ Perform a complete validation of the safety function (e.g. error simulation). Note the response times.
- ▶ Fully document the configuration for the system and individual devices, plus the results of the safety inspection.
- ▶ To make it more difficult to overwrite the configuration unintentionally, activate the configuration write protection.

7.2 Checks before initial commissioning

Overview

Before commissioning the machine, you must check whether the safety functions are fulfilling their planned purpose and whether persons are being adequately protected.

Prerequisites

- Before initial commissioning, ensure that the system/machine is inspected by qualified safety personnel, documented, and approved.
- Before commissioning, make sure that there are no persons in the hazardous area.
- Secure the hazardous area to prevent entry (e.g. by setting up warning signs, attaching barriers, and so on).

Checks before initial commissioning

Check the protective device as described below and in accordance with the applicable standards and regulations.

- ▶ Check the effectiveness of the safety function on the machine in all operating modes and functions in which the machine can be set.
- ▶ Ensure that all operators have been instructed by the qualified safety personnel of the machine user before they start working on a machine protected by an safety controller. Instruction is the responsibility of the machine user.

8 Operation

8.1 Status messages on the FX3-CPUx main module

For information on the positions of the LEDs on the FX3-CPU0 main module, see [figure 27, page 53](#).

For information on the positions of the LEDs on the FX3-CPU1 and FX3-CPU2 main modules, see [figure 29, page 55](#).

For information on the positions of the LEDs on the FX3-CPU3 main module, see [figure 30, page 56](#).

MS LED (all main modules)

Table 80: MS LED

| MS LED | Meaning | Notes |
|--------------------------|---|--|
| ○ | Supply voltage out of range | Switch on the voltage supply of the Flexi Soft system and check at the A1 and A2 terminals of the main module. |
| ● Red/ ● Green (1 Hz) | Self-test in progress or system initializing. | Please wait ... |
| ● Green (1 Hz) | System in Stop | The application can be started from within the configuration software. |
| ● Green (2 Hz) | Identify (e.g., for Flexi Link) | - |
| ● Green | System in Run | - |
| ● Red (1 Hz) | Invalid configuration | Check module type and module version of main module and expansion modules on which the MS LED ● is flashing red/green. Modify the configuration if necessary. Use the configuration software diagnostic function. |
| ● Red (2 Hz) | Serious error in the system, presumably in this module. The application was stopped. All outputs are switched off. | Switch the power supply off and then on again. If the problem still has not been remedied after multiple repetitions, replace this module. Use the configuration software diagnostic function. |
| ● Red | Serious error in the system, presumably in a different module. The application was stopped. All outputs are switched off. | Switch the power supply off and then on again. If the problem still has not been remedied after multiple repetitions, replace the module showing ● red (2 Hz). If applicable, also use the diagnostic function in the configuration software to isolate the affected module. |

CV LED (all main modules)

Table 81: CV LED

| CV LED | Meaning | Note |
|--------------------|--|--|
| ○ | Configuration in progress. | - |
| ● Yellow (2 Hz) | Saving configuration data in the system plug (non-volatile memory) | Do not disconnect from power supply until save process has been completed. |
| ● Yellow (1 Hz) | Unverified configuration | Verify the configuration with the configuration software. |
| ● Yellow | Verified configuration | - |

EFI LEDs (FX3-CPU1 main module and higher)

Table 82: EFI LEDs

| LED EFI (EFI1 or EFI2) | Meaning | Note |
|---|--|--|
| ○ | OK | – |
| ● Red | <ul style="list-style-type: none"> Waiting for integration of EFI-enabled devices or Flexi Link station following power-up ACR execution (FX3-CPU2 and higher) | – |
| ● Red (1 Hz) | Error, e.g., <ul style="list-style-type: none"> Expected EFI-enabled device or Flexi Link station not found within 3 minutes. Integration check failed Communication interrupted EFI device address conflict Flexi Link ID conflict ACR execution error, e. g., ACR integration check failed, ACR transmission error (FX3-CPU2 and higher) | Check the wiring. Integration at a later date remains possible at all times. |
| ● Red (2 Hz, EFI1 and EFI2 alternating) | Identify (e.g., for Flexi Link) | – |

LINE LED (FX3-CPU3 main module and higher)

Table 83: LINE LED

| LINE LED | Meaning |
|--------------------|--|
| ○ | Flexi Line is not configured and not in operation. |
| ● Green | Flexi Line in operation |
| ● Green (1 Hz) | Flexi Line started, waits for neighboring station or teach possible, e.g. after system restructuring |
| ● Green (2 Hz) | Teach-in required |
| ● Red/green (2 Hz) | Flexi Line configuration necessary |
| ● Red (1 Hz) | Error on the Flexi Line bus, e.g., communication interrupted |
| ● Red | Serious error, Flexi Line stopped |

8.2 Status messages for the FX3-XTIO I/O module

For information on the positions of the LEDs on the FX3-XTIO I/O module, [see figure 31, page 57](#).

Table 84: MS LED on the FX3-XTIO I/O module

| MS LED | Meaning | Notes |
|------------------------|---|--|
| ○ | Supply voltage out of range | Switch on the voltage supply of the Flexi Soft system and check at the A1 and A2 terminals of the main module. |
| ● Red/ green (1 Hz) | With firmware V1.xx.0: invalid configuration | |
| | With firmware ≥ V2.00.0: remediable external error | Check cabling of the flashing inputs and outputs. If all output LEDs are flashing, check the supply voltage of terminals A1 and A2 on this module. |
| ● Green (1 Hz) | System in Stop | The application can be started from within the configuration software. |
| ● Green | System in Run | |
| ● Red (1 Hz) | With firmware V1.xx.0: remediable external error | Check cabling of the flashing inputs and outputs. If all output LEDs are flashing, check the supply voltage of terminals A1 and A2 on this module. |
| | With firmware ≥ V2.00.0: invalid configuration | |
| ● Red (2 Hz) | Serious error in the system, presumably in this module. The application was stopped. All outputs are switched off. | Switch the power supply off and then on again. If the problem still has not been remedied after multiple repetitions, replace this module. Use the configuration software diagnostic function. |
| ● Red | Serious error in the system, presumably in a different module. The application was stopped. All outputs are switched off. | Switch the power supply off and then on again. If the problem still has not been remedied after multiple repetitions, replace the module showing ● red (2 Hz). If applicable, also use the diagnostic function in the configuration software to isolate the affected module. |

Table 85: Input and output LEDs on the FX3-XTIO I/O module

| Input LEDs (I1 ... I8) Output LEDs (Q1 ... Q4) | Meaning |
|---|--|
| ○ | Input/output is deactivated. |
| ● Green | Input/output is active. |
| ● Green (1 Hz) synchronized with the red MS LED | Input/output is deactivated and there is a remediable error. |
| ● Green (1 Hz) alternating with the red MS LED | Input/output is active and there is a remediable error. |



NOTE

The LEDs indicate the state and are updated approx. every 64 ms.

8.3 Status messages for the FX3-XTDI I/O module

For information on the positions of the LEDs on the FX3-XTDI I/O module, see figure 32, page 58.

Table 86: MS LED on the FX3-XTDI I/O module

| MS LED | Meaning | Notes |
|------------------------|---|--|
| ○ | Supply voltage out of range | Switch on the voltage supply of the Flexi Soft system and check at the A1 and A2 terminals of the main module. |
| ● Red/ green (1 Hz) | With firmware V1.xx.0: invalid configuration | |
| | With firmware ≥ V2.00.0: remediable external error | Check cabling of the flashing inputs. If all output LEDs are flashing, check the supply voltage of terminals A1 and A2 on this module. |
| ● Green (1 Hz) | System in Stop | The application can be started from within the configuration software. |
| ● Green | System in Run | |
| ● Red (1 Hz) | With firmware V1.xx.0: remediable external error | Check cabling of the flashing inputs |
| | With firmware ≥ V2.00.0: invalid configuration | |
| ● Red (2 Hz) | Serious error in the system, presumably in this module. The application was stopped. | Switch the power supply off and then on again. If the problem still has not been remedied after multiple repetitions, replace this module. Use the configuration software diagnostic function. |
| ● Red | Serious error in the system, presumably in a different module. The application was stopped. | Switch the power supply off and then on again. If the problem still has not been remedied after multiple repetitions, replace the module showing ● red (2 Hz). If applicable, also use the diagnostic function in the configuration software to isolate the affected module. |

Table 87: Input LEDs on the FX3-XTDI I/O module

| Input LEDs (I1 ... I8) | Meaning |
|---|---|
| ○ | Input is deactivated. |
| ● Green | Input is active. |
| ● Green (1 Hz) synchronized with the red MS LED | Input is deactivated and there is a remediable error. |
| ● Green (1 Hz) alternating with the red MS LED | Input is active and there is a remediable error. |

**NOTE**

The LEDs indicate the state and are updated approx. every 64 ms.

8.4 Status messages for the FX3-XTDS I/O module

For information on the positions of the LEDs on the FX3-XTDS I/O module, [see figure 33, page 59](#).

Table 88: MS LED on the FX3-XTDS I/O module

| MS LED | Meaning | Notes |
|------------------------|---|--|
| ○ | Supply voltage out of range | Switch on the voltage supply of the Flexi Soft system and check at the A1 and A2 terminals of the main module. |
| ● Red/ green (1 Hz) | Remediable external error | Check cabling of the flashing inputs and outputs. If all output LEDs are flashing, check the supply voltage of terminals A1 and A2 on this module. |
| ● Green (1 Hz) | System in Stop | The application can be started from within the configuration software. |
| ● Green | System in Run | |
| ● Red (1 Hz) | Invalid configuration | |
| ● Red (2 Hz) | Serious error in the system, presumably in this module. The application was stopped. All outputs are switched off. | Switch the power supply off and then on again. If the problem still has not been remedied after multiple repetitions, replace this module. Use the configuration software diagnostic function. |
| ● Red | Serious error in the system, presumably in a different module. The application was stopped. All outputs are switched off. | Switch the power supply off and then on again. If the problem still has not been remedied after multiple repetitions, replace the module showing ● red (2 Hz). If applicable, also use the diagnostic function in the configuration software to isolate the affected module. |

Table 89: Input and output LEDs on the FX3-XTDS I/O module

| Input LEDs (I1 ... I8) Output LEDs (XY1, XY2, and Y3 ... Y6) | Meaning |
|---|--|
| ○ | Input/output is deactivated. |
| ● Green | Input/output is active. |
| ● Green (1 Hz) synchronized with the red MS LED | Input/output is deactivated and there is a remediable error. |
| ● Green (1 Hz) alternating with the red MS LED | Input/output is active and there is a remediable error. |



NOTE

The LEDs indicate the state and are updated approx. every 64 ms.

8.5 Status messages for the FX0-STIO I/O module

For information on the positions of the LEDs on the FX0-STIO I/O module, see [figure 34, page 60](#).

Table 90: MS LED on the FX0-STIO I/O module

| MS LED | Meaning | Notes |
|------------------------|---|--|
| ○ | Supply voltage out of range | Switch on the voltage supply of the Flexi Soft system and check at the A1 and A2 terminals of the main module. |
| ● Red/ green (1 Hz) | Remediable external error | Check cabling of the flashing inputs and outputs. If all output LEDs are flashing, check the supply voltage of terminals A1 and A2 on this module. |
| ● Green (1 Hz) | System in Stop | The application can be started from within the configuration software. |
| ● Green | System in Run | |
| ● Red (1 Hz) | Invalid configuration | |
| ● Red (2 Hz) | Serious error in the system, presumably in this module. The application was stopped. All outputs are switched off. | Switch the power supply off and then on again. If the problem still has not been remedied after multiple repetitions, replace this module. Use the configuration software diagnostic function. |
| ● Red | Serious error in the system, presumably in a different module. The application was stopped. All outputs are switched off. | Switch the power supply off and then on again. If the problem still has not been remedied after multiple repetitions, replace the module showing ● red (2 Hz). If applicable, also use the diagnostic function in the configuration software to isolate the affected module. |

Table 91: Input/output LEDs on the FX0-STIO I/O module

| Input LEDs (I1 ... I6) Output LEDs (Y1 ... Y6) Input/output LEDs (IY7, IY8) | Meaning |
|---|--|
| ○ | Input/output is deactivated. |
| ● Green | Input/output is active. |
| ● Green (1 Hz) synchronized with the red MS LED | Input/output is deactivated and there is a remediable error. |
| ● Green (1 Hz) alternating with the red MS LED | Input/output is active and there is a remediable error. |

**NOTE**

The LEDs indicate the state and are updated approx. every 64 ms.

8.6 Status signals of the FX3-ANA0 analog input module

For information on the positions of the LEDs on the FX3-ANA0, [see figure 43, page 75](#).

Table 92: Statuses indicated by the MS LED on the FX3-ANA0 analog input module

| MS LED | Meaning | Notes |
|--------------------|---|--|
| ○ | Supply voltage out of range | Switch on the voltage supply of the Flexi Soft system and check at the A1 and A2 terminals of the main module. |
| ◐ Red/green (1 Hz) | Remediable external error | Check cabling of the flashing inputs |
| ◑ Green (1 Hz) | System in Stop status | The application can be started using the configuration software. |
| ● Green | System in Run status | |
| ◐ Red (1 Hz) | Invalid configuration | |
| ◑ Red (2 Hz) | Serious error in the system, probably in this module. The application was stopped. All outputs are switched off. | Switch the voltage supply off and then on again. If the problem still has not been remedied after multiple repetitions, replace this module. Use the configuration software diagnostic function. |
| ● Red | Serious error in the system, probably in a different module. The application was stopped. All outputs are switched off. | Switch the voltage supply off and then on again. If the problem still has not been remedied after multiple repetitions, replace the module showing ◑ red (2 Hz). If applicable, also use the diagnostic function in the configuration software to isolate the affected module. |

Table 93: Statuses indicated by the input LEDs on the FX3-ANA0 analog input module

| Input LEDs AI1, AI2 | Meaning |
|--|---|
| ○ | Input is deactivated. |
| ● Green | Input is active. |
| ◐ Green (1 Hz) synchronized with the ◐ red/green MS LED (1 Hz) | Input is deactivated and there is a remediable error. |

8.7 Status messages of the FX3-MOCx motion control module

For information on the position of the LEDs on the FX3-MOCx motion control module, see [figure 35, page 60](#).

Table 94: Displays of the MS LED on the FX3-MOCx motion control module

| MS LED | Meaning | Notes |
|------------------------|---|--|
| ○ | Supply voltage out of range | Switch on the voltage supply of the Flexi Soft system and check at the A1 and A2 terminals of the main module. |
| ◐ Red/ green (1 Hz) | Remediable external error | Check the encoder signals. Use the configuration software diagnostic function. |
| ◑ Green (1 Hz) | System in Stop | The application can be started from within the configuration software. |
| ● Green | System in Run | |
| ◐ Red (1 Hz) | Invalid configuration | |
| ◑ Red (2 Hz) | Serious error in the system, presumably in this module. The application was stopped. All outputs are switched off. | Switch the power supply off and then on again. If the problem still has not been remedied after multiple repetitions, replace this module. Use the configuration software diagnostic function. |
| ● Red | Serious error in the system, presumably in a different module. The application was stopped. All outputs are switched off. | Switch the power supply off and then on again. If the problem still has not been remedied after multiple repetitions, replace the module showing ◑ red (2 Hz). If applicable, also use the diagnostic function in the configuration software to isolate the affected module. |

8.8 Status messages of the UE410-2RO and UE410-4RO relay modules

For information on the positions of the LEDs on the UE410-2RO and UE410-4RO relay modules, see [figure 44, page 76](#) and see [figure 45, page 76](#).

Table 95: Statuses indicated by the LEDs on the UE410-2RO and UE410-4RO relay modules

| LED display | Meaning |
|--------------|--|
| PWR (green) | Supply voltage via safety bus on. |
| K1/2 (green) | Relay K1/K2 – safety contacts closed |
| K3/4 (green) | Relay K1/K2 – safety contacts closed (on the UE410-4RO only) |

9 Maintenance

9.1 Regular thorough check of the safety function by qualified safety personnel

- ▶ Check the system following the inspection intervals specified in the national rules and regulations. This procedure ensures that any changes to the machine or tampering with the protective device are detected after initial commissioning.
- ▶ Every safety application must be checked at fixed intervals you define. The effectiveness of the safety function must be checked by qualified and authorized personnel.
- ▶ If alterations have been made to the machine or safety function, or if the safety controller has been changed or repaired, for example by exchanging a module, check the plant again using the checklist in the appendix.
- ▶ Carry out regular inspections in order to keep the Flexi Soft modules in perfect working order.
- ▶ Check that the implementation of the Flexi Soft modules complies with all technical data.
- ▶ Check the mounting conditions and check that the Flexi Soft module wiring is correct.
- ▶ To ensure their reliability, check at regular intervals that the safety functions are meeting the requirements of the application as well as all applicable regulations and standards (e.g., regular thorough check).

9.2 Device replacement

Overview

A serious error in one of the Flexi Soft modules impairs the entire network. Therefore devices that indicate serious errors must be quickly repaired or exchanged. It is recommended to keep replacement devices for the Flexi Soft modules ready in order to restore operation as quickly as possible.

Important information



WARNING

Ineffectiveness of the protective device due to device replacement

The dangerous state may not be stopped or not be stopped in a timely manner in the event of non-compliance.

- ▶ After exchanging the device, ensure that no errors occur with the new Flexi Soft modules.
 - ▶ Always carry out a function test before commissioning a replacement module.
 - ▶ After exchanging an FX3-MOC1, carry out reference and/or teach-in process once again if the Position by Reference with Memory Function function block or SSI encoder with teach-in input is used.
-

**NOTE**

- EFI-capable devices do not need to be reconfigured after exchanging a Flexi Soft module.
- If a Flexi Soft module needs to be sent in for repair, then first a report of the project including the diagnostics messages of the Flexi Soft system has to be generated using the configuration software. Send the Flexi Soft module in question together with this report, a detailed description of the problem and all other available information to SICK.
- If you send in an FX3-MPLO or FX3-MPL1 system plug for repair or analysis, it will be returned in the state of delivery, i.e. with an empty configuration. Save your configuration as a project file using the configuration software is therefore recommended.

Prerequisites

- Do not disassemble or repair Flexi-Soft modules.
- Only replace the device when the voltage supply is switched off

Procedure

- ▶ Dismantle the defective module.
- ▶ Mount the new module.
- ▶ Restore the device to a safe state.
- ▶ To be able to use the system configuration again, check the following points:
 - Is the new module of the same type (same part number) and are there no errors on the new module after exchange?
 - Has the new module been placed in the same position that the removed module was in?
 - Have all plug connectors been reconnected in the right location?
- ▶ Otherwise the new system will have to be completely reconfigured and commissioned, including all necessary thorough checks.

Further topics

- ["Mounting procedure", page 49](#)
- ["Removal", page 130](#)

10 Troubleshooting

10.1 Response to errors



WARNING

Malfunction of the protective device

The dangerous state may not be stopped or not be stopped in a timely manner in the event of non-compliance.

- ▶ Immediately put the plant/machine out of operation if it is not possible to clearly allocate the fault and safely remedy it.
- ▶ After remedying a fault, carry out an effects analysis and check all affected safety functions.

10.2 Error states

If certain malfunctions or a fault configuration occurs, the Flexi Soft safety controller goes into a safe state. The LEDs of the individual modules of the safety controller show the respective error state.

The error state will vary depending on the nature of the error:

Configuration error

- The system is in the Configuration required state (MS LED red (1 Hz)).
- The applications in all modules are in the Stop state.
- All safety outputs of the system are switched off.
- All safe process data is set to zero. The non-safety-related process data is typically also set to zero.

Remediable error

- The applications in all modules remain in the Run state (MS LED on the affected modules = alternate red/green (1 Hz), MS LED on modules that are not affected = green).
- If safety outputs of the system are affected, then at least these are switched off.
- If safety inputs are affected, then at least the process data of these safety inputs are set to zero.

Serious error

- The system is in the Serious error state (MS LED on the module that has detected the serious error = red (2 Hz). MS LED on the modules on which the cause of the error is unknown = red).
- The applications in all modules are in the Stop state.
- All safety outputs of the system are switched off.
- All safe process data is set to zero. The non-safety-related process data is typically also set to zero.

Recommissioning

- ▶ Remedy the cause of the error based on the MS, CV, and EFI LED displays.
- ▶ In the event of serious errors, switch the power supply to the Flexi Soft system off for at least 3 seconds and then switch it back on again.

10.3 Error displays shown by status LEDs, error messages, and troubleshooting measures





The most important error codes, possible causes, and possible troubleshooting measures are listed in this chapter. These error messages can be displayed with the diagnostics function of the configuration software if you have established a connection to the Flexi Soft system.



















NOTE

- For information about how to perform diagnostics, please refer to the “Flexi Soft in the Flexi Soft Designer Configuration Software” or “Flexi Soft in the Safety Designer Configuration Software” operating instructions.
 - Error displays and troubleshooting for the individual modules are described in the sections on the corresponding modules (see ["Status messages on the FX3-CPUx main module"](#), page 108 to see ["Status messages of the UE410-2RO and UE410-4RO relay modules"](#), page 115).
-

Table 96: Error codes and error messages in the Flexi Soft system and possible troubleshooting measures

| LED display on the module | | Possible error codes | Possible causes | Possible measures |
|---|--|---|---|---|
| Main module FX3-CPUx | Expansion module ¹⁾ | | | |
| MS =  red (1 Hz) | All expansion modules: MS =  red (1 Hz) (firmware ≥ V2.00.0) or MS =  red/  green (1 Hz) (firmware V1.xx.0) | Main module: 0x000E4006, 0x00160005, 0x000F0013 | The configuration in the system plug is incompatible, because it is intended for a different type of main module: <ul style="list-style-type: none"> • The system plug has been previously used in a system with a different type of main module (e.g., FX3-CPU0 instead of FX3-CPU1, or vice versa). • An incorrect main module has been used in the hardware installation. | <ul style="list-style-type: none"> • Transfer a configuration with the same type of main module as in the hardware installation. • Replace the main module in the hardware installation with a main module of the same type as in the project file. |
| | | Main module: 0x00170005, 0x000F0013 | The configuration in the system plug is incompatible, because it is intended for more recent firmware version of the main module: <ul style="list-style-type: none"> • The system plug has been configured for an incompatible more recent firmware version of the main module (e.g., V2.00.0 instead of V1.11.0). • An older firmware version of the main module has been used in the hardware installation. | <ul style="list-style-type: none"> • Transfer a configuration with the same or an older firmware version (e.g, V1.xx.0 instead of V2.xx.0). • Replace the main module in the hardware installation with a module with a more recent or identical firmware version as in the project file. |
| | | Main module: 0x000E4013, 0x00274006 | The configuration in the system plug is incompatible with at least one expansion module: <ul style="list-style-type: none"> • An expansion module is missing in the hardware installation. | <ul style="list-style-type: none"> • Transfer a configuration with a suitable number of expansion modules. • Add the missing expansion module to the hardware installation. |
| | | Main module: 0x000E0006, 0x0005000D FX3-XTIO/-XTDI: 0x4901, 0x4904 | The configuration in the system plug is invalid: <ul style="list-style-type: none"> • The last configuration operation was not completed successfully, e.g., because the power supply was switched off before the write operation to the system plug was completed. • Hardware error in system plug • The system plug is empty (condition on delivery). | <ul style="list-style-type: none"> • Transfer the configuration again and make sure that the power supply at the main module remains switched on until the transfer operation is complete. • Replace the system plug and transfer the configuration again. |

| LED display on the module | | Possible error codes | Possible causes | Possible measures |
|---|--|---|---|--|
| Main module FX3-CPUx | Expansion module ¹⁾ | | | |
| MS =  red (1 Hz) EFI =  red (1 Hz) | One or more expansion modules: MS =  red (1 Hz) (firmware ≥ V2.00.0) or MS =  red/green (1 Hz) (firmware V1.xx.0) | Main module: 0x0014000A | If FX3-CPU1: EFI device address conflict: <ul style="list-style-type: none"> At least 2 main modules with the same EFI address are connected. | <ul style="list-style-type: none"> Change the EFI address of the main module or the connected device in the configuration software. |
| | | Main module: 0x0015000A | If FX3-CPU1 and Flexi Link: incorrect Flexi Link ID: <ul style="list-style-type: none"> EFI1 and EFI2 were mixed up during wiring. At least 1 main module with an incorrect Flexi Link ID is connected. | <ul style="list-style-type: none"> Check the wiring between the Flexi Link stations: EFI1 must be connected to EFI1 and, if applicable, EFI2 to EFI2. Connect Flexi Link stations with correct IDs. Transfer the configuration to all Flexi Link stations with the same Flexi Link IDs. |
| | | Main module: 0x001F0006, 0x00230006, 0x00234006, 0x001F4006 | The configuration in the system plug is incompatible with at least one expansion module: <ul style="list-style-type: none"> Incorrect module type or incorrect module version (MS LED on module is flashing red or red/green). Too many expansion modules are connected. (MS LED on module is flashing red or red/green.) Expansion modules are missing. (MS LEDs on all other modules are flashing red or red/green.) | <ul style="list-style-type: none"> Transfer a configuration with the same module type and the same or an older firmware version of all expansion modules. Replace the expansion module affected in the hardware installation with a module of the same type and a firmware version that is older than or identical to the one in the project file. |
| MS =  green (1 Hz) CV =  yellow (1 Hz) | MS =  green (1 Hz) | - | The system is in the Stop state (ready for operation). | The application can be started from within the configuration software. For automatic starting following power-up, the project must be verified with the configuration software. |
| MS =  green (1 Hz) CV =  yellow | MS =  green (1 Hz) | - | The system is in the Stop state (ready for operation). | The application can be started from within the configuration software. |
| MS =  green | MS =  green | - | The system is in operation. No errors detected. | - |
| MS =  green | One or more expansion modules: MS =  red/green (1 Hz) (firmware ≥ V2.00.0) or MS =  red (1 Hz) (firmware V1.xx.0) and Q1 + Q2 + Q3 + Q4 =  green (1 Hz) | FX3-XTIO: 0x4804, 0x4806, 0x4807 | The supply voltage of an FX3-XTIO module is too low or is missing. | Check the power supply at terminals A1 (24 V) and A2 (GND) on the FX3-XTIO module, including under worst-case conditions. The error is reset automatically after approx. 8 seconds if its cause is no longer present. |

| LED display on the module | | Possible error codes | Possible causes | Possible measures |
|---------------------------|---|--|---|---|
| Main module FX3-CPUx | Expansion module ¹⁾ | | | |
| MS = ● green | One or more expansion modules: MS = ● red/green (1 Hz) (firmware ≥ V2.00.0) or MS = ● red (1 Hz) (firmware V1.xx.0) and Q1 or Q2 or Q3 or Q4 = ● green (1 Hz) | FX3-XTIO: 0x4701, 0x4702, 0x4704, 0x4705 | <ul style="list-style-type: none"> • Short-circuit to 24 V or cross-circuit in the wiring of safety output Q1 to Q4 (whose LED flashes) • Capacitive load exceeds permissible maximum value (e.g., due to spark quenching capacitor). • Inductive load exceeds permissible maximum value. • Internal hardware in FX3-XTIO module • Short-circuit to GND in the wiring of safety output Q1 to Q4 (whose LED flashes) • Power supply at FX3-XTIO module interrupted briefly | <ul style="list-style-type: none"> • Check the wiring of the affected output. • Check the capacitive load. • Check the inductive load. • Replace the FX3-XTIO module. <p>To reset the error, all outputs of the affected module must be switched off by the logic of the main module by switching off the associated input signals (e.g., emergency stop). It can take up to 8 seconds to reset the error. Alternatively, reset the voltage at the main module.</p> |
| MS = ● green | One or more expansion modules: MS = ● red/green (1 Hz) (firmware ≥ V2.00.0) or MS = ● red (1 Hz) (firmware V1.xx.0) and I1 or I2 or I3 or I4 or I5 or I6 or I7 or I8 = ● green (1 Hz) | FX3-XTIO/-XTDI: 0x4601 | <p>Inputs connected to a test output:</p> <ul style="list-style-type: none"> • Short-circuit to 24 V or cross-circuit in the wiring of tested sensors: <ul style="list-style-type: none"> ○ a) Short-circuit to 24 V or cross-circuit in the wiring of X1, X2, ... or X8 to a tactile switch or to a test input of a testable input ○ b) Short-circuit to 24 V or cross-circuit in the wiring of a tactile switch or an output of a testable sensor to I1, I2, ... or I8 • Defective testable sensor • Cable break in the wiring of a pressure-sensitive safety mat: <ul style="list-style-type: none"> ○ a) Cable break in the wiring of X1, X2, ... or X8 to the pressure-sensitive safety mat ○ b) Cable break in the wiring from the pressure-sensitive safety mat to I1, I2, ... or I8 • Defective pressure-sensitive safety mat | <ul style="list-style-type: none"> • Check the wiring of the affected input. • Replace the testable sensor. <p>To reset the error, switch off the affected input (input state Low/Low for equivalent dual-channel inputs, Low/High for complementary dual-channel inputs) or reset the voltage at the main module.</p> |

| LED display on the module | | Possible error codes | Possible causes | Possible measures |
|--|---|--|---|---|
| Main module FX3-CPUx | Expansion module ¹⁾ | | | |
| MS = ● green | One or more expansion modules: MS = ● red/green (1 Hz) (firmware ≥ V2.00.0) or MS = ● red (1 Hz) (firmware V1.xx.0) and I1 + I2 or I3 + I4 or I5 + I6 or I7 + I8 = ● green (1 Hz) | FX3-XTIO/-XTDI: 0x4429 or 0x442A | Discrepancy error or sequence error at dual-channel inputs (associated LEDs flashing green): <ul style="list-style-type: none"> Cable break or short-circuit to GND at one of the two input signals of the input pair Sensor hardware error (e.g., is one of the two contacts/outputs permanently closed (High) or open (Low)). Defective sensor (one of the two signals is not switching to a state corresponding to the other input within the configured discrepancy time). The safety door opened or closed too slowly; as a result, both contact switches (e.g., reed contacts) did not switch within the configured discrepancy time. Only one of the two inputs triggered the switch-off condition and then switched back to the ON state, while the value of the other input did not change at all (sequence error). | <ul style="list-style-type: none"> Check the wiring of the affected input and check the switching capacity of the two contacts/outputs of the connected sensor. Check the mechanical dependence of the two switches. Replace the switch/sensor in the hardware installation. <p>To reset the error, the affected input pair must be Low/Low in the case of equivalent dual-channel inputs and Low/High in the case of complementary dual-channel inputs.</p> |
| MS = ● red | MS = ● red | Main module: 0xFFFF Expansion modules: 0xCXXX (X = random value) | <ul style="list-style-type: none"> Power supply GND at the FX3-XTIO module is missing (only with firmware V1.xx.0). Internal error in the expansion module Internal error in the main module | <ul style="list-style-type: none"> Check the connection from terminal A2 on the FX3-XTIO modules to the power supply GND. Check the system for electromagnetic interference (grounding of the DIN mounting rail, etc.). To reset the error, reset the voltage at the main module. If the error persists, replace the modules. |
| MS = ● red | MS = ● red (2 Hz) (firmware ≥ V2.00.0) | Main module: 0xFFFF Expansion modules: 0xCXXX (X = random value) | Internal error in the expansion module (associated MS LED flashing) | <ul style="list-style-type: none"> Check the system for electromagnetic interference (grounding of the DIN mounting rail, etc.). To reset the error, reset the voltage at the main module. If the error persists, replace the module on which the MS LED is flashing. |
| MS = ● red (2 Hz) (firmware ≥ V2.00.0) | MS = ● red | Main module: 0xFFFF Expansion modules: 0xCXXX (X = random value) | Internal error in the main module or in the system | <ul style="list-style-type: none"> Check the system for electromagnetic interference (grounding of the DIN mounting rail, etc.). To reset the error, reset the voltage at the main module. If the error persists, replace the main module followed by the expansion modules. |

| LED display on the module | | Possible error codes | Possible causes | Possible measures |
|-------------------------------|--------------------------------|--|---|---|
| Main module FX3-CPUx | Expansion module ¹⁾ | | | |
| MS = ● red or ● red (2 Hz) | MS = ● red or ● red (2 Hz) | Main module: 0x0006C002, 0x0007C002, 0x0001C005, 0x0003C006, 0x0005C006, 0x0029C006, 0x0003C013 | <ul style="list-style-type: none"> Consequential error further to another serious error Fault affecting the internal signals of the main module caused by significant electromagnetic interference Hardware error in the main module or in an expansion module | <ul style="list-style-type: none"> Check the other diagnostic messages for serious errors with a very similar time stamp. To reset the error, reset the voltage at the main module. If the error persists, replace the main module followed by the expansion modules. |
| | | Main module: 0x0001C013, 0x0004C013, 0x0005C013, 0x000CC013 | <ul style="list-style-type: none"> FLEXBUS+ communication (backplane bus communication with I/O modules and gateways) faulty due to electromagnetic interference FLEXBUS+ communication (backplane bus communication with I/O modules and gateways) faulty due to a serious error in I/O modules. This is a consequential error and there are other messages relating to serious errors with a very similar time stamp (± 1 s) in the diagnostic history. | <ul style="list-style-type: none"> To reset the error, reset the voltage at the main module. Check the system with regard to electromagnetic interference (FE connection for DIN mounting rail and control cabinet, star wiring of the 24 V power supply, local isolation of load and control elements, etc.). Check the other diagnostic messages with a very similar time stamp. |
| | | Main module: 0x002AC006 | Incompatible input data from the expansion module: <ul style="list-style-type: none"> A dual-channel input at an FX3-XTIO or FX3-XTDI module has two signal dips (High to Low) in a time distance of 2 ms (e.g. test pulse widths of an OSSD output or bouncing relay contacts). A signal input at an FX3-XTIO or FX3-XTDI module changes its state in 4 ms intervals during a period of 40 ms or more (e.g., proximity switch at a gear wheel). With on-off filter times > 500 ms at a signal input of the FX3-XTIO, an error may occur. | <ul style="list-style-type: none"> To reset the error, reset the voltage at the main module. Change the configuration by activating the on-off filter and the on-off filter for the inputs of the FX3-XTIO or FX3-XTDI module concerned. Please note that this extends the response time for this signal by at least 8 ms. If possible, use filter times ≤ 500 ms. |

| LED display on the module | | Possible error codes | Possible causes | Possible measures |
|--|--|---|--|--|
| Main module FX3-CPUx | Expansion module ¹⁾ | | | |
| MS = ● red or ● red (2 Hz) (continued) | MS = ● red or ● red (2 Hz) (continued) | FX3-XTIO/-XTDI: 0xC306 Main module: 0x0029C006 | <ul style="list-style-type: none"> Internal hardware in FX3-XTIO or FX3-XTDI module Consequential error on main module: 0x0029C006 | <ul style="list-style-type: none"> To reset the error, reset the voltage at the main module. Replace the FX3-XTIO or FX3-XTDI module in the hardware installation. |
| | | FX3-XTIO/-XTDI: 0xC307 Main module: 0x0029C006 | <ul style="list-style-type: none"> Power supply at terminal A2 (GND) of the FX3-XTIO module interrupted Internal hardware in FX3-XTIO or FX3-XTDI module Consequential error on main module: 0x0029C006 | <ul style="list-style-type: none"> Check the supply voltage at terminals A1 (24 V) and A2 (GND) on the FX3-XTIO module, including under worst-case conditions. To reset the error, reset the voltage at the main module. If the error persists, replace the FX3-XTIO or FX3-XTDI module in the hardware installation. |
| | | FX3-XTIO/-XTDI: 0xC30A Main module: 0x0029C006 | <ul style="list-style-type: none"> Short-circuit to 24 V or cross-circuit in the wiring of safety output Q1 to Q4 (whose LED flashes) Capacitive load exceeds permissible maximum value (e.g., due to spark quenching capacitor). Inductive load exceeds permissible maximum value. Internal hardware in FX3-XTIO module Consequential error on main module: 0x0029C006 | <ul style="list-style-type: none"> Check the wiring of the affected output. Check the capacitive load. Check the inductive load. To reset the error, reset the voltage at the main module. If the error persists, replace the FX3-XTIO module in the hardware installation. |

| LED display on the module | | Possible error codes | Possible causes | Possible measures |
|---------------------------|--|-------------------------|--|---|
| Main module FX3-CPUx | Expansion module ¹⁾ | | | |
| MS = ● green | All expansion modules: MS = ● green | Main module: 0x000A0011 | <ul style="list-style-type: none"> Function block error during dual-channel input evaluation (e.g., emergency stop, solenoid switch): discrepancy error at input pair 1 of the function block Cable break or short-circuit to GND at one of the two input signals of the input pair Sensor hardware error (e.g., is one of the two contacts/outputs permanently closed (High) or open (Low)). Defective sensor (one of the two signals is not switching to a state corresponding to the other input within the configured discrepancy time). The safety door opened or closed too slowly; as a result, both contact switches (e.g., reed contacts) did not switch within the configured discrepancy time. | <ul style="list-style-type: none"> Check the wiring of the affected input and check the switching capacity of the two contacts/outputs of the connected sensor. Check the mechanical dependence of the two switches. Replace the switch/sensor in the hardware installation. <p>To reset the error, the affected input pair must switch from Low/Low to High/High in the case of equivalent dual-channel inputs and from Low/High to High/Low in the case of complementary dual-channel inputs within the configured discrepancy time.</p> |
| | | Main module 0x00100011 | <ul style="list-style-type: none"> Function block error (external device monitoring or valve monitoring): The feedback signal was not sent in response to the control signal within the maximum feedback delay time. Hardware error affecting the connected relay/valve or error in the wiring The relay/valve used has a longer switching delay at the monitoring contact. | <ul style="list-style-type: none"> Increase the maximum feedback delay time for the function block if this is compatible with your application. Replace the relay/valve in the hardware installation. |

| LED display on the module | | Possible error codes | Possible causes | Possible measures |
|--|--|-------------------------|---|--|
| Main module FX3-CPUx | Expansion module ¹⁾ | | | |
| All LEDs briefly off, then LED test sequence | All LEDs briefly off, then LED test sequence | Main module: 0x002D4006 | <ul style="list-style-type: none"> The power supply to the main module was affected by a brief voltage dip (almost to 0 V). The voltage of the voltage supply to the main module dropped (to between approx. 6 V and 16 V) and then rose back into the operating range. | <ul style="list-style-type: none"> Ensure that the power supply unit is able to jumper an interruption in the power supply lasting up to 20 ms. Ensure that the power supply unit is able to operate the load so that load switching cannot cause the voltage to drop. Check the wiring of the power supply to the main module. Use separate cables to other heavy loads in order to avoid a voltage dip on the supply cable caused by other load currents. |
| | | Main module: 0x003E4006 | <p>The system has performed a restart due to faults occurring on the FLEXBUS+:</p> <ul style="list-style-type: none"> FLEXBUS+ communication (backplane bus communication with I/O modules and gateways) faulty due to electromagnetic interference FLEXBUS+ communication (backplane bus communication with I/O modules and gateways) faulty due to a serious error in an expansion module (I/O module or gateway). This is a consequential error and there are other messages relating to serious errors with a very similar time stamp (± 1 s) in the diagnostic history. | <ul style="list-style-type: none"> Check the system with regard to electromagnetic interference (FE connection for DIN mounting rail and control cabinet, star wiring of the power supply (24 V and GND), local isolation of load and control elements, etc.). Check the other diagnostic messages with a very similar time stamp. |

¹⁾ FX3-XTIO, FX3-XTDI, FX3-XTDS, FX0-STIO, FX3-ANA0, and FX3-MOCx.

10.4 Error history

The diagnostic function of the configuration software allows you to read out the fault history from the Flexi Soft system and to print or store this in the report as a PDF file. For detailed information, see the “Flexi Soft in the Flexi Soft Designer Configuration Software” and “Flexi Soft in the Safety Designer Configuration Software” operating instructions.

10.5 Measures against common causes of error

Overview

The following notes are identical for all FX3-MOCx modules.

Measures against common causes of error

In particular when both encoders are used for redundant monitoring of an axis, the following possibilities must be taken into account, among others:

- The common GND connection can be interrupted by the common connecting cable on the FX3-MOCx for both encoders as a common reference potential for both encoders.
- The supply voltage for the encoder can be too low or completely interrupted.
- The common supply voltage for both encoders can be too high. This may damage both encoders. When using PELV/SELV voltage supplies without additional protective measures, you must usually assume a voltage increase to 60 V here.
- The entire encoder connection to the FX3-MOCx can be interrupted.

The following options are available to detect errors in the encoder system with the Flexi Soft safety controller:

- Use at least one encoder/motor feedback connection box. A description of this function can be found in the “Flexi Soft in the Flexi Soft Designer Configuration Software” and “Flexi Soft in the Safety Designer Configuration Software” operating instructions in the “Encoder connection type and monitoring of ID identifier” section.
- Use a sine/cosine encoder with activated sine/cosine analog voltage monitoring.
7) A description of this function can be found in the “Flexi Soft in the Flexi Soft Designer Configuration Software” and “Flexi Soft in the Safety Designer Configuration Software” operating instructions in the “Sine-cosine analog voltage monitoring” section.
- Use an SSI encoder with evaluation of error bits. A bit in the SSI data is needed which takes on an inverted state if the observed error occurs, for example because the supply voltage of the encoders is too low or because one or several of the cables from the encoder to the FX3-MOCx are disconnected. A description of this function can be found in the “Flexi Soft in the Flexi Soft Designer Configuration Software” and “Flexi Soft in the Safety Designer Configuration Software” operating instructions in the “SSI encoder” section.
- There is no possibility to detect faults immediately using the encoder signals when using A/B incremental encoders.⁸⁾
- Additionally, in certain cases there will be the option to check the plausibility of the encoder’s motion signal using another signal from the process in conjunction with the logic of the motion control module and main module, e.g. with a signal "drive running/not running".
- Use separate voltage supplies for both encoders.

There are the following options to control the voltage increase within the limits of a PELV/SELV voltage supply, as long as the faults to be accepted are not controlled by one of the selected monitoring functions:

- ▶ Use separate voltage supplies for both encoders.
- ▶ Use encoders that are equipped for the increased supply voltage to be accepted.
- ▶ Either use the voltage supply of the FX3-MOCx module for the encoder (ENC1_24V and/or ENC2_24V) directly or via the encoder/motor feedback connection unit. If the supply voltage for the Flexi Soft system exceeds 35 V at the system plug of the main module, then the system switches into a safe state, i.e. the safety outputs are switched off. In this way, safe switching off in the application in the event of a voltage increase can be controlled. In this case, it is still possible for the encoder to be damaged.

7) Configurable for sine/cosine encoders in the hardware configuration of the configuration software.

8) This also applies for A/B incremental encoders with 2 output pairs. Fault detection based on the inverted output signals would allow for cable monitoring, although it would not be possible to detect all faults to be accepted in an A/B incremental encoder such as a static state of the output level.

10.6 SICK support

If you cannot remedy an error with the help of the information in the relevant Flexi Soft operating instructions, please contact your SICK subsidiary.

11 Decommissioning

11.1 Removal

Procedure

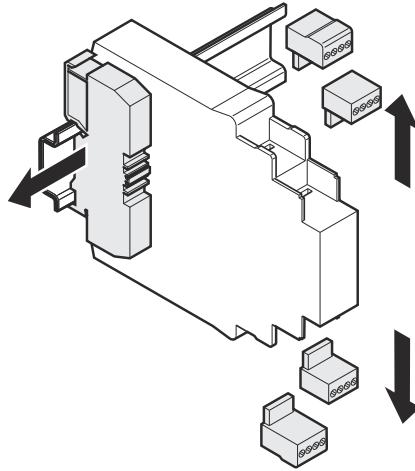

Figure 62: Detaching the plug-in terminals

1. Remove the plug-in terminals along with the wiring and the end pieces.

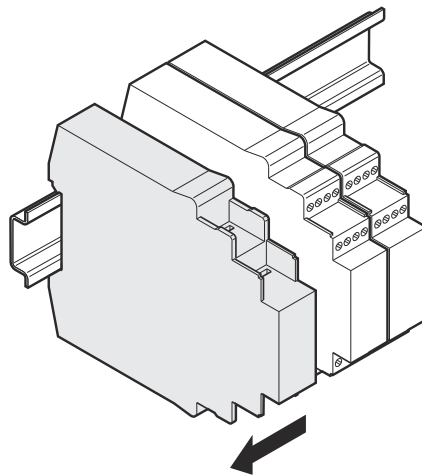

Figure 63: Disconnecting the plug connections

2. Slide the modules apart one by one in the direction of the arrow until the side-mounted plug connection is disconnected.

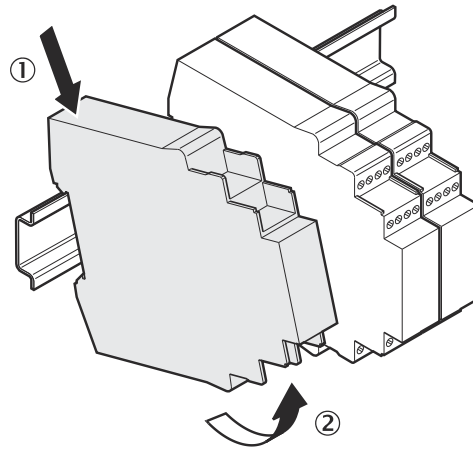

Figure 64: Removing the modules from the DIN mounting rail

3. Push the module down at the back (①). With the module still pushed down, move it in the direction of the arrow to remove it from the DIN mounting rail (②).

11.2 Disposal

Procedure

- ▶ Always dispose of unusable devices in accordance with national waste disposal regulations.



Complementary information

SICK will be glad to help you dispose of these devices on request.

12 Technical data

12.1 Minimum switch-off time

The minimum switch-off time (e.g. of the connected sensors) is the minimum time during which a switch-off condition must be present to be recognized by the Flexi Soft system.

The minimum switch-off time must correspond to the following requirements:

- It must be greater than the logic execution time + 1 ms.
And:
- When connected to the device via a Flexi Soft test output, it must be greater than the test gap + the maximum OFF-ON delay, when the test gap is > 1 ms.
And:
- It must be greater than the test period (i.e. the higher value of the two test outputs used) + the maximum OFF-ON delay if safety mats or bumpers are used. ⁹⁾

The minimum switch-off time of the sensors is usually listed in the technical data for the sensors.

12.2 Maximum response time of the Flexi Soft system

All paths must be taken into account when calculating the response times in a Flexi Soft system.

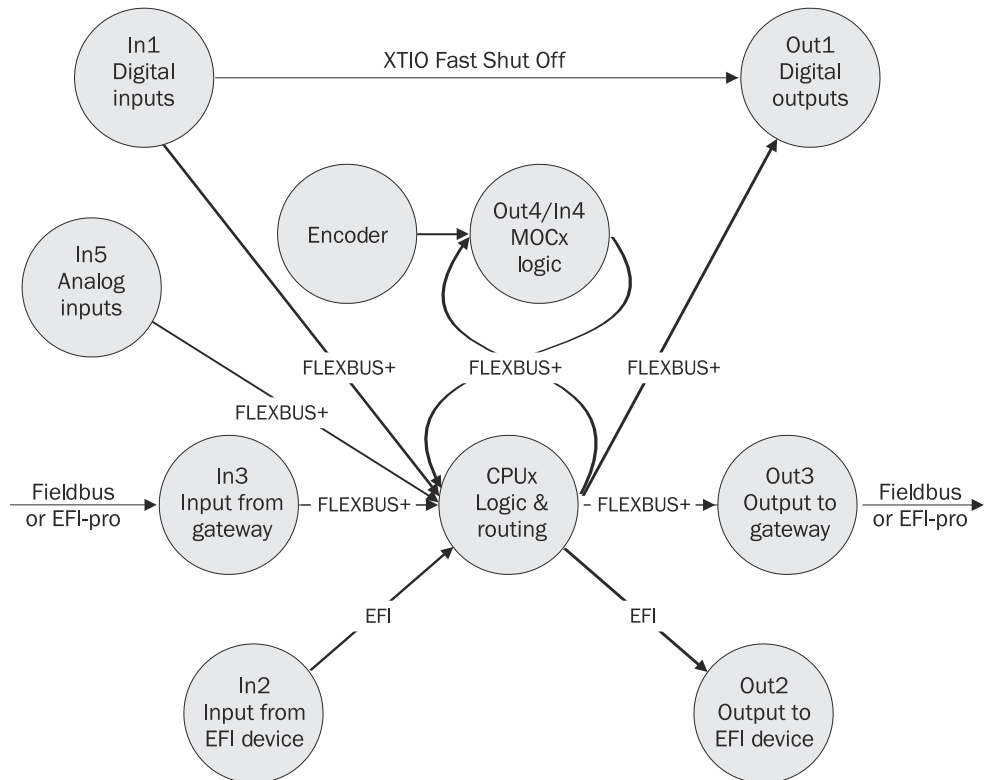

Figure 65: Response times within a Flexi Soft system

Fast shut-off

The fast shut-off function is supported on FX3-XTIO I/O modules. This function enables a response time of 8 ms to be achieved.

⁹⁾ Take the values from the report in the configuration software.

**NOTE**

The Fast Shut Off function only has an effect on the inputs and outputs of the same FX3-XTIO I/O module.

Flexi Link

In a Flexi Link system, the response time is extended for a remote input when compared to a local input by **4.5 ms + 2 × logic execution time** of the Flexi Link system on which the remote input is located.

Flexi Line

If the input is to a far-away station, the response time in a Flexi Line system is extended by

- the input time of the remote station (see table 98, page 134 to see table 105, page 137),
- the logic response time of the station that processes this input (see table 97, page 134: point 2.a)

and

- $N \times (10 \text{ ms} + 2 \times \text{send cycle time})$
where N = the number of connection paths between the stations.

Using the Flexi Line solution within a station increases the response time by one logic execution time of this station.

Optimization of logic execution time

Flexi Soft main modules with firmware \geq V4.00.0 have firmware optimizations which can affect the logic execution time. For compatibility with older models, these optimizations can be activated and/or deactivated by the user.

To benefit from the improved performance of this firmware, select **Logic execution time optimization** option in Flexi Soft Designer and deactivate any functions that are not being used (Flexi Line, Flexi Loop, EFl including Flexi Link).

**NOTE**

The **Optimization of the logic execution time** is always activated in the Safety Designer. Flexi Soft main modules with firmware $<$ V4.00.0 are not supported by Safety Designer.

When optimization is activated, the logic program is executed more quickly in the main module. This can reduce the logic execution time. In complex applications in particular, this reduces the processing time and thus also the response time.

**NOTE**

The minimum logic execution time of a Flexi Soft system is always 4 ms. It cannot be reduced further by means of optimization.

Changes to the logic execution time can mean that changes have to be made to the configuration of the function blocks that are based on the logic execution time.

In order to be able to use the optimization of the logic execution time, you need an FX3-CPUx main module with firmware \geq V4.00.0 (Step 4.xx) and the Flexi Soft Designer version \geq V1.7.1.

More information on optimizing the logic execution time can be found in the “Flexi Soft in the Flexi Soft Designer Configuration Software” operating instructions.

12.2.1 Calculation of the response time

The following table can be used to calculate the response time of associated paths within the Flexi Soft system.

Table 97: Calculation of the maximum response time of the Flexi Soft system in milliseconds

| | | | |
|----------------------------|--|---|------|
| 1. Inputs | Response time of the input under consideration on the signal path | E1 or E2 or E3 or E4 or E5 (see corresponding table) | |
| 2. Logic | a) Response time of the logic of the main module (FX3-CPUx logic) | 2 × logic execution time ¹⁾ Delay with logic application ²⁾ (e.g., switch-on delay or switch-off delay function block) | |
| | b) Response time for routing (only affects A3 output to gateway) | No delay | 0 ms |
| | c) Response time of the fast shut-off logic (only applicable for FX3-XTIO modules) | No delay | 0 ms |
| 3. Outputs | Response time of the output under consideration on the signal path | A1 or A2 or A3 or A4 (see corresponding table) | |
| Total response time | | | |

- 1) Take values from the configuration software report.
- 2) Time values have a tolerance of 10 ms in addition to the logic execution time; i.e., 10 ms must be added to each selected value in order to calculate the response time. For example, in the case of a switch-off delay of 10 ms and a logic execution time of 12 ms, 32 ms must be used for the calculation.

Digital inputs (E1)

Table 98: Calculation of the response time for the digital inputs (E1) in milliseconds

| | | |
|--|--|--------|
| General information | Sensor response time ¹⁾ | |
| General information | Input processing time | 6.5 ms |
| If on/off filter active | + min. filter time ²⁾ | |
| If I1 ... I8 connected to test input X1 ... X8 | + max. OFF-ON delay ³⁾ of the test output used | |
| a) Pressure-sensitive safety mats and bumpers | + test period ³⁾ of the test output; use higher value of the two test outputs | |
| b) Type 4 testable sensors (e.g., L41) | + test period ³⁾ of the test output | |
| c) All other sensors | + test gap ³⁾ of the test output (if test gap ³⁾ > 1 ms) | |
| Total E1 | | |

- 1) Take value from the corresponding operating instructions.
- 2) Switching off is delayed until the signal has been at Low for at least the selected filter time. For FX3-XTIO and FX3-XTDI firmware version < V3.00.0, the filter time is set to a fixed value of 8 ms.
- 3) Take values from the configuration software report.

Digital outputs (A1)

Table 99: Calculation of the response time for the digital outputs (A1) in milliseconds

| | | |
|---|---|--|
| General information | Response time of the actuator ¹⁾ | |
| General information | Output processing time a) From the logic (via FLEXBUS+): + 4.5 ms b) From fast shut-off: + 1.5 ms | |
| If you are using single-channel outputs | Potential switch-off delay in the event of an internal error, depending on whether an extended error detection time has been configured for the switching of capacitive loads: +10 ms or +50 ms ²⁾ | |
| Total A1 | | |

- 1) Take value from the corresponding operating instructions.
- 2) see "Extended error detection time for cross-circuits at outputs Q1 to Q4 on the FX3-XTIO for the switching of increased capacitive loads", page 27 and see "Fault detection time and fault response time when using single-channel outputs on the FX3-XTIO", page 28.

Input from an EFI-enabled device (E2)

Table 100: Calculation of the response time for the input from an EFI-capable device (E2) in milliseconds

| | | |
|---|---|--|
| If EFI functions are used via EFI-enabled devices | Response time of the EFI data source (usually a sensor) for external OSSDs via EFI ¹⁾ or remote Flexi Link station | |
| Constant: | | |
| a) Scanner (e.g., S3000) | + 3.5 ms | |
| b) Light curtain (e.g., C4000) | + 1.5 ms | |
| c) Flexi Link | + 0.5 ms | |
| Total E2 | | |

- 1) Take value from the corresponding operating instructions.

Output to an EFI-enabled device (A2)

Table 101: Calculation of the response time for the output to an EFI-capable device (A2) in milliseconds

| | | |
|---|---|---|
| If EFI functions are used via EFI-enabled devices | Response time of the EFI data recipient (e.g., scanner with protective field switching via EFI) ¹⁾ | |
| Constant: | | EFI cycle time of the EFI data receiver ¹⁾ |
| a) Scanner (e.g., S3000) | + 24 ms | |
| b) Light curtain (e.g., C4000) | + 4 ms | |
| c) Flexi Link | + 4 ms | |
| Total A2 | | |

- 1) Take value from the corresponding operating instructions.

Input from a gateway (E3)

Table 102: Calculation of the response time for the input from a gateway (E3) in milliseconds

| | | |
|---------------------------------------|---|--|
| General information | Fieldbus response time for data to gateway (e.g., from PLC) ¹⁾ | |
| General information | 2 × internal update interval for data from the gateway to the main module ²⁾ | |
| a) EtherCAT gateway | - 3 ms | |
| b) Other gateway | + 5 ms | |
| Deduction when using a second gateway | - 4 ms | |
| Total E3 | | |

- 1) Take value from the corresponding operating instructions.
- 2) The update interval between the main module and a Flexi Soft gateway depends on the quantity of the data to be transmitted and the number of gateways in the system. Take the values from the report in the configuration software.
The update interval is a multiple of 4 ms for every 10 bytes to be transmitted in or out of the gateway if the system only contains one gateway. When two gateways are used, the update interval is a multiple of 8 ms.

Output to a gateway (A3)

Table 103: Calculation of the response time for the output to gateway (A3) in milliseconds

| | | |
|---------------------------------------|---|--|
| General information | Fieldbus response time for data from the gateway (e.g., to the PLC) ¹⁾ | |
| General information | 2 × internal update interval for data from the main module to the gateway ²⁾ | |
| a) EtherCAT gateway | 0 ms | |
| b) Other gateway | + 8 ms | |
| Deduction when using a second gateway | - 4 ms | |
| Total A3 | | |

- 1) Take value from the corresponding operating instructions.
- 2) The update interval between the main module and a Flexi Soft gateway depends on the quantity of the data to be transmitted and the number of gateways in the system. Take the values from the report in the configuration software.
The update interval is a multiple of 4 ms for every 10 bytes to be transmitted in or out of the gateway if the system only contains one gateway. When two gateways are used, the update interval is a multiple of 8 ms.

Input from an FX3-MOCx (E4)

Table 104: Calculation of the response time for the input from an FX3-MOCx (E4) in milliseconds

| | | |
|--|--|------|
| General information | FX3-MOCx logic to FX3-CPUx logic | 0 ms |
| Encoder to FX3-MOCx logic | | |
| a) A/B incremental encoder, sine-cosine encoder (speed value and direction status) ¹⁾ | 8 ms | |
| b) A/B incremental encoder, sine-cosine encoder (position value) | 6 ms | |
| c) SSI master (speed value and direction status) | Max. 4 ms + 1.5 × max. data reception interval ^{1 2)} | |
| d) SSI master (position value) | Max. 4 ms + max. data reception interval ²⁾ | |

| | | |
|--|---|--|
| e) SSI listener (speed value and direction status) | Max. 9 ms + 1.5 × max. data reception interval ^{1 2} | |
| f) SSI listener (position value) | Max. 9 ms + max. data reception interval ² | |
| Error detection times | | |
| a) Sine-cosine analog voltage monitoring, vector length monitoring | 22 ms | |
| b) Sine-cosine analog voltage monitoring, signal deviation monitoring | 6 ms + 1 sine-cosine period, but min. 10 ms | |
| c) Error detection time for ID code monitoring with FX3-EBX1, FX3-EBX3, or FX3-EBX4 encoder/motor feedback connection box ³ | 10 ms | |
| Total E4 | | |

- 1 Since the speed is calculated from the position difference between two detected position values, the speed value is an average of the actual speed within the time interval for position detection. In the case of an assumed linear speed change, the response time for the speed value is therefore greater than the response time for the position value by ½ the time interval for position detection. In the case of A/B incremental encoders and sine-cosine encoders, the time interval for position detection is 4 ms; for SSI encoders it is the selected maximum data reception interval, in a worst-case scenario.
- 2 This is the selected value in the dialog box for the SSI encoder. Take the value from the configuration software report.
- 3 See “Flexi Soft in the Flexi Soft Designer Configuration Software” and “Flexi Soft in the Safety Designer Configuration Software” operating instructions, “Encoder connection type and monitoring of ID identifier” section.

Output to an FX3-MOCx (A4)

Table 105: Calculation of the response time for the output to an FX3-MOCx (A4) in milliseconds

| | | |
|---------------------|----------------------------------|-------------|
| General information | FX3-CPUx logic to FX3-MOCx logic | 4 ms |
| Total A4 | | 4 ms |

Analog inputs (E5)

Table 106: Calculation of the response time for the analog inputs (E5) in milliseconds

| | | |
|--|--|-------|
| Generally | Sensor response time ¹⁾ | |
| Generally | Processing time | 20 ms |
| Generally | Measurement cycle | 4 ms |
| If more than 1 cycle with average value filter | (Number of cycles – 1) × measurement cycle | |
| If sensor AI1 delayed | + delay for sensor AI1 | |
| E5 total | | |

1) Take value from the corresponding operating instructions.

12.2.1.1 Example 1: Calculation of the response time for a Flexi Soft system consisting of an FX3-CPU1 and an FX3-XTIO

| | |
|-----------------------------------|--|
| Digital inputs (E1): | C4000 safety light curtain at FX3-XTIO (e.g., at I5/I6) |
| Digital outputs (A1): | Robot, dual-channel, at FX3-XTIO (e.g., at Q3/Q4) |
| Input of EFI-enabled device (E2): | C4000 receiver (stand-alone) at FX3-CPU1 (e.g., at EF11_A) |

Two paths must be considered and calculated separately:

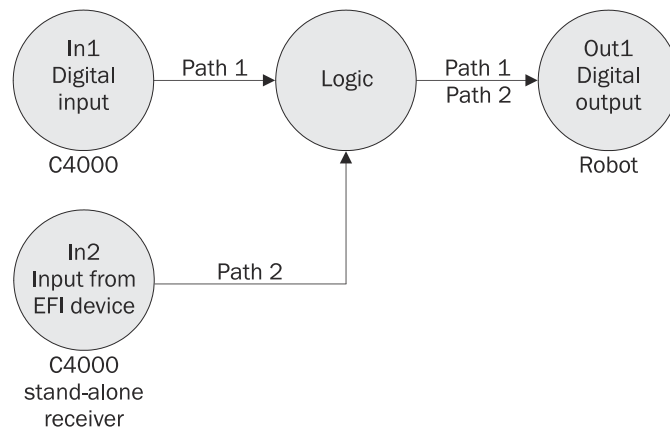

Figure 66: Response times within a Flexi Soft system

Digital inputs (E1)

Table 107: Example for the calculation of the response time for the digital inputs (E1)

| | | |
|--|--|----------------|
| General information | C4000 response time | 14.0 ms |
| General information | Input processing time | 6.5 ms |
| If on-off filter active | + min. filter time ¹⁾ | - |
| If I1 ... I8 connected to test input X1 ... X8 | + max. OFF-ON delay ²⁾ of the test input used | - |
| a) Pressure-sensitive safety mats and bumpers | + test period ²⁾ of the test output, higher value of the two test outputs | - |
| b) Type 4 testable sensors (e.g., L41) | + test period ²⁾ of the test output | - |
| c) All other sensors | + test gap ²⁾ of the test output (if test gap ²⁾ > 1 ms) | - |
| If you are using single-channel outputs | | - |
| Total E1 | | 20.5 ms |

- 1) Switching off is delayed until the signal has been at Low for at least the selected filter time. For FX3-XTIO and FX3-XTDI firmware version < V3.00.0, the filter time is set to a fixed value of 8 ms.
- 2) Take the values from the report in the configuration software.

Digital outputs (A1) on path 1

Table 108: Example for the calculation of the response time for the digital outputs (A1) on path 1

| | | |
|---|---|----------------|
| General information | Robot response time | 40.0 ms |
| General information | Output processing time | 4.5 ms |
| If you are using single-channel outputs | Potential switch-off delay in the event of an internal error, depending on whether an extended error detection time has been configured for the switching of capacitive loads: +10 ms or +50 ms ¹⁾ | - |
| Total A1 | | 44.5 ms |

- 1) see "Extended error detection time for cross-circuits at outputs Q1 to Q4 on the FX3-XTIO for the switching of increased capacitive loads", page 27 and see "Fault detection time and fault response time when using single-channel outputs on the FX3-XTIO", page 28.

Response time of path 1

Table 109: Example for the calculation of the response time of path 1 of a Flexi Soft system

| | | | |
|--------------------------------------|---|--------------------------------|----------------|
| 1. Inputs | Response time of the input under consideration on path 1 | E1 | 20.5 ms |
| 2. Logic | Logic response time | 2 × logic execution time | 8.0 ms |
| | | Delay due to logic application | - |
| 3. Outputs | Response time of the output under consideration on path 1 | A1 | 44.5 ms |
| Total response time of path 1 | | | 73.0 ms |

Input from an EFI-enabled device (E2)

Table 110: Example for the calculation of the response time for the input from an EFI-enabled device (E2)

| | | |
|---|---|----------------|
| If EFI functions are used via EFI-enabled devices | Response time of the EFI data source (C4000 receiver (stand-alone)) | 12.0 ms |
| | Constant (C4000) | 1.5 ms |
| Total E2 | | 13.5 ms |

Digital outputs (A1) on path 2

Table 111: Example for the calculation of the response time for the digital outputs (A1) on path 2

| | | |
|---------------------|------------------------|----------------|
| General information | Robot response time | 40.0 ms |
| General information | Output processing time | 4.5 ms |
| Total A1 | | 44.5 ms |

Response time of path 2

Table 112: Example for the calculation of the response time of path 2 of a Flexi Soft system

| | | | |
|--------------------------------------|---|--------------------------------|----------------|
| 1. Inputs | Response time of the input under consideration on path 2 | E2 | 13.5 ms |
| 2. Logic | Logic response time | 2 × logic execution time | 8.0 ms |
| | | Delay due to logic application | - |
| 3. Outputs | Response time of the output under consideration on path 2 | A1 | 44.5 ms |
| Total response time of path 2 | | | 66.0 ms |

12.2.1.2 Example 2: Calculation of the response time for a Flexi Link system

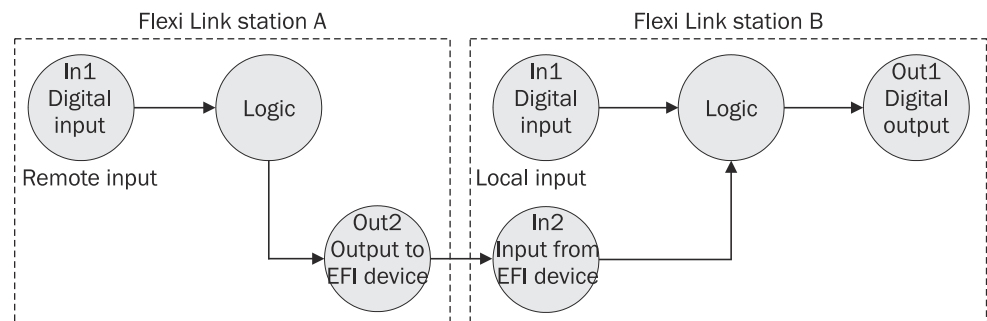

Figure 67: Response times within a Flexi Link system

Flexi Link station A

Logic execution time = 4 ms

Flexi Link station B

Logic execution time = 8 ms

Digital inputs (E1) from station A

Table 113: Example for the calculation of the response time for the digital inputs (E1) from station A

| | | |
|--|----------------------------------|---------------|
| General information | Tactile sensor | 0 ms |
| General information | Input processing time | 6.5 ms |
| If on-off filter active | + min. filter time ¹⁾ | - |
| If I1 ... I8 connected to test input X1 ... X8 | | - |
| Total E1 | | 6.5 ms |

¹⁾ Switching off is delayed until the signal has been at Low for at least the selected filter time. For FX3-XTIO and FX3-XTDI firmware version < V3.00.0, the filter time is set to a fixed value of 8 ms.

Output to an EFI-enabled device (A2) from station A

Table 114: Example for the calculation of the response time for the output to an EFI-enabled device (A2) from station A

| | | |
|---|--|-------------|
| If EFI functions are used via EFI-enabled devices | Response time of the EFI data recipient (see corresponding table for Flexi Link station B) | - |
| | Constant (Flexi Link) | 4 ms |
| Total A2 | | 4 ms |

¹⁾ Switching off is delayed until the signal has been at Low for at least the selected filter time. For FX3-XTIO and FX3-XTDI firmware version < V3.00.0, the filter time is set to a fixed value of 8 ms.

Total response time of station A

Table 115: Example for the calculation of the total response time of station A (from remote input to EFI) in a Flexi Link system

| | | | |
|--|--|--------------------------------|----------------|
| 1. Inputs | Response time of the input under consideration on the signal path | E1 | 6.5 ms |
| 2. Logic | Logic response time | 2 × logic execution time | 8.0 ms |
| | | Delay due to logic application | - |
| 3. Outputs | Response time of the output under consideration on the signal path | A2 | 4.0 ms |
| Total response time (from remote input to EFI) of station A | | | 18.5 ms |

Input from an EFI-enabled device (E2) from station B

Table 116: Example for the calculation of the response time for the input from an EFI-enabled device (E2) from station B

| | | |
|---|---|----------------|
| If EFI functions are used via EFI-enabled devices | Response time of the EFI data source (see corresponding table for Flexi Link station A) | 18.5 ms |
| | Constant (Flexi Link) | 0.5 ms |
| Total E2 | | 19.0 ms |

Digital outputs (A1) from station B

Table 117: Example for the calculation of the response time for the digital inputs (E1) from station B

| | | |
|---------------------|-------------------------------|----------------|
| General information | Response time of the actuator | 40.0 ms |
| General information | Output processing time | 4.5 ms |
| Total A1 | | 44.5 ms |

Total response time of station B

Table 118: Example for the calculation of the total response time of station B (remote input to local output) in a Flexi Link system

| | | | |
|---|--|--------------------------------|----------------|
| 1. Inputs | Response time of the input under consideration on the signal path | E2 | 19.0 ms |
| 2. Logic | Logic response time | 2 × logic execution time | 16.0 ms |
| | | Delay due to logic application | - |
| 3. Outputs | Response time of the output under consideration on the signal path | A1 | 44.5 ms |
| Total response time (remote input to local output) of station B | | | 79.5 ms |

12.3 Data sheet

12.3.1 Main modules CPU0, CPU1, CPU2 and CPU3

Safety-related parameters

The data apply to an ambient temperature of +40 °C.

Table 119: Safety-related parameters CPUx

| | CPU0 | CPU1/2/3 |
|---|-------------------------|-------------------------|
| Safety integrity level (IEC 61508) | SIL 3 | |
| Safety integrity level (IEC 62061) | | |
| Category (ISO 13849) | Category 4 | |
| Performance level (ISO 13849) | PL e | |
| PFH _D | 1.07 × 10 ⁻⁹ | 1.69 × 10 ⁻⁹ |
| PFH _D for Flexi-Line station ¹⁾ | - | 0.40 × 10 ⁻⁹ |
| PFD _{avg} | 5 × 10 ⁻⁵ | |
| PFD _{avg} for Flexi-Line station ¹⁾ | - | 5 × 10 ⁻⁵ |
| T _M (mission time, ISO 13849) | 20 years | |

¹⁾ Valid for a FX3-CPU3 main module which is only used for the transfer of information via Flexi Line.

General data

Table 120: General data CPUx

| | CPU0, CPU1, CPU2, CPU3 |
|------------------------------|------------------------|
| Protection class (IEC 61140) | III |
| Immunity to interference | EN 61000-6-2 |
| Emitted interference | EN 61000-6-4 |

Interfaces

Table 121: Interfaces FX3-CPU0, FX3-CPU1, FX3-CPU2 and FX3-CPU3

| | FX3-CPU0 | FX3-CPU1/2/3 |
|--|-------------------------|---|
| Number of EFI interfaces | 0 | 2 |
| Number of Flexi-Line interfaces | 0 | FX3-CPU1/2: 0 FX3-CPU3: 1 |
| Data interface | Internal bus (FLEXBUS+) | |
| Configuration interface | RS-232 | FX3-CPU1/2: RS-232 FX3-CPU3: RS-232, USB |
| Connection technology RS-232 | M8, 4-pin | |
| Connection technology USB | - | FX3-CPU1/2: - FX3-CPU3: USB Mini-B, 5-pin |
| EFI and Flexi Line connection technology | - | Dual level spring terminals |
| EFI and Flexi Line conductor cross section | - | Single-wire or fine-stranded wire: 0.2 ... 1.5 mm ² Stranded wire with ferrule: a) With plastic ferrule max. 0.75 mm ² b) Without plastic ferrule max. 1.5 mm ² AWG to UL/CUL: 24 ... 16 |

Electrical data

Table 122: Power supply unit (A1, A2) for CPU0, CPU1, CPU2 and CPU3 (via system plug MPL0 or MPL1)

| | CPU0, CPU1, CPU2, CPU3 |
|--|---|
| Supply voltage | 24 V DC (16.8 V DC ... 30 V DC) |
| Supply voltage for UL/CSA applications | +24 V DC |
| Type of supply voltage | PELV or SELV The supply current for the module must be limited externally to max. 4 A – either by the power supply unit used, or by means of a fuse. |
| Short-circuit protection | 4 A gG (with trigger characteristics B or C) |
| Overvoltage category | II (EN 61131-2) |
| Power consumption | Max. 2.5 W |
| Power loss | |
| Power-up delay | Max. 18 s |
| Connection type | Screw terminals |
| Wire cross-section | Single-wire or fine-stranded wire: 0.14 ... 2.5 mm ² AWG to UL/CUL: 26 ... 14 |

Mechanical data

Table 123: Mechanical data CPUx

| | CPU0, CPU1, CPU2, CPU3 |
|------------------------|------------------------------|
| Dimensions (W × H × D) | 22.5 mm × 96.5 mm × 120.6 mm |

| | CPU0, CPU1, CPU2, CPU3 |
|--------|--|
| Weight | 111 g (± 5%) FX3-CPU1/2: 119 g (± 5%) FX3-CPU3: 133 g (± 5%) |

Ambient data

Table 124: Ambient data CPUx

| | CPU0, CPU1, CPU2, CPU3 |
|---|---|
| Enclosure rating (IEC 60529) | IP20 |
| Ambient operating temperature (UL/CSA: surrounding air temperature) | -25 ... +55 °C |
| Storage temperature | -25 ... +70 °C |
| Air humidity | ≤ 95%, non-condensing |
| Operating altitude | Max. 2,000 m above sea level (80 kPa) |
| Vibration resistance | 5–150 Hz / 1 G (EN 60068-2-6) 10–500 Hz / 3 G _{rms} (EN 60068-2-64) |
| Shock resistance, continuous shock | 15 g, 11 ms (EN 60068-2-27) |
| Shock resistance, single shock | 30 g, 11 ms (EN 60068-2-27) |

12.3.2 I/O module XTIO

Safety-related parameters

The data apply to an ambient temperature of +40 °C.

Table 125: Safety-related parameters XTIO

| | XTIO |
|--|-----------------------------|
| Safety integrity level (IEC 61508) Safety integrity level (IEC 62061) | SIL 3 |
| Category (ISO 13849) ¹⁾ | |
| For single-channel outputs with test pulses activated on all safety outputs (Q1 ... Q4) | Category 4 ²⁾ |
| For single-channel outputs with test pulses deactivated on this or on any other safety output (Q1 ... Q4) | Category 3 ^{2) 3)} |
| For dual-channel outputs with or without test pulses deactivated on this or on any other safety output (Q1 ... Q4) | Category 4 ^{3) 4)} |
| Performance level (ISO 13849) | PL e |
| PFH _D ¹⁾ | |
| For single-channel outputs | 4.8×10^{-9} |
| For dual-channel outputs | 0.9×10^{-9} |
| PFD _{avg} ¹⁾ | |
| For single-channel outputs | 4.2×10^{-4} |
| For dual-channel outputs | 5×10^{-5} |

| | XTIO |
|--|------------------------|
| T _M (mission time, ISO 13849) | 20 years ³⁾ |

- 1) Valid for single-channel and dual-channel inputs.
- 2) When using single-channel outputs: Use protected or separate cabling for these safety outputs because while a short-circuit to 24 V can be detected, no other means of switching off the device exists.
- 3) Since safety outputs without test pulses are used, at least once a year either all safety outputs without test pulses must be switched off at the same time for at least one second or the Flexi Soft system must be restarted by switching off the voltage supply.
- 4) When using safety outputs without test pulses: Use protected or separate cabling for the safety outputs for which test pulses are deactivated because a short-circuit to 24 V cannot be detected when the safety output is High. This could impair the ability of the other safety outputs to be switched off by reverse currents in the event an internal hardware error is detected.

General data

Table 126: General data XTIO

| | XTIO |
|------------------------------|---|
| Protection class (IEC 61140) | III |
| Immunity to interference | EN 61000-6-2 |
| Emitted interference | EN 61000-6-4 |
| Connection type | Dual-level spring terminals |
| Wire cross-section | Single-wire or fine-stranded wire: 0.2 ... 1.5 mm ² Stranded wire with ferrule: a) With plastic ferrule max. 0.75 mm ² b) Without plastic ferrule max. 1.5 mm ² AWG to UL/CUL: 24 ... 16 |
| Power consumption | Max. 2.2 W |
| Power loss | |

Interfaces

Table 127: Interfaces FX3-XTIO

| | XTIO |
|----------------|-------------------------|
| Data interface | Internal bus (FLEXBUS+) |

Electrical data

Table 128: Power supply unit (A1, A2) for XTIO

| | XTIO |
|--|---|
| Supply voltage | 24 V DC (16.8 ... 24 ... 30 V DC) |
| Supply voltage for UL/CSA applications | +24 V DC |
| Type of supply voltage | PELV or SELV The supply current for the module must be limited externally to max. 4 A – either by the power supply unit used, or by means of a fuse. |
| Short-circuit protection | 4 A gG (with trigger characteristics B or C) |
| Power consumption | Max. 120 W (30 V × 4 A), determined by the load on the outputs Q1 to Q4, plus max. 1 W power consumption by the internal circuit |
| Power-up delay | Max. 18 s |

Table 129: Safety inputs (I) XTIO

| | XTIO |
|------------------|------|
| Number of inputs | 8 |

| | XTIO |
|---|--|
| Input voltage High | 13 ... 30 V DC ¹⁾ |
| Input voltage Low | -5 ... +5 V DC |
| Input current High | 2.4 ... 3.8 mA |
| Input current Low | -2.5 ... +2.1 mA |
| Reverse current at input in case of loss of ground connection ²⁾ | |
| Hardware version < V1.10 (FX3-XTIO Step 1.xx) ³⁾ | Max. 20 mA 1.5 kΩ effective resistance from the voltage supply to the input |
| Hardware version ≥ V1.10 (FX3-XTIO Step 2.xx) ³⁾ | Max. 2 mA |
| Switching current (when mechanical contacts are connected) | 14.4 mA at 5 V 3 mA at 24 V |
| Input pulse filter (pulses within these limits do not have any effect) | |
| Pulse width | Max. 0.9 ms |
| Pulse period | Min. 4 ms |
| Input capacitance | Max. 10 nF + 10% |
| Discrepancy time | 4 ms ... 30 s, configurable |

¹⁾ At temperatures below 0 °C the input level may be higher (max. 14.5 V).

²⁾ Do not connect any other safety inputs in parallel if the reverse current could lead to a High state on the other input.

³⁾ The hardware version of the Flexi Soft module can be found in the configuration software in the online state or in the report if the system was previously online.

Table 130: Test outputs (X) XTIO

| | XTIO |
|-------------------------------|---|
| Number of outputs | 2 (with 2 test pulse generators) |
| Type of output | PNP semiconductor, short-circuit protected, cross-circuit monitored |
| Output voltage High | 15 ... 30 V DC (max. 1.8 V drop to terminal A1 of the main module) |
| Output resistance Low | ≤ 33 Ω + 10%, current limited to approx. 10 mA |
| Output current | Max. 120 mA at each test output (X1 or X2). This makes max. 8 testable sensor cascades per module possible with max. 30 mA each. The total current of the Flexi Soft systems for all outputs (X1 ... X8 and XY1 ... XY2) must not exceed 1.28 A. This corresponds, for example, to a maximum of 32 testable sensor cascades each with 30 mA plus 64 tactile sensors on the inputs of expansion modules each with 5 mA. |
| Test pulse rate (test period) | 40 ... 1,000 ms, configurable |
| Test pulse width (test gap) | 1 ... 100 ms, configurable |
| Load capacity | 1 μF for a test gap ≥ 4 ms 0.5 μF for a test gap of 1 ms |
| Conductor resistance | < 100 Ω |

Table 131: Safety outputs (Q) XTIO

| | XTIO |
|-------------------|--|
| Number of outputs | 4 |
| Type of output | PNP semiconductor, short-circuit protected |

| XTIO | |
|--|--|
| Output voltage High | 16 ... 30 V DC (max. 0.8 V drop to terminal A1 of this module) |
| Leakage current Low | |
| Normal operation | Max. 0.1 mA |
| In the event of an error ¹⁾ , Hardware version < V1.10 (FX3-XTIO Step 1.xx) | Max. 1.6 mA |
| In the event of an error ¹⁾ , Hardware version ≥ V1.10 (FX3-XTIO Step 2.xx) | Max. 2.0 mA |
| Output current | Max. 2.0 A |
| Sum current I _{sum} | |
| T _U ≤ 45 °C | Max. 4.0 A |
| T _U ≤ 55 °C | Max. 3.2 A |
| UL/CSA applications | Max. 3.2 A |
| Test pulse duration (test gap) ²⁾ | < 650 μs or deactivated |
| Test pulse rate (test period) | Min. 200 ms |
| Load capacity | ≤ 0.5 μF |
| Conductor resistance ³⁾ | Max. 5 Ω (e.g., 100 m × 1.5 mm ² = 1.2 Ω) |
| Max. permitted coil energy without external protection elements ⁴⁾ | |
| Hardware version V1.00 | 0.22 J |
| Hardware version ≥ V1.01 | 0.37 J |
| Response time | Depending on the logic configuration, for details see: see table 97, page 134 |
| Synchronicity of outputs Qx within a Flexi Soft station (time delay) ⁵⁾ | Max. 1 ms |
| Possible switching to High in the event of an internal hardware error | 10 ms or 50 ms, Details: see "Fault detection time and fault response time when using single-channel outputs on the FX3-XTIO", page 28 |

- 1) In the event of an error (GND line open circuit) and with a load resistance of at least 2.5 kΩ, no more than the specified leakage current flows on the safety output. For lower load resistances, the leakage current may be greater; however, the output voltage will be < 5 V in this case. A downstream device, for example a relay or a FPLC (fail-safe programmable logic controller) must detect this state as Low.
- 2) When activated, the outputs are tested regularly (brief switching to Low). When selecting the downstream control elements, ensure that the test pulses with the specified parameters do not result in a switch-off, or deactivate the test pulses on the outputs yourself.
- 3) Make sure to limit the conductor resistance of the individual cables to the downstream controller to this value in order to ensure that a short-circuit between the outputs is safely detected. (See also EN 60204 Electrical equipment of machines, Part 1: General requirements.)
- 4) Examples of the maximum resulting coil induction depending on coil current:
 - Hardware version V1.00: 1,760 mH @ 0.5 A, 440 mH @ 1 A, 110 mH @ 2 A
 - Hardware version V1.01: 2,960 mH @ 0.5 A, 740 mH @ 1 A, 185 mH @ 2 A

For inductive loads (e.g. contactors, relays and valves), no external protective elements are required if this maximum coil energy is not exceeded.

RC elements parallel to the inductive load should not be used because these can create an oscillating circuit that causes an overshoot in the positive voltage range once the induction voltage has decayed and thereby trigger a cross-circuit error. The tolerated time for the overshoot (> 3.5 V) must be observed:

 - Firmware version ≤ V2.10.0: < 1 ms
 - Firmware version V2.11.0: < 3 ms
 - Firmware version ≥ V3.00.0: < 3 ms or < 43 ms if an extended error detection time for switching capacitive loads has been configured

The overshoot can be reduced if necessary using an external parallel resistance.

- 5) This includes switching off in the event of an error: In the case of a dual-channel output, both channels switch off within this time in the event of an error.

Mechanical data

Table 132: Mechanical data XTIO

| | XTIO |
|------------------------|------------------------------|
| Dimensions (W × H × D) | 22.5 mm × 96.5 mm × 120.6 mm |
| Weight | 164 g (± 5%) |

Ambient data

Table 133: Ambient data XTIO

| | XTIO |
|---|---|
| Enclosure rating (IEC 60529) | IP20 |
| Ambient operating temperature (UL/CSA: surrounding air temperature) | -25 ... +55 °C |
| Storage temperature | -25 ... +70 °C |
| Air humidity | ≤ 95%, non-condensing |
| Operating altitude | Max. 2,000 m above sea level (80 kPa) |
| Vibration resistance | 5–150 Hz / 1 G (EN 60068-2-6) 10–500 Hz / 3 G _{rms} (EN 60068-2-64) |
| Shock resistance, continuous shock | 15 g, 11 ms (EN 60068-2-27) |
| Shock resistance, single shock | 30 g, 11 ms (EN 60068-2-27) |

12.3.3 I/O module XTDI

Safety-related parameters

The data apply to an ambient temperature of +40 °C.

Table 134: Safety parameters XTDI

| | XTDI |
|--|------------------------|
| Safety integrity level (IEC 61508) Safety integrity level (IEC 62061) | SIL 3 |
| Category (ISO 13849) | Category 4 |
| Performance level (ISO 13849) | PL e |
| PFH _D | 0.4 × 10 ⁻⁹ |
| PFD _{avg} | 3 × 10 ⁻⁵ |
| T _M (mission time, ISO 13849) | 20 years |

General data

Table 135: General data XTDI

| | XTDI |
|------------------------------|-----------------------------|
| Protection class (IEC 61140) | III |
| Immunity to interference | EN 61000-6-2 |
| Emitted interference | EN 61000-6-4 |
| Connection type | Dual level spring terminals |

| | XTDI |
|--------------------|---|
| Wire cross-section | Single-wire or fine-stranded wire: 0.2 ... 1.5 mm ² Stranded wire with ferrule: a) With plastic ferrule max. 0.75 mm ² b) Without plastic ferrule max. 1.5 mm ² AWG to UL/CUL: 24 ... 16 |
| Power consumption | Max. 2 W |
| Power loss | |

Interfaces

Table 136: Interfaces XTDI

| | XTDI |
|----------------|-------------------------|
| Data interface | Internal bus (FLEXBUS+) |

Electrical data

Table 137: Safety inputs (I) XTDI

| | XTDI |
|---|--|
| Number of inputs | 8 |
| Input voltage High | 13 ... 30 V DC ¹⁾ |
| Input voltage Low | -5 ... +5 V DC |
| Input current High | 2.4 ... 3.8 mA |
| Input current Low | -2.5 ... +2.1 mA |
| Reverse current at input in case of loss of ground connection ²⁾ | |
| Hardware version < V1.10(FX3-XTDI Step 1.xx) ³⁾ | Max. 20 mA 1.5 kΩ effective resistance from the voltage supply to the input |
| Hardware version ≥ V1.10(FX3-XTDI Step 2.xx) ³⁾ | Max. 2 mA |
| Switching current (when mechanical contacts are connected) | 14.4 mA at 5 V 3 mA at 24 V |
| Input capacitance | Max. 10 nF +10% |
| Discrepancy time | 4 ms ... 30 s, configurable |

- 1) At temperatures below 0 °C the input level may be higher (max. 14.5 V).
- 2) Do not connect any other safety inputs in parallel if the reverse current could lead to a High state on the other input.
- 3) The hardware version of the Flexi Soft module can be found in the configuration software in the online state or in the report if the system was previously online.

Table 138: Test outputs (X) XTDI

| | XTDI |
|-----------------------|---|
| Number of outputs | 8 (with 2 test pulse generators) |
| Type of output | PNP semiconductor, short-circuit protected, cross-circuit monitored |
| Output voltage High | 15 ... 30 V DC (max. 1.8 V drop to terminal A1 of the main module) |
| Output resistance Low | ≤ 33 Ω + 10%, current limited to approx. 10 mA |

| | XTDI |
|-------------------------------|--|
| Output current | Max. 120 mA at each of the two test pulse generators (X1 / X3 / X5 / X7 or X2 / X4 / X6 / X8). This makes max. 8 testable sensor cascades per module possible with max. 30 mA each. The total current of the Flexi Soft systems for all outputs (X1 ... X8 and XY1 ... XY2) must not exceed 1.28 A. This corresponds, for example, to a maximum of 32 testable sensor cascades each with 30 mA plus 64 tactile sensors on the inputs of expansion modules each with 5 mA. |
| Test pulse rate (test period) | 40 ... 1,000 ms, configurable |
| Test pulse width (test gap) | 1 ... 100 ms, configurable |
| Load capacity | 1 μ F for a test gap \geq 4 ms 0.5 μ F for a test gap of 1 ms |
| Conductor resistance | < 100 Ω |

Mechanical data

Table 139: Mechanical data XTDI

| | XTDI |
|------------------------|------------------------|
| Dimensions (W × H × D) | 22.5 × 96.5 × 120.6 mm |
| Weight | 139 g (\pm 5%) |

Ambient data

Table 140: Ambient data XTDI

| | XTDI |
|---|---|
| Enclosure rating (IEC 60529) | IP20 |
| Ambient operating temperature (UL/CSA: surrounding air temperature) | -25 ... +55 °C |
| Storage temperature | -25 ... +70 °C |
| Air humidity | \leq 95%, non-condensing |
| Operating altitude | Max. 2,000 m above sea level (80 kPa) |
| Vibration resistance | 5–150 Hz / 1 G (EN 60068-2-6) 10–500 Hz / 3 G _{rms} (EN 60068-2-64) |
| Shock resistance, continuous shock | 15 g, 11 ms (EN 60068-2-27) |
| Shock resistance, single shock | 30 g, 11 ms (EN 60068-2-27) |

12.3.4 I/O module XTDS

Safety-related parameters

The data apply to an ambient temperature of +40 °C.

The safety-related parameters do not apply to outputs XY1, XY2 and Y3-Y6.

Table 141: Safety-related parameters XTDS

| | XTDS |
|--|------------|
| Safety integrity level (IEC 61508) Safety integrity level (IEC 62061) | SIL 3 |
| Category (ISO 13849) | Category 4 |
| Performance level (ISO 13849) | PL e |

| | XTDS |
|--|------------------------|
| PFH _D | 0.4 × 10 ⁻⁹ |
| PFD _{avg} | 3 × 10 ⁻⁵ |
| T _M (mission time, ISO 13849) | 20 years |

General data

Table 142: General data XTDS

| | XTDS |
|------------------------------|---|
| Protection class (IEC 61140) | III |
| Immunity to interference | EN 61000-6-2 |
| Emitted interference | EN 61000-6-4 |
| Connection type | Dual level spring terminals |
| Wire cross-section | Single-wire or fine-stranded wire: 0.2 ... 1.5 mm ² Stranded wire with ferrule: a) With plastic ferrule max. 0.75 mm ² b) Without plastic ferrule max. 1.5 mm ² AWG to UL/CUL: 24 ... 16 |
| Data interface | Internal bus (FLEXBUS+) |
| Power consumption | Max. 1.5 W |
| Power loss | |

Interfaces

Table 143: Interfaces XTDS

| | XTDS |
|----------------|-------------------------|
| Data interface | Internal bus (FLEXBUS+) |

Electrical data

Table 144: Power supply unit (A1, A2) for XTDS

| | XTDS |
|--|---|
| Supply voltage | 24 V DC (16.8 ... 24 ... 30 V DC) |
| Supply voltage for UL/CSA applications | +24 V DC |
| Type of supply voltage | PELV or SELV The supply current for the module must be limited externally to max. 4 A – either by the power supply unit used, or by means of a fuse. |
| Short-circuit protection | 4 A gG (with trigger characteristics B or C) |
| Power consumption | Max. 60 W (30 V × 2 A), determined by the load on outputs Y3 to Y6 |
| Power-up delay | Max. 18 s |

Table 145: Safety inputs (I) XTDS

| | XTDS |
|--------------------|------------------------------|
| Number of inputs | 8 |
| Input voltage High | 13 ... 30 V DC ¹⁾ |
| Input voltage Low | -5 ... +5 V DC |
| Input current High | 2.4 ... 3.8 mA |
| Input current Low | -2.5 ... +2.1 mA |

| | XTDS |
|---|--------------------------------|
| Reverse current at input in case of loss of ground connection ²⁾ | Max. 2 mA |
| Switching current (when mechanical contacts are connected) | 14.4 mA at 5 V 3 mA at 24 V |
| Input capacitance | Max. 15 nF + 10% |
| Discrepancy time | 4 ms ... 30 s, configurable |

1) At temperatures below 0 °C the input level may be higher (max. 14.5 V).

2) Do not connect any other safety inputs in parallel if the reverse current could lead to a High state on the other input.

Table 146: Outputs XY of the XTDS when used as test outputs

| | XTDS |
|-------------------------------|--|
| Number of outputs | 2 (with 2 test pulse generators) |
| Type of output | PNP semiconductor, short-circuit protected |
| Output voltage High | 15 ... 30 V DC (max. 1.8 V drop to terminal A1 of the main module) |
| Output resistance Low | ≤ 33 Ω + 10%, current limited to approx. 10 mA |
| Output current | Max. 120 mA at each of the two test pulse generators (XY1 or XY2). This makes max. 8 testable sensor cascades per module possible with max. 30 mA each. The total current of the Flexi Soft systems for all outputs (X1 ... X8 and XY1 ... XY2) must not exceed 1.28 A. This corresponds, for example, to a maximum of 32 testable sensor cascades each with 30 mA plus 64 tactile sensors on the inputs of expansion modules each with 5 mA. |
| Test pulse rate (test period) | 40 ... 1,000 ms, configurable |
| Test pulse width (test gap) | 1 ... 100 ms, configurable |
| Load capacity | 1 µF for a test gap ≥ 4 ms 0.5 µF for a test gap of 1 ms |
| Conductor resistance | < 100 Ω |

Table 147: Non-safety outputs (Y3 ... Y6, XY1 and XY2 when used as non-safety outputs) XTDS

| | XTDS |
|---|--|
| Number of non-safety outputs | 4 (6) |
| Type of output | PNP semiconductor, short-circuit protected |
| Output voltage High | 16 ... 30 V DC (max. 0.8 V drop to terminal A1 of this module) |
| Leakage current Low | |
| Normal operation | Max. 0.1 mA |
| Error case ¹⁾ | Max. 1.0 mA |
| Output current | |
| XY1, XY2 | Max. 120 mA |
| Y3 ... Y6 | Max. 0.5 A |
| Max. permitted coil energy without external protection elements ²⁾ | 0.37 J |

| | XTDS |
|---------------|---|
| Response time | Depending on the logic configuration, for details see: see table 97, page 134 |

- 1) In the event of an error (GND line open circuit) and with a load resistance of at least 2.5 kΩ, no more than the specified leakage current flows on the output. For lower load resistances, the leakage current may be greater; however, the output voltage will be < 5 V in this case. A downstream device, for example a relay or a FPLC (fail-safe programmable logic controller) must detect this state as Low.
- 2) Example of resulting maximum coil induction: 2,960 mH @ 0.5 A.

Mechanical data

Table 148: Mechanical data XTDS

| | XTDS |
|------------------------|------------------------------|
| Dimensions (W × H × D) | 22.5 mm × 96.5 mm × 120.6 mm |
| Weight | 139 g (± 5%) |

Ambient data

Table 149: Ambient data XTDS

| | XTDS |
|---|---|
| Enclosure rating (IEC 60529) | IP20 |
| Ambient operating temperature (UL/CSA: surrounding air temperature) | -25 ... +55 °C |
| Storage temperature | -25 ... +70 °C |
| Air humidity | ≤ 95%, non-condensing |
| Operating altitude | Max. 2,000 m above sea level (80 kPa) |
| Vibration resistance | 5–150 Hz / 1 G (EN 60068-2-6) 10–500 Hz / 3 G _{rms} (EN 60068-2-64) |
| Shock resistance, continuous shock | 15 g, 11 ms (EN 60068-2-27) |
| Shock resistance, single shock | 30 g, 11 ms (EN 60068-2-27) |
| Immunity to interference | EN 61000-6-2 |

12.3.5 I/O module STIO

General data

Table 150: General data STIO

| | STIO |
|------------------------------|---|
| Protection class (IEC 61140) | III |
| Immunity to interference | EN 61000-6-2 |
| Emitted interference | EN 61000-6-4 |
| Connection type | Dual level spring terminals |
| Wire cross-section | Single-wire or stranded: 0.2 ... 1.5 mm ² Stranded wire with ferrule: a) With plastic ferrule max. 0.75 mm ² b) Without plastic ferrule max. 1.5 mm ² AWG to UL/CUL: 24 ... 16 |
| Power consumption | Max. 1.5 W |
| Power loss | |

Interfaces

Table 151: Interfaces STIO

| | STIO |
|----------------|-------------------------|
| Data interface | Internal bus (FLEXBUS+) |

Electrical data

Table 152: Power supply unit (A1, A2) for STIO

| | STIO |
|------------------------------------|--|
| Supply voltage | 24 V DC (16.8 ... 24 ... 30 V DC) |
| Supply voltage UL/CSA applications | 24 V DC |
| Type of supply voltage | PELV or SELV The supply current for the module must be limited externally to max. 4 A – either by the power supply unit used or using a fuse. |
| Short-circuit protection | 4 A gG (with tripping characteristics B or C) |
| Power consumption | Max. 120 W (30 V × 4 A), determined by the load at outputs Y1 to IY8 |
| Power-up delay | Max. 18 s |

Table 153: Input circuit (I1 ... IY8) STIO

| | STIO |
|--|--------------------------------|
| Number of non-safety inputs | 6 (8) |
| Input voltage High | 13 ... 30 V DC ¹ |
| Input voltage Low | -5 ... +5 V DC |
| Input current High | 2.4 ... 3.8 mA |
| Input current Low | -2.5 ... +2.1 mA |
| Switching current (when mechanical contacts are connected) | 14.4 mA at 5 V 3 mA at 24 V |
| Input capacitance | Max. 15 nF + 10% |
| Discrepancy time | 4 ms ... 30 s, configurable |

¹ At temperatures below 0 °C the input level may be higher (max. 14.5 V).

Table 154: Non-safety outputs (Y1 ... Y6 as well as IY7 and IY8) of the STIO

| | STIO |
|---|--|
| Number of non-safety outputs | 6 (8) |
| Type of output | PNP semiconductor, short-circuit protected |
| Output voltage High | 16 ... 30 V DC (max. 0.8 V drop to terminal A1 of this module) |
| Leakage current Low | |
| Normal operation | Max. 0.1 mA |
| Error case ¹⁾ | Max. 1.0 mA |
| Output current | Max. 0.5 A |
| Max. permitted coil energy without external protection elements ²⁾ | 0.37 J |

| | STIO |
|---------------|---|
| Response time | Depending on the logic configuration, for details see: see table 97, page 134 |

- 1) In the event of an error (GND line open circuit) and with a load resistance of at least 2.5 kΩ, no more than the specified leakage current flows on the output. For lower load resistances, the leakage current may be greater; however, the output voltage will be < 5 V in this case. A downstream device, for example a relay or a FPLC (fail-safe programmable logic controller) must detect this state as Low.
- 2) Example of resulting maximum coil induction: 2,960 mH @ 0.5 A.

Mechanical data

Table 155: Mechanical data STIO

| | STIO |
|------------------------|------------------------------|
| Dimensions (W × H × D) | 22.5 mm × 96.5 mm × 120.6 mm |
| Weight | 139 g (± 5%) |

Ambient data

Table 156: Ambient data STIO

| | STIO |
|---|---|
| Enclosure rating (IEC 60529) | IP20 |
| Ambient operating temperature (UL/CSA: surrounding air temperature) | -25 ... +55 °C |
| Storage temperature | -25 ... +70 °C |
| Air humidity | ≤ 95%, non-condensing |
| Operating altitude | Max. 2,000 m above sea level (80 kPa) |
| Vibration resistance | 5–150 Hz / 1 G (EN 60068-2-6) 10–500 Hz / 3 G _{rms} (EN 60068-2-64) |
| Shock resistance, continuous shock | 15 g, 11 ms (EN 60068-2-27) |
| Shock resistance, single shock | 30 g, 11 ms (EN 60068-2-27) |

12.3.6 Analog input module ANAO

Safety-related parameters

The data apply to an ambient temperature of +40 °C.

Table 157: Safety-related parameters ANAO

| | ANAO |
|--|--------------------------|
| Safety integrity level (IEC 61508) Safety integrity level (IEC 62061) | SIL 3 |
| Category (ISO 13849) | Category 4 |
| Performance level (ISO 13849) | PL e |
| PFH _D | 0.166 × 10 ⁻⁹ |
| PFD _{avg} | 2.5 × 10 ⁻⁵ |
| T _M (mission time, ISO 13849) | 20 years |

ANAO general data

Table 158: ANAO general data

| | ANAO |
|------------------------------|------|
| Protection class (IEC 61140) | III |

| | ANAO |
|--------------------------|---|
| Immunity to interference | EN 61000-6-2 |
| Emitted interference | EN 61000-6-4 |
| Connection type | Dual level spring terminals |
| Wire cross-section | Single-wire or fine-stranded wire: 0.2 ... 1.5 mm ² Stranded wire with ferrule: a) With plastic ferrule max. 0.75 mm ² b) Without plastic ferrule max. 1.5 mm ² AWG to UL/CUL: 24 ... 16 |
| Power consumption | Max. 2 W |
| Power loss | |

Interfaces

Table 159: Interfaces ANAO

| | ANAO |
|----------------|-------------------------|
| Data interface | Internal bus (FLEXBUS+) |

Electrical data

Table 160: Analog inputs (AI) ANAO

| | ANAO |
|--|-------------------------------|
| Number of inputs | 2 |
| Type of inputs | Electricity |
| Max. input voltage | 30 V DC |
| Max. current | 30 mA |
| Current measuring range | 4.0 ... 20.0 mA |
| Sampling repetition time | 4.0 ms ¹⁾ |
| Input area min. | 3.5 mA ²⁾ |
| Input area max. | 20.5 mA ³⁾ |
| Measuring resistor R _{SHUNT} | |
| Between 1+ and 1- | 50 Ω |
| Between 2+ and 2- | 50 Ω |
| Measurement accuracy | 1% of the scale value (20 mA) |
| Insulation voltage between AI1 and AI2 | 0.5 kV |
| Transmission frequency | 10.6 kHz |
| Digital resolution | 16 bit |
| Value of the lowest bit | 0.4 μA |

- ¹⁾ Update rate visible at the output (module cycle time); shorter signal pulses at the inputs may not be detected. A maximum of 32 samples per cycle are evaluated.
- ²⁾ Threshold below which a sensor fault is assumed. A max. deviation of 1% (full scale value) gives a tolerance zone of 3.3 mA to 3.7 mA.
- ³⁾ Threshold above which a sensor fault is assumed. A max. deviation of 1% (full scale value) gives a tolerance zone of 20.3 mA to 20.7 mA.



NOTICE

Exceeding the limit values at the inputs

The device may be damaged if this is not observed.

- ▶ Observe the limit values for the inputs (30 V DC / 30 mA).
- ▶ Only use suitable sensors.

Mechanical data

Table 161: Mechanical data ANAO

| | ANAO |
|------------------------|------------------------|
| Dimensions (W × H × D) | 22.5 × 96.5 × 120.6 mm |
| Weight | 117 g (± 5%) |

Ambient data

Table 162: Ambient data ANAO

| | ANAO |
|---|---------------------------------------|
| Enclosure rating (IEC 60529) | IP20 |
| Ambient operating temperature (UL/CSA: surrounding air temperature) | -25 ... +55 °C |
| Storage temperature | -25 ... +70 °C |
| Air humidity | ≤ 95%, non-condensing |
| Operating altitude | Max. 2,000 m above sea level (80 kPa) |
| Vibration resistance | 5–150 Hz / 1 G (EN 60068-2-6) |
| Shock resistance, single shock | 15 g, 11 ms (EN 60068-2-27) |

12.3.7 Motion Control MOCO

Safety-related parameters

The data apply to an ambient temperature of +40 °C.

Table 163: Safety-related parameters MOCO

| | MOCO |
|---|--|
| Safety-related parameters for axes with two encoders (any combination of sine-cosine, TTL, HTL 24 V, HTL 12 V, RS-422, SSI, same or different types) | |
| Safety integrity level (IEC 61508) Safety integrity level (IEC 62061) | SIL 3 |
| Category (ISO 13849) | Category 4 |
| Performance level (ISO 13849) | PL e |
| PFH _D | 5 × 10 ⁻⁹ |
| PFD _{avg} | 1.5 × 10 ⁻⁴ |
| Minimum movement for error detection | ≥ Selected tolerance limit of the function block used for the cross-comparison; e.g., speed comparison, at least 1 × within 24 h |
| Safety-related parameters for axes with one sine-cosine encoder and sine-cosine analog voltage monitoring activated | |
| Safety integrity level (IEC 61508) Safety integrity level (IEC 62061) | SIL 2 |
| Category (ISO 13849) | Category 3 |
| Performance level (ISO 13849) | PL d |

| MOCO | |
|---|--|
| PFH _D | 6 × 10 ⁻⁹ |
| PFD _{avg} | 4 × 10 ⁻⁴ |
| Minimum movement for error detection | ≥ 1 sine-cosine period, at least 1 × within 24 h |
| Supplementary troubleshooting measures | |
| For encoders with Sin/Sin_Ref and Cos/Cos_Ref | Required, see the “Limits of sine-cosine analog voltage monitoring” section of the “Flexi Soft in the Flexi Soft Designer Configuration Software” operating instructions |
| For encoders with Sin+/Sin- and Cos+/Cos- | Not required |
| General safety technology parameters | |
| T _M (mission time, ISO 13849) | 20 years |

- 1) Typically, in accordance with generally accepted test principles set out by testing authorities, the requirement here is that provision must be made in the application to ensure that the unit to be monitored executes a movement at least once within 24 hours. This movement must trigger a signal change at the encoder system on the basis of which the errors to be considered are detected.
- 2) Sin_Ref and Cos_Ref are DC voltage, typically 2.5 V DC.
- 3) E.g., joint use of the encoder signals for the electronic switching of the drive system.
- 4) Sin- and Cos- are the inverted voltage of Sin+ and Cos+ respectively.

General data

Table 164: MOCO general data

| MOCO | |
|------------------------------|------------------------------------|
| Protection class (IEC 61140) | III |
| Immunity to interference | EN 61000-6-2 |
| Emitted interference | EN 61000-6-4 |
| Connection type | Micro-D-Sub male connector, 15-pin |
| Power consumption | Max. 2.5 W |
| Power loss | |

Interfaces

Table 165: Interfaces MOCO

| MOCO | |
|----------------|-------------------------|
| Data interface | Internal bus (FLEXBUS+) |

Electrical data

Table 166: Encoder connection at MOCO

| | Minimum | Typical | Maximum |
|---|---------|---------|---------|
| General values (ENCx_A+, ENCx_B+, ENCx_C+, ENCx_A-, ENCx_B-, ENCx_C-, ENC_OV) | | | |
| Input resistance in the case of configuration for SSI encoders or A/B incremental encoders ¹ | 35 kΩ | - | - |
| Input resistance in the case of configuration for sine-cosine encoders ² | 0.9 kΩ | 1 kΩ | 1.1 kΩ |
| Differential resistance in the case of configuration for SSI encoders or RS-422 A/B incremental encoders ³ | 100 Ω | 120 Ω | 150 Ω |
| Encoder power supply (ENC1_24V, ENC2_24V, ENC_OV) | | | |

| | Minimum | Typical | Maximum |
|--|---------|---------|-------------------|
| Voltage drop Output voltage ⁴ | - | - | 1.8 V |
| Output current ENC1_24V | - | - | 0.2 A sum current |
| Output current ENC2_24V | - | - | |
| Current limitation ENC1_24V | - | 0.7 A | < 1 s: 1.2 A |
| Current limitation ENC2_24V | - | | ≥ 1 s: 1.0 A |
| TTL, 2 outputs (ENCx_A+, ENCx_A-, ENCx_B+, ENCx_B-) | | | |
| Input voltage difference High ⁶ | 2 V | 5 V | 5.3 V |
| Input voltage difference Low ⁶ | -0.3 V | 0 V | 0.8 V |
| Input voltage ⁷ | -5 V | - | 10 V |
| TTL, 2 output pairs (ENCx_A+, ENCx_A-, ENCx_B+, ENCx_B-, ENC_0V) | | | |
| Input voltage difference High ⁶ | 1.2 V | 5 V | 5.6 V |
| Input voltage difference Low ⁶ | -5.6 V | -5 V | -1.2 V |
| Input voltage ⁷ | -5 V | - | 10 V |
| HTL 24 V, 2 outputs (ENCx_A+, ENCx_A-, ENCx_B+, ENCx_B-) | | | |
| Input voltage difference High ⁶ | 13 V | 24 V | 30 V |
| Input voltage difference Low ⁶ | -3 V | 0 V | 5 V |
| Input voltage ⁷ | -10 V | - | 40 V |
| HTL 24 V, 2 output pairs (ENCx_A+, ENCx_A-, ENCx_B+, ENCx_B-, ENC_0V) | | | |
| Input voltage difference High ⁶ | 8 V | 24 V | 30 V |
| Input voltage difference Low ⁶ | -30 V | -24 V | -8 V |
| Input voltage ⁷ | -10 V | - | 40 V |
| HTL 12 V, 2 outputs (ENCx_A+, ENCx_A-, ENCx_B+, ENCx_B-) | | | |
| Input voltage difference High ⁶ | 6.5 V | 12 V | 15 V |
| Input voltage difference Low ⁶ | -1 V | 0 V | 2.5 V |
| Input voltage ⁷ | -5 V | - | 20 V |
| HTL 12 V, 2 pairs of outputs (ENCx_A+, ENCx_A-, ENCx_B+, ENCx_B-, ENC_0V) | | | |
| Input voltage difference High ⁶ | 4 V | 12 V | 15 V |
| Input voltage difference Low ⁶ | -15 V | -12 V | -4 V |
| Input voltage ⁷ | -5 V | - | 20 V |
| SSI encoders (ENCx_A+, ENCx_A-, ENCx_C+, ENCx_C-, ENC_0V) | | | |
| Input voltage difference High for Clock, if SSI listener, and Data ⁶ | 0.2 V | - | 5 V |
| Input voltage difference Low for Clock, if SSI listener, and Data ⁶ | -5 V | - | -0.2 V |
| Input voltage ⁷ | -7 V | - | 7 V |
| Output voltage difference High for Clock, if SSI master ⁸ | 2 V | - | - |
| Output voltage difference Low for Clock, if SSI master ⁸ | - | - | -2 V |
| A/B incremental encoder with HTL 24 V, HTL 12 V, TTL (ENCx_A+, ENCx_A-, ENCx_B+, ENCx_B-, ENC_0V) | | | |
| Input frequency | - | - | 300 kHz |
| Pulse duration High | 1.5 μs | - | - |
| Pulse duration Low | 1.5 μs | - | - |

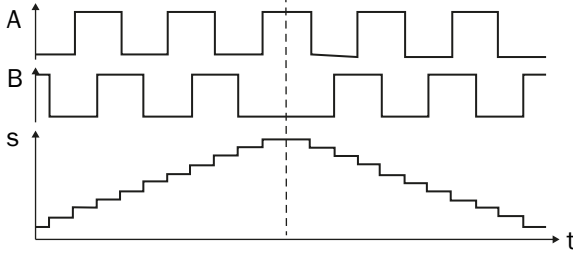
| | Minimum | Typical | Maximum |
|--|--|----------------------|---------------------|
| Edge distance A/B (phase shift) | 70° | 90° | 110° |
| Accuracy error affecting speed detection ⁹ | Max. 5% incl. the internal resolution of the speed information | | |
| Accuracy error affecting position detection ¹⁰ | Max. 1 increment of the internal resolution of the position information | | |
| Counting direction |  <p>S = position information</p> | | |
| A/B incremental encoder with RS-422 (ENC1_A+, ENC1_A-, ENC1_C+, ENC1_C-, ENC_OV) | | | |
| Input voltage difference High ⁶ | 0.2 V | - | 5 V |
| Input voltage difference Low ⁶ | -5 V | - | -0.2 V |
| Input voltage ⁷ | -7 V | - | 7 V |
| Output voltage difference High ⁸ | 2 V | - | - |
| Output voltage difference Low ⁸ | - | - | -2 V |
| Input frequency | - | - | 1 MHz |
| Pulse duration High | 0.4 μs | - | - |
| Pulse duration Low | 0.4 μs | - | - |
| Edge distance A/B (phase shift) | 70° | 90° | 110° |
| Accuracy error affecting speed detection ⁹ | Max. 5% incl. the internal resolution of the speed information | | |
| Accuracy error affecting position detection ¹⁰ | Max. 1 increment of the internal resolution of the position information | | |
| Sine-cosine encoder (ENCx_A+, ENCx_A-, ENCx_B+, ENCx_B-, ENC_OV) | | | |
| Input voltage difference ¹⁷ | 0.8 V _{pp} | 1 V _{pp} | 1.2 V _{pp} |
| Input voltage ¹⁸ | 0 V | - | 5 V |
| Input frequency | 0 Hz | - | 120 kHz |
| Phase shift | 80° | 90° | 100° |
| Sine-cosine analog voltage monitoring ¹⁹ , lower limit for vector length monitoring ¹⁷ | 0.5 V _{pp} | 0.55 V _{pp} | - |
| Sine-cosine analog voltage monitoring ¹⁹ , upper limit for vector length monitoring ¹⁷ | - | 1.26 V _{pp} | 1.5 V _{pp} |
| Accuracy error affecting speed detection ²⁰ | Max. 5% incl. the internal resolution of the speed information | | |
| Accuracy error affecting position detection ²¹ | Max. 1 increment of the internal resolution of the position information | | |

| | Minimum | Typical | Maximum |
|---|--|---------|---------|
| Counting direction | <p>S = position information</p> | | |
| SSI encoder (ENCx_A+, ENCx_A-, ENCx_C+, ENCx_C-, ENC_OV) | | | |
| Baud rate ^{11 14} | 100 kHz | - | 1 MHz |
| Clock gap between data packages (mono flop time) ¹² | 100 μs | - | - |
| Synchronization SSI Clock for SSI master between encoder 1 and encoder 2 | -1 ms | - | 1 ms |
| “Max. data reception interval” parameter tolerance ¹⁴ | -0.5 ms | - | 0.5 ms |
| Number of position data bits ^{14 13 22} | 8 | - | 32 |
| Number of bits of the complete SSI protocol frame ^{14 13 23} | 8 | - | 62 |
| Changing the position information (speed) per max. data reception interval ^{14 24} | | | |
| ≤ 16 position data bits ¹⁴ | Max. ½ value range of position data bits – 1 increment | | |
| ≥ 17 position data bits ¹⁴ | Max. 65,535 increments | | |
| Accuracy error affecting speed detection ¹⁵ | Max. 5% incl. the internal resolution of the speed information | | |
| Accuracy error affecting position detection ¹⁶ | Max. 1 increment of the internal resolution of the position information | | |
| | WARNING | | |
| | <p>Incorrect data is output if the maximum speed is exceeded</p> <p>The dangerous state may not be stopped or not be stopped in a timely manner in the event of non-compliance.</p> <p>The target safety-related level may not be achieved in the event of non-compliance.</p> <ul style="list-style-type: none"> ▶ Observe maximum speed. ▶ Only use suitable encoders for the application. | | |

- 1 Resistance between ENCx_y+/- and ENC_OV.
- 2 Resistance between ENCx_y+/- and ENC_OV. An input voltage of 30 V between ENCx_y+/- and ENC_OV will not damage the module, e.g., in the event of voltage limiting, if the voltage exceeds 5 V.
- 3 Resistance between ENCx_y+ and ENCx_y- with series capacitor to block direct current load. An input voltage of 30 V will not damage the module.
- 4 Voltage between A1 of the main module and ENCx_24V at 0.2 A sum load current.
- 6 Voltage between ENCx_y+ and ENCx_y-.
- 7 Voltage between ENCx_y+ and ENC_OV as well as between ENCx_y- and ENC_OV.
- 8 Voltage between ENCx_y+ and ENCx_y- with a terminator of ≥ 60 Ω.
- 9 Plus the resolution of the speed information based on the resolution of the encoder system:
 - a) Rotational movement in rpm = 15,000/(4 × number of A/B periods per revolution)
 - b) Linear movement in mm/s = 250/(4 × number of A/B periods per revolution)
- 10 Plus the resolution of the position information based on the resolution of the encoder system: 1 rev./ (4 × number of A/B periods per revolution).
- 11 Master and listener mode.
- 12 Time between the falling edges of the clock.
- 13 Without start bit. If repeat transmission is used (clock continues without clock gap so that the same data can be transmitted again), the entire stream is viewed as a frame.

- 14 These are parameters of the SSI encoder that can be set in Flexi Soft Designer.
- 15 Plus the resolution of the speed information based on the resolution of the encoder system:
 - a) Rotational movement in rpm = 15,000/(increments per revolution)
 - b) Linear movement in mm/s = 250/(increments per revolution)
- 16 Plus the resolution of the position information based on the resolution of the encoder system: 1 rev./(increments per revolution).
- 17 Peak-to-peak voltage between ENC_x_y+ and ENC_x_y-.
- 18 Voltage between ENC_x_y+ and ENC_OV as well as between ENC_x_y- and ENC_OV.
- 19 For a description of this function, refer to the “Sine-cosine analog voltage monitoring” section in the “Flexi Soft in the Flexi Soft Designer Configuration Software” operating instructions.
- 20 Plus the resolution of the speed information based on the resolution of the encoder system:
 - a) Rotational movement in rpm = 15,000/(4 x number of sine-cosine periods per revolution)
 - b) Linear movement in mm/s = 250/(4 x number of sine-cosine periods per revolution)
- 21 Plus the resolution of the position information based on the resolution of the encoder system: 1 rev./(4 x number of sine-cosine periods per revolution).
- 22 Firmware version ≥ V1.10.0. With earlier firmware versions 16 ... 32 bits.
- 23 Firmware version ≥ V1.10.0. With earlier firmware versions 16 ... 62 bits.
- 24 If the maximum permissible change to the position information (speed) is exceeded, then this can lead to the output of an inverted rotation direction and to a lower speed, since it results in non-recognized overflowing of the position data bits.

Mechanical data

Table 167: Mechanical data MOCO

| | MOCO |
|------------------------|------------------------|
| Dimensions (W × H × D) | 22.5 × 96.5 × 126.2 mm |
| Weight | 120 g |

Ambient data

Table 168: Ambient data MOCO

| | MOCO |
|---|---|
| Enclosure rating (IEC 60529) | IP20 |
| Ambient operating temperature (UL/CSA: surrounding air temperature) | -25 ... +55 °C |
| Storage temperature | -25 ... +70 °C |
| Air humidity | ≤ 95%, non-condensing |
| Operating altitude | Max. 2,000 m above sea level (80 kPa) |
| Vibration resistance | 5–150 Hz / 1 G (EN 60068-2-6) 10–500 Hz / 3 G _{rms} (EN 60068-2-64) |
| Shock resistance, continuous shock | 15 g, 11 ms (EN 60068-2-27) |
| Shock resistance, single shock | 30 g, 11 ms (EN 60068-2-27) |

12.3.8 Motion Control MOC1

Safety-related parameters

The data apply to an ambient temperature of +40 °C.

Table 169: Safety-related parameters MOCO

| | MOC1 |
|---|------------|
| Safety-related parameters for axes with two encoders (any combination of sine-cosine, TTL, HTL 24 V, HTL 12 V, RS-422, SSI, same or different types) | |
| Safety integrity level (IEC 61508) Safety integrity level (IEC 62061) | SIL 3 |
| Category (ISO 13849) | Category 4 |
| Performance level (ISO 13849) | PL e |

| | MOC1 |
|--|---|
| PFH _D | 5 × 10 ⁻⁹ |
| PFD _{avg} | 1.5 × 10 ⁻⁴ |
| Minimum movement for error detection | ≥ Selected tolerance limit of the function block used for the cross-comparison; e.g., position comparison, at least 1 × within 24 h |
| Safety-related parameters for axes with one sine-cosine encoder and sine-cosine analog voltage monitoring activated | |
| Safety integrity level (IEC 61508) Safety integrity level (IEC 62061) | SIL 2 |
| Category (ISO 13849) | Category 3 |
| Performance level (ISO 13849) | PL d |
| PFH _D | 6 × 10 ⁻⁹ |
| PFD _{avg} | 4 × 10 ⁻⁴ |
| Minimum movement for error detection | ≥ 1 sine-cosine period, at least 1 × within 24 h |
| Supplementary error control measures | |
| For encoders with Sin/Sin_Ref and Cos/Cos_Ref | Required, see section “Limits of sine-cosine analog voltage monitoring” in the “Flexi Soft in the Flexi Soft Designer Configuration Software” and “Flexi Soft in the Safety Designer Configuration Software” operating instructions ¹⁾ |
| For encoders with Sin+/Sin- and Cos+/Cos- | Not required |
| General safety-related parameters | |
| T _M (mission time, ISO 13849) | 20 years |

- 1) In accordance with generally recognized testing principles, test authorities typically stipulate that the application must ensure the monitored unit performs a movement at least once within the space of 24 hours. This movement must generate a signal change on the encoder system, which can be used as a basis for detecting the relevant errors.
- 1) E.g., shared use of encoder signals for electronic commutation of the drive system.
- 2) Sin_Ref and Cos_Ref are DC voltages, typically 2.5 V DC.
- 4) Sin- and Cos- are the inverted voltages of Sin+ and Cos+ respectively.

General data

Table 170: MOC1 general data

| | MOC1 |
|------------------------------|------------------------------------|
| Protection class (IEC 61140) | III |
| Immunity to interference | EN 61000-6-2 |
| Emitted interference | EN 61000-6-4 |
| Connection type | Micro D-Sub male connector, 15-pin |
| Power consumption | Max. 2.5 W |
| Power loss | |

Interfaces

Table 171: Interfaces MOC1



| | MOC1 |
|----------------|-------------------------|
| Data interface | Internal bus (FLEXBUS+) |

Electrical data

Table 172: Encoder connection at MOC1

| | Minimum | Typical | Maximum |
|--|---------|---------|-------------------|
| General values (ENCx_A+, ENCx_B+, ENCx_C+, ENCx_A-, ENCx_B-, ENCx_C-, ENC_0V) | | | |
| Input resistance in the case of configuration for SSI encoders or A/B incremental encoders ¹⁾ | 35 kΩ | - | - |
| Input resistance in the case of configuration for sine-cosine encoders ²⁾ | 0.9 kΩ | 1 kΩ | 1.1 kΩ |
| Differential resistance in the case of configuration for SSI encoders or RS-422 A/B incremental encoders ³⁾ | 100 Ω | 120 Ω | 150 Ω |
| Encoder voltage supply (ENC1_24V, ENC2_24V, ENC_0V) | | | |
| Voltage drop Output voltage ⁴⁾ | - | - | 1.8 V |
| Output current ENC1_24V | - | - | 0.2 A sum current |
| Output current ENC2_24V | - | - | |
| Current limitation ENC1_24V | - | 0.7 A | < 1 s: 1.2 A |
| Current limitation ENC2_24V | | | ≥ 1 s: 1.0 A |
| TTL, 2 outputs (ENCx_A+, ENCx_A-, ENCx_B+, ENCx_B-) | | | |
| Input voltage difference High ⁵⁾ | 2 V | 5 V | 5.3 V |
| Input voltage difference Low ⁵⁾ | -0.3 V | 0 V | 0.8 V |
| Input voltage ⁶⁾ | -5 V | - | 10 V |
| TTL, 2 pairs of outputs (ENCx_A+, ENCx_A-, ENCx_B+, ENCx_B-, ENC_0V) | | | |
| Input voltage difference High ⁵⁾ | 1.2 V | 5 V | 5.6 V |
| Input voltage difference Low ⁵⁾ | -5.6 V | -5 V | -1.2 V |
| Input voltage ⁶⁾ | -5 V | - | 10 V |
| HTL 24 V, 2 outputs (ENCx_A+, ENCx_A-, ENCx_B+, ENCx_B-) | | | |
| Input voltage difference High ⁵⁾ | 13 V | 24 V | 30 V |
| Input voltage difference Low ⁵⁾ | -3 V | 0 V | 5 V |
| Input voltage ⁶⁾ | -10 V | - | 40 V |
| HTL 24 V, 2 pairs of outputs (ENCx_A+, ENCx_A-, ENCx_B+, ENCx_B-, ENC_0V) | | | |
| Input voltage difference High ⁵⁾ | 8 V | 24 V | 30 V |
| Input voltage difference Low ⁵⁾ | -30 V | -24 V | -8 V |
| Input voltage ⁶⁾ | -10 V | - | 40 V |
| HTL 12 V, 2 outputs (ENCx_A+, ENCx_A-, ENCx_B+, ENCx_B-) | | | |
| Input voltage difference High ⁵⁾ | 6.5 V | 12 V | 15 V |
| Input voltage difference Low ⁵⁾ | -1 V | 0 V | 2.5 V |
| Input voltage ⁶⁾ | -5 V | - | 20 V |
| HTL 12 V, 2 pairs of outputs (ENCx_A+, ENCx_A-, ENCx_B+, ENCx_B-, ENC_0V) | | | |
| Input voltage difference High ⁵⁾ | 4 V | 12 V | 15 V |
| Input voltage difference Low ⁵⁾ | -15 V | -12 V | -4 V |
| Input voltage ⁶⁾ | -5 V | - | 20 V |
| SSI encoder (ENCx_A+, ENCx_A-, ENCx_C+, ENCx_C-, ENC_0V) | | | |
| Input voltage difference High for Clock, if SSI listener, and Data ⁵⁾ | 0.2 V | - | 5 V |

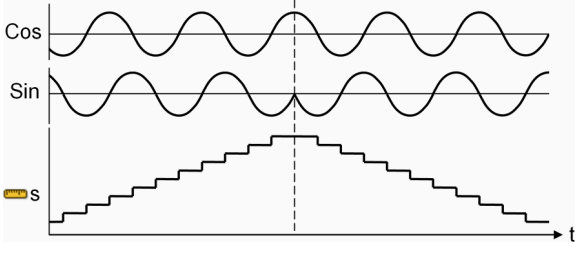
| | Minimum | Typical | Maximum |
|--|---|-------------------|---------------------|
| Input voltage difference Low for Clock, if SSI listener, and Data ⁵⁾ | -5 V | - | -0.2 V |
| Input voltage ⁶⁾ | -7 V | - | 7 V |
| Output voltage difference High for Clock, if SSI master ⁷⁾ | 2 V | - | - |
| Output voltage difference Low for Clock, if SSI master ⁷⁾ | - | - | -2 V |
| A/B incremental encoder with HTL 24 V, HTL 12 V, TTL (ENCx_A+, ENCx_A-, ENCx_B+, ENCx_B-, ENC_OV) | | | |
| Input frequency | - | - | 300 kHz |
| Pulse duration High | 1.5 µs | - | - |
| Pulse duration Low | 1.5 µs | - | - |
| Edge distance A/B (phase shift) | 70° | 90° | 110° |
| Accuracy error affecting speed detection ⁸⁾ | Max. 5% incl. the internal resolution of the speed information | | |
| Accuracy error affecting position detection ⁹⁾ | Max. 1 increment of the internal resolution of the position information | | |
| Counting direction | <p>S = position information</p> | | |
| A/B incremental encoder with RS-422 (ENC1_A+, ENC1_A-, ENC1_C+, ENC1_C-, ENC_OV) | | | |
| Input voltage difference High ⁵⁾ | 0.2 V | - | 5 V |
| Input voltage difference Low ⁵⁾ | -5 V | - | -0.2 V |
| Input voltage ⁶⁾ | -7 V | - | 7 V |
| Output voltage difference High ⁷⁾ | 2 V | - | - |
| Output voltage difference Low ⁷⁾ | - | - | -2 V |
| Input frequency | - | - | 1 MHz |
| Pulse duration High | 0.4 µs | - | - |
| Pulse duration Low | 0.4 µs | - | - |
| Edge distance A/B (phase shift) | 70° | 90° | 110° |
| Accuracy error affecting speed detection ⁸⁾ | Max. 5% incl. the internal resolution of the speed information | | |
| Accuracy error affecting position detection ⁹⁾ | Max. 1 increment of the internal resolution of the position information | | |
| Sine-cosine encoder (ENCx_A+, ENCx_A-, ENCx_B+, ENCx_B-, ENC_OV) | | | |
| Input voltage difference ¹⁰⁾ | 0.8 V _{PP} | 1 V _{PP} | 1.2 V _{PP} |
| Input voltage ¹¹⁾ | 0 V | - | 5 V |
| Input frequency | 0 Hz | - | 120 kHz |
| Phase shift | 80° | 90° | 100° |

| | Minimum | Typical | Maximum |
|--|--|----------------------|---------------------|
| Sine-cosine analog voltage monitoring ¹²⁾ , lower limit for vector length monitoring ¹⁰⁾ | 0.5 V _{PP} | 0.55 V _{PP} | – |
| Sine-cosine analog voltage monitoring ¹²⁾ , upper limit for vector length monitoring ¹⁰⁾ | – | 1.26 V _{PP} | 1.5 V _{PP} |
| Accuracy error affecting speed detection ¹³⁾ | Max. 5% incl. the internal resolution of the speed information | | |
| Accuracy error affecting position detection ¹⁴⁾ | Max. 1 increment of the internal resolution of the position information | | |
| Counting direction |  <p>S = position information</p> | | |
| SSI encoder (ENCx_A+, ENCx_A-, ENCx_C+, ENCx_C-, ENC_OV) | | | |
| Baud rate ¹⁵⁾ ¹⁶⁾ | 100 kHz | – | 1 MHz |
| Clock gap between data packages (mono flop time) ¹⁷⁾ | 100 μs | – | – |
| Synchronization SSI Clock for SSI master between encoder 1 and encoder 2 | –1 ms | – | 1 ms |
| “Max. data reception interval” parameter tolerance ¹⁶⁾ | –0.5 ms | – | 0.5 ms |
| Number of position data bits ¹⁶⁾ ¹⁸⁾ | 8 | – | 32 |
| Number of bits of the complete SSI protocol frame ¹⁶⁾ ¹⁸⁾ | 8 | – | 62 |
| Changing the position information (speed) per max. data reception interval ¹⁶⁾ ¹⁹⁾ | | | |
| ≤ 16 position data bits ¹⁶⁾ | Max. ½ value range of position data bits – 1 increment | | |
| ≥ 17 position data bits ¹⁶⁾ | Max. 65,535 increments | | |
| Accuracy error affecting speed detection ²⁰⁾ | Max. 5% incl. the internal resolution of the speed information | | |
| Accuracy error affecting position detection ²¹⁾ | Max. 1 increment of the internal resolution of the position information | | |
|  | WARNING | | |
| | <p>Incorrect data is output if the maximum speed is exceeded</p> <p>The dangerous state may not be stopped or not be stopped in a timely manner in the event of non-compliance.</p> <p>The target safety-related level may not be achieved in the event of non-compliance.</p> <ul style="list-style-type: none"> ▶ Observe maximum speed. ▶ Only use suitable encoders for the application. | | |

- 1) Resistance between ENCx_y+/- and ENC_OV.
- 2) Resistance between ENCx_y+/- and ENC_OV. An input voltage of 30 V between ENCx_y+/- and ENC_OV will not damage the module; e.g., if the voltage exceeds 5 V in the event of voltage limiting.
- 3) Resistance between ENCx_y+ and ENCx_y- with series capacitor to block direct current load. An input voltage of 30 V will not damage the module.

- 4) Voltage between A1 of the main module and ENCx_24V at 0.2 A sum load current.
- 5) Voltage between ENCx_y+ and ENCx_y-.
- 6) Voltage between ENCx_y+ and ENC_OV and between ENCx_y- and ENC_OV.
- 7) Voltage between ENCx_y+ and ENCx_y- with a terminating resistance of $\geq 60 \Omega$.
- 8) Plus the resolution of the speed information based on the resolution of the encoder system:
 - a) Rotational movement in rpm = $15,000 / (4 \times \text{number of A/B periods per revolution})$
 - b) Linear movement in mm/s = $250 / (4 \times \text{number of A/B periods per revolution})$
- 9) Plus the resolution of the position information based on the resolution of the encoder system: $1 \text{ rev.} / (4 \times \text{number of A/B periods per revolution})$.
- 10) Peak to peak voltage between ENCx_y+ and ENCx_y-.
- 11) Voltage between ENCx_y+ and ENC_OV and between ENCx_y- and ENC_OV.
- 12) You can find a description of this function in the “Flexi Soft in the Flexi Soft Designer Configuration Software” or “Flexi Soft in the Safety Designer Configuration Software” operating instructions in the “Sine-cosine analog voltage monitoring” section.
- 13) Plus the resolution of the speed information based on the resolution of the encoder system:
 - a) Rotational movement in rpm = $15,000 / (4 \times \text{number of sine-cosine periods per revolution})$
 - b) Linear movement in mm/s = $250 / (4 \times \text{number of sine-cosine periods per revolution})$
- 14) Plus the resolution of the position information based on the resolution of the encoder system: $1 \text{ rev.} / (4 \times \text{number of sine-cosine periods per revolution})$.
- 15) Master mode and listener mode.
- 16) These are parameters of the SSI encoder that can be set using the configuration software.
- 17) Time between the falling edges of the clock.
- 18) Without start bit. If repeat transmission is being used (clock continues without gap in order to transmit the same data again), the entire stream is considered as one frame.
- 19) If the maximum permissible change to the position information (speed) is exceeded, then this can lead to the output of an inverted rotation direction and to a lower speed, since it results in non-recognized overflowing of the position data bits.
- 20) Plus the resolution of the speed information based on the resolution of the encoder system:
 - a) Rotational movement in rpm = $15,000 / (\text{increments per revolution})$
 - b) Linear movement in mm/s = $250 / (\text{increments per revolution})$
- 21) Plus the resolution of the position information based on the resolution of the encoder system: $1 \text{ rev.} / (\text{increments per revolution})$.

Mechanical data

Table 173: Mechanical data MOC1

| | MOC1 |
|------------------------|------------------------------|
| Dimensions (W × H × D) | 22.5 mm × 96.5 mm × 126.2 mm |
| Weight | 120 g |

Ambient data

Table 174: Ambient data MOC1

| | MOC1 |
|---|---|
| Enclosure rating (IEC 60529) | IP20 |
| Ambient operating temperature (UL/CSA: surrounding air temperature) | -25 ... +55 °C |
| Storage temperature | -25 ... +70 °C |
| Air humidity | $\leq 95\%$, non-condensing |
| Operating altitude | Max. 2,000 m above sea level (80 kPa) |
| Vibration resistance | 5–150 Hz / 1 G (EN 60068-2-6) 10–500 Hz / 3 G _{rms} (EN 60068-2-64) |
| Shock resistance, continuous shock | 15 g, 11 ms (EN 60068-2-27) |
| Shock resistance, single shock | 30 g, 11 ms (EN 60068-2-27) |

12.3.9 EBX1, EBX3 and EBX4 encoder/motor feedback connection units
General data

Table 175: General data EBX1, EBX3 and EBX4

| | EBX1, EBX3 and EBX4 |
|------------------------------|---|
| Protection class (IEC 61140) | III |
| Immunity to interference | EN 61000-6-2 |
| Emitted interference | EN 61000-6-4 |
| Wire cross-section | Single-wire or fine-stranded wire: 0.2 ... 1.5 mm ² Stranded wire with ferrule: a) With plastic ferrule max. 0.75 mm ² b) Without plastic ferrule max. 1.5 mm ² AWG to UL/CUL: 24 ... 16 |

Mechanical data

Table 176: Mechanical data EBX1, EBX3 and EBX4

| | EBX1, EBX3 and EBX4 |
|------------------------|---|
| Dimensions (W × H × D) | 45 mm × 142.3 mm × 73.1 mm |
| Weight | EBX1: 119 g EBX3: 170 g EBX4: 163 g |

Ambient data

Table 177: Ambient data EBX1, EBX3 and EBX4

| | EBX1, EBX3 and EBX4 |
|--|---|
| Enclosure rating (IEC 60529) | IP20 |
| Ambient operating temperature (UL/CSA: surrounding air temperature) | -25 ... +55 °C |
| Storage temperature | -25 ... +70 °C |
| Air humidity | ≤ 95%, non-condensing |
| Operating altitude | Max. 2,000 m above sea level (80 kPa) |
| Vibration resistance | 5–150 Hz / 1 G (EN 60068-2-6) 10–500 Hz / 3 G _{rms} (EN 60068-2-64) |
| Shock resistance, continuous shock | 15 g, 11 ms (EN 60068-2-27) |
| Shock resistance, single shock | 30 g, 11 ms (EN 60068-2-27) |

Electrical data

Table 178: EBX1: Voltage supply for encoder ENC1_24V and ENC2_24V (from FX3-MOCx)

| | Minimum | Typical | Maximum |
|--|---|---------|---------|
| Supply voltage | 24 V DC (16.8 ... 24 ... 30 V DC) | | |
| Supply voltage for UL/CSA applications | + 24 V DC | | |
| Type of supply voltage | PELV or SELV The supply current for the encoder/motor feedback connection unit must be externally limited to a maximum of 1 A – either by connecting it to the voltage supply at the encoder connection of the FX3-MOCx, by the power supply unit used or by a fuse. | | |
| Encoder voltage supply (ENC1_24V, ENC2_24V, ENC_0V) | | | |

| | Minimum | Typical | Maximum |
|-----------------------------------|---------|---------|----------------------------|
| Output voltage drop ¹⁾ | – | – | 2.5 V |
| Output current ENC1_24V | – | – | 0.19 A sum current |
| Output current ENC2_24V | – | – | |
| Current limitation ENC1_24V | – | 1.4 A | < 1 s: 2.4 A ²⁾ |
| Current limitation ENC2_24V | | | ≥ 1 s: 2.0 A ²⁾ |

- 1) Voltage between A1 of the main module and ENCx_24V at 0.19 A sum load current.
 2) Sum current of ENC1_24V and ENC2_24V and therefore double value.

Table 179: EBX3 and EBX4: On-board voltage supply U_{out} (from FX3-MOCx)

| | Minimum | Typical | Maximum |
|---|---|----------------------|--|
| Supply voltage | 24 V DC (16.8 ... 24 ... 30 V DC) | | |
| Supply voltage for UL/CSA applications | + 24 V DC | | |
| Type of supply voltage | PELV or SELV The supply current for the encoder/motor feedback connection unit must be externally limited to a maximum of 1 A – either by connecting it to the voltage supply at the encoder connection of the FX3-MOCx, by the power supply unit used or by a fuse. | | |
| Output voltage at U_{out} | | | |
| Rotary switch $U_{out} = 0$ | 4.75 V | 5 V | 5.25 V |
| Rotary switch $U_{out} = 1$ | 6.65 V | 7 V | 7.35 V |
| Rotary switch $U_{out} = 2$ | 11.4 V | 12 V | 12.6 V |
| Rotary switch $U_{out} = 3$ | – | 24 V ¹⁾ | – |
| Permissible output current at U_{out} | | | |
| Rotary switch $U_{out} = 0$ | – | 650 mA ²⁾ | 430 mA ^{3) 4)} |
| Rotary switch $U_{out} = 1$ | – | 470 mA ²⁾ | 310 mA ^{3) 4)} |
| Rotary switch $U_{out} = 2$ | – | 270 mA ²⁾ | 180 mA ^{3) 4)} |
| Rotary switch $U_{out} = 3$ | – | 180 mA ²⁾ | 180 mA ^{3) 4)} |
| Current limitation U_{out} | – | 1.4 A | < 1 s: 2.4 A ⁵⁾ ≥ 1 s: 2.0 A ⁵⁾ |

- 1) The supply voltage for the encoder can be up to 2.8 V below the supply voltage at the system plug (terminal A1).
 2) At 24 V on the FX3-MPLx Flexi Soft system plug.
 3) At 16.8 V on the FX3-MPLx Flexi Soft system plug.
 4) Sum current for all encoders that are supplied via this encoder/motor feedback connection unit, i.e. including the encoders that are connected via D4 on FX3-EBX3, e.g. via another FX3-EBX3.
 5) Sum current of ENC1_24V and ENC2_24V and therefore double value.

12.3.10 Relay modules UE410-2RO/UE410-4RO

Safety-related parameters

The data apply to an ambient temperature of +40 °C.

Table 180: UE410-2RO/UE410-4RO safety-related parameters

| | UE410-2RO/UE410-4RO ¹⁾ |
|------------------------------------|-----------------------------------|
| Safety integrity level (IEC 61508) | SIL 3 |
| Safety integrity level (IEC 62061) | |
| Category (ISO 13849) | Category 4 |
| Performance level (ISO 13849) | PL e (EN ISO 13849-1) |

| | UE410-2RO/UE410-4RO ¹⁾ |
|---|--|
| PFH _D at I = 0.75 A, Switching frequency = h ⁻¹ (see table 181, page 169) | 1.2 × 10 ⁻⁹ |
| PFD _{avg} at I = 0,75 A, Switching frequency = h ⁻¹ | 1.2 × 10 ⁻⁵ |
| B _{10D} value | 0.75 A (AC-15)/4,150,000 (see table 181, page 169) |
| Safe failure fraction (SFF) | 99.6% |
| Diagnostic coverage (DC) | 99% |
| T _M (mission time, ISO 13849) | Depending on PFH _D value, ambient temperature, load case and the switching operations (see table 181, page 169) |
| Number of mechanical switching operations | Min. 200,000 |

1) The following measures are required to achieve the safety-related parameters:

- Once a year, check the correct switching function for each safety-relevant output circuit of relay modules, e.g. by switching the machine or system off and on again, monitored by the EDM function.
- Document the thorough check.

Table 181: PFH_D values of UE410-2RO/UE410-4RO

| Utilization category | I [A] | Switching frequency | Switching operations per year | B _{10D} | PFH _D |
|----------------------|-------------|---------------------|-------------------------------|------------------|------------------------------|
| AC-15 | 0.1 | 1 / h | 8760 | 10,000,000 | 5 × 10 ⁻¹⁰ |
| | 0.75 | 1 / h | 8760 | 4,150,000 | 1.2 × 10⁻⁹ |
| | 3 | 1 / h | 8760 | 400,000 | 1.2 × 10 ⁻⁸ |
| | 5 | 1 / h | 8760 | 70,000 | 7.2 × 10 ⁻⁸ |
| DC-13 | 1 | 1 / h | 8760 | 2,000,000 | 2.5 × 10 ⁻⁹ |
| | 3 | 1 / h | 8760 | 450,000 | 1.1 × 10 ⁻⁸ |
| AC-1 | 2 | 1 / h | 8760 | 1,000,000 | 5 × 10 ⁻⁹ |
| | 4 | 1 / h | 8760 | 600,000 | 8.4 × 10 ⁻⁹ |

General data

Table 182: UE410-2RO/UE410-4RO general data

| | UE410-2RO / UE410-4RO |
|---|-----------------------|
| Immunity to interference | EN 61000-6-2 |
| Emitted interference | EN 61000-6-4 |
| Rated impulse withstand voltage (U _{imp}) | 4 kV |
| Overvoltage category | II (EN 61131-2) |
| Degree of contamination | 2 inside, 3 outside |
| Rated voltage | 300 V AC |
| Galvanic separation | |
| Supply circuit-input circuit | No |
| Supply circuit-output circuit | Yes |
| Input circuit-output circuit | Yes |
| Power consumption | UE410-2RO: Max. 1.6 W |
| Power loss | UE410-4RO: Max. 3.2 W |
| Connection type | Terminals |

| UE410-2RO / UE410-4RO | |
|--|---|
| Wire cross-section | Single-wire or fine-stranded wire: 0.2 ... 1.5 mm ² Stranded wire with ferrule: a) With plastic ferrule max. 0.75 mm ² b) Without plastic ferrule max. 1.5 mm ² AWG to UL/CUL: 24 ... 16 |
| Stripping length | Max. 8 mm |
| Tightening torque | Max. 0.6 Nm |
| For UL-508 and CSA applications | |
| UE410-xx3..., UE410-xxx3... | |
| Cross-sectional area | AWG 30-12 (use only 60/75 °C copper wire) |
| Tightening torque | 5-7 lb-in |
| UE410-xx4..., UE410-xxx4... | |
| Cross-sectional area | AWG 30-12 (use only 60/75 °C copper wire) |

Electrical data

Table 183: Input circuit (B1, B2) of the UE410-2RO/UE410-4RO

| | Minimum | Typical | Maximum |
|------------------|---------|---------|---------|
| Input voltage ON | 18 V DC | - | 30 V DC |

Table 184: Output circuit (13-14, 23-24, 33-34, 43-44) of the UE410-2RO/UE410-4RO

| | Minimum | Typical | Maximum |
|--|---|------------------------|----------|
| Number of normally open contacts | | | |
| UE410-2RO | 2 | | |
| UE410-4RO | 4 | | |
| Number of N/C contacts | | | |
| UE410-2RO | 1 | | |
| UE410-4RO | 2 | | |
| AC switching voltage | 5 V AC | 230 V AC ¹⁾ | 253 V AC |
| DC switching voltage | 5 V DC | 230 V DC ¹⁾ | 253 V DC |
| Switching current | 10 mA | - | 6 A |
| Mechanical service life | Min. 10 ×10 ⁶ | | |
| Electrical endurance | see figure 69, page 171 | | |
| Minimum contact load at U _n = 24 V DC | 50 mW | - | - |
| Sum current | - | - | 8 A |
| Response time ²⁾ | - | - | 30 ms |
| Type of output | Volt-free normally open contacts, positively guided | | |
| Contact material | AgSnO ₂ | | |
| Output circuit protection | 6 A gG, per current path | | |
| Utilization category | AC-15: U _e 250 V, I _e 3 A DC-13: U _e 24 V, I _e 3 A | | |

1) [see figure 68, page 171](#) or [see figure 69, page 171](#).

2) Time from low at B1 / B2 to drop out of relay.

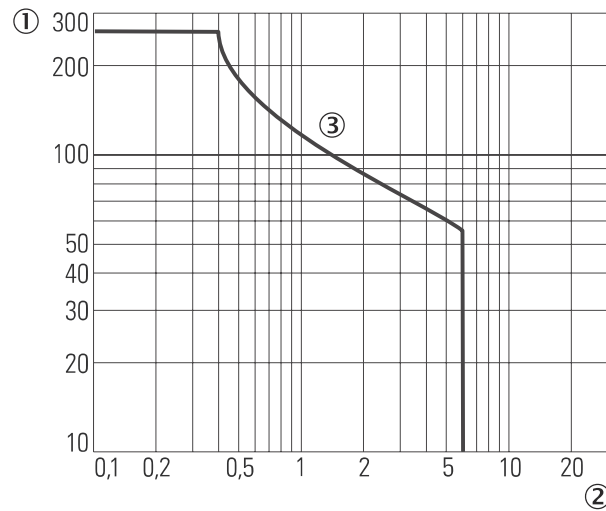

Figure 68: Maximum switching voltage with direct current, relay modules UE410-2RO/UE410-4RO

- ① DC voltage [V DC]
- ② Direct current [A]
- ③ Resistive load

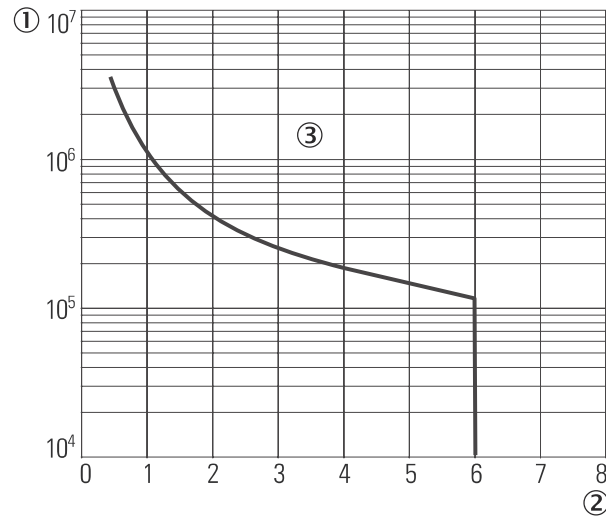

Figure 69: Electrical endurance of relay modules UE410-2RO/UE410-4RO

- ① Switching operations
- ② Switching current [A]
- ③ 250 V AC resistive load with 1 N/O contact

Table 185: Output circuit (Y14, Y24) of the UE410-2RO/UE410-4RO

| | Minimum | Typical | Maximum |
|---|---|-----------|---------|
| Type of output | Normally open contact on internal 24 V DC, positively guided, current limited | | |
| Number of normally open contacts Y14/24 | | | |
| UE410-2RO | 1 | | |
| UE410-4RO | 2 | | |
| Output voltage | 16 V DC | + 24 V DC | 30 V DC |

| | Minimum | Typical | Maximum |
|------------------------------|---------|---------|---------|
| Output current ¹⁾ | - | - | 75 mA |
| Load capacity | - | - | 200 nF |

¹⁾ The total output current is limited. Maximum sum current of all relay modules at Y14 or Y24 is 80 mA.

Mechanical data

Table 186: Mechanical data UE410-2RO/UE410-4RO

| | UE410-2RO/UE410-4RO |
|------------------------|--|
| Dimensions (W × H × D) | 22.5 mm × 96.5 mm × 120.8 mm |
| Weight | UE410-2RO: 160 g (± 5%) UE410-4RO: 186 g (± 5%) |

Ambient data

Table 187: Ambient data UE410-2RO/UE410-4RO

| | UE410-2RO/UE410-4RO |
|---|---|
| Enclosure rating (IEC 60529) | IP20 |
| Ambient operating temperature (UL/CSA: surrounding air temperature) | -25 °C ... +55 °C |
| Storage temperature | -25 °C ... +70 °C |
| Air humidity | ≤ 95%, non-condensing |
| Operating altitude | Max. 2,000 m above sea level (80 kPa) |
| Vibration resistance | 5-150 Hz / 1 G (EN 60068-2-6) 10-500 Hz / 3 G _{rms} (EN 60068-2-64) |
| Shock resistance, continuous shock | 15 g, 11 ms (EN 60068-2-27) |
| Shock resistance, single shock | 30 g, 11 ms (EN 60068-2-27) |

12.3.11 Diode module DM8-A4K

General data

Table 188: General data diode module DM8-A4K

| | Diode module DM8-A4K |
|------------------------------|-----------------------------|
| Stripping length | 7 mm |
| Wire cross-section | 0.2 ... 2.5 mm ² |
| Screw connection | AWG 22-14 |
| Protection class (IEC 61140) | III |
| Contamination rating | 2 |

Electrical data

Table 189: Input data for diode module DM8-A4K

| | Diode module DM8-A4K |
|---------------------------------|----------------------|
| Input voltage (max.) | 25 V AC/60 V DC |
| Reverse voltage | 1,000 V |
| Reverse current | 5 µA |
| Forward voltage | 0.8 V |
| Input current per channel (1/2) | 400 mA |

Mechanical data

Table 190: Mechanical data diode module DM8-A4K

| | Diode module DM8-A4K |
|------------------------|-----------------------|
| Dimensions (W × H × D) | 32 mm × 87 mm × 72 mm |
| Weight | 59 g |

Ambient data

Table 191: Ambient data diode module DM8-A4K

| | Diode module DM8-A4K |
|---|----------------------|
| Ambient operating temperature (UL/CSA: surrounding air temperature) | -25 ... +55 °C |
| Storage temperature | -25 ... +70 °C |
| Enclosure rating | IP00 |

12.4 Dimensional drawings

12.4.1 FX3-CPUx main modules with system plug

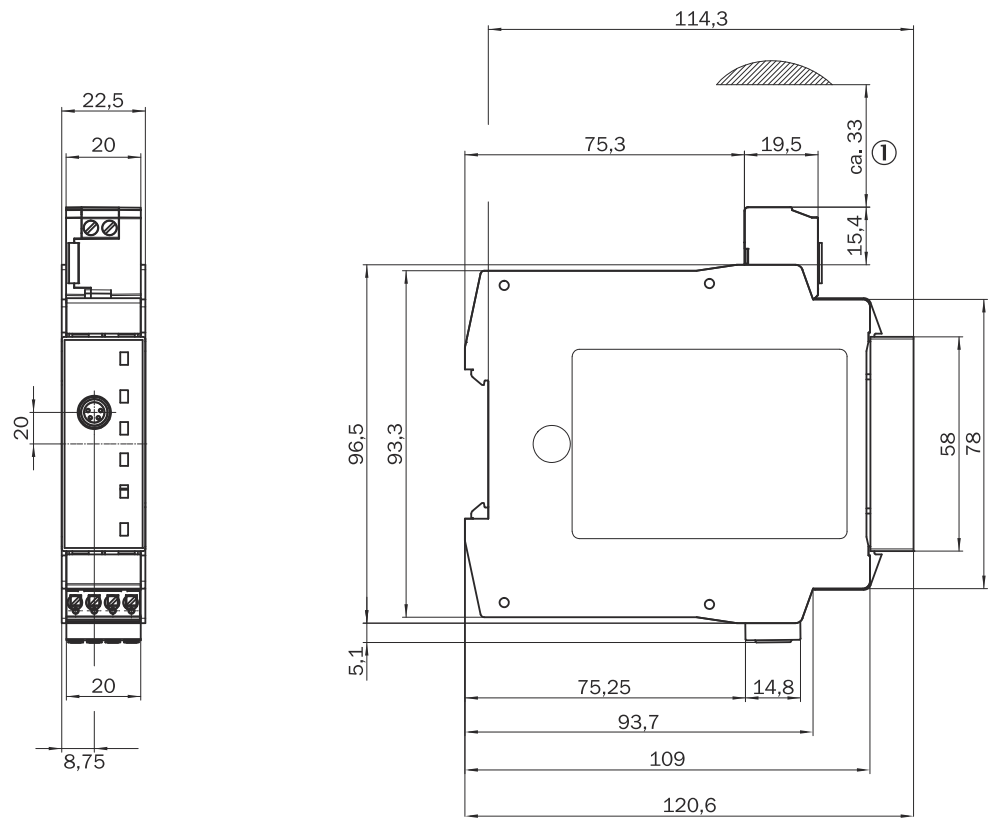

Figure 70: Dimensioned drawing FX3-CPUx (mm)

① Connector range

12.4.2 FX3-XTIO, FX3-XTDI, FX3-XTDS, and FX0-STIO I/O modules, UE410-2RO and UE410-4RO relay modules

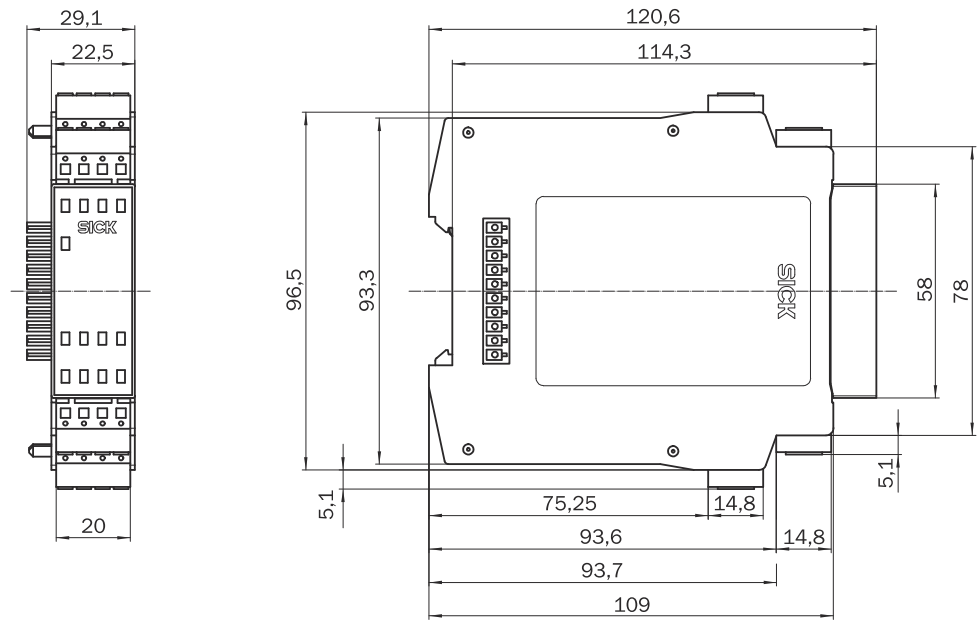

Figure 71: Dimensioned drawing FX3-XTIO, FX3-XTDS, FX0-STIO, FX3-XTDI, UE410-2RO, and UE410-4RO (mm)

12.4.3 FX3-ANA0 analog input module

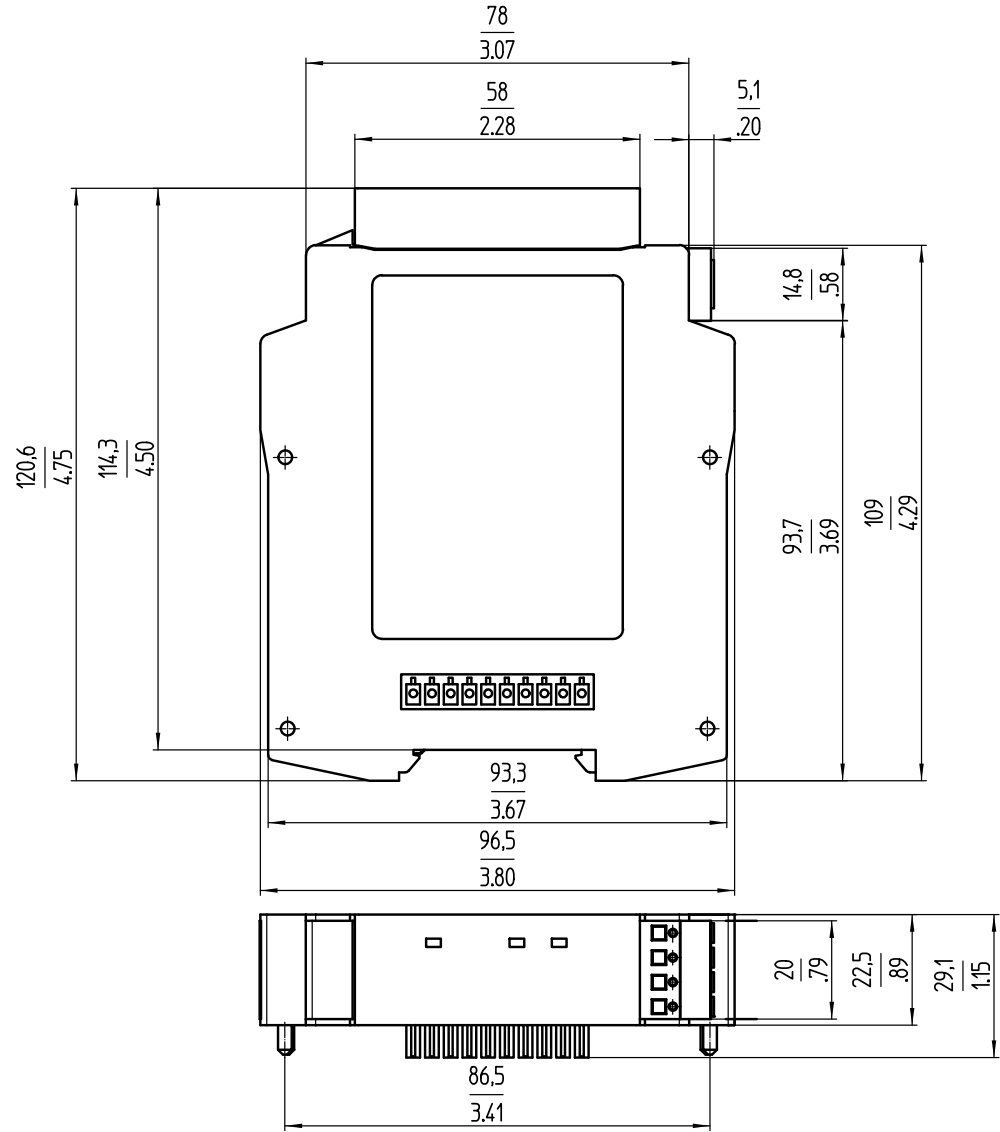

Figure 72: Dimensional drawing for the FX3-ANA0 (mm/in)

12.4.4 FX3-MOCx motion control module

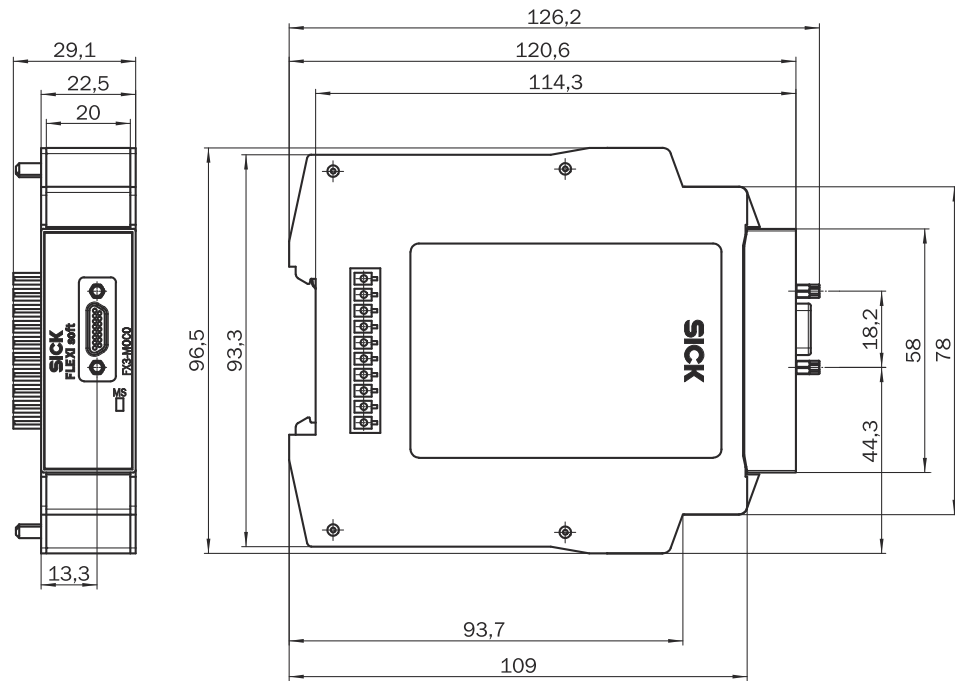

Figure 73: Dimensional drawing for the FX3-MOC0 (mm) ¹⁰⁾

¹⁰⁾ same design as the FX3-MOC1 motion control module.

12.4.5 FX3-EBX1, FX3-EBX3, and FX3-EBX4 encoder/motor feedback connection boxes

FX3-EBX1 optimized dual encoder/motor feedback connection box

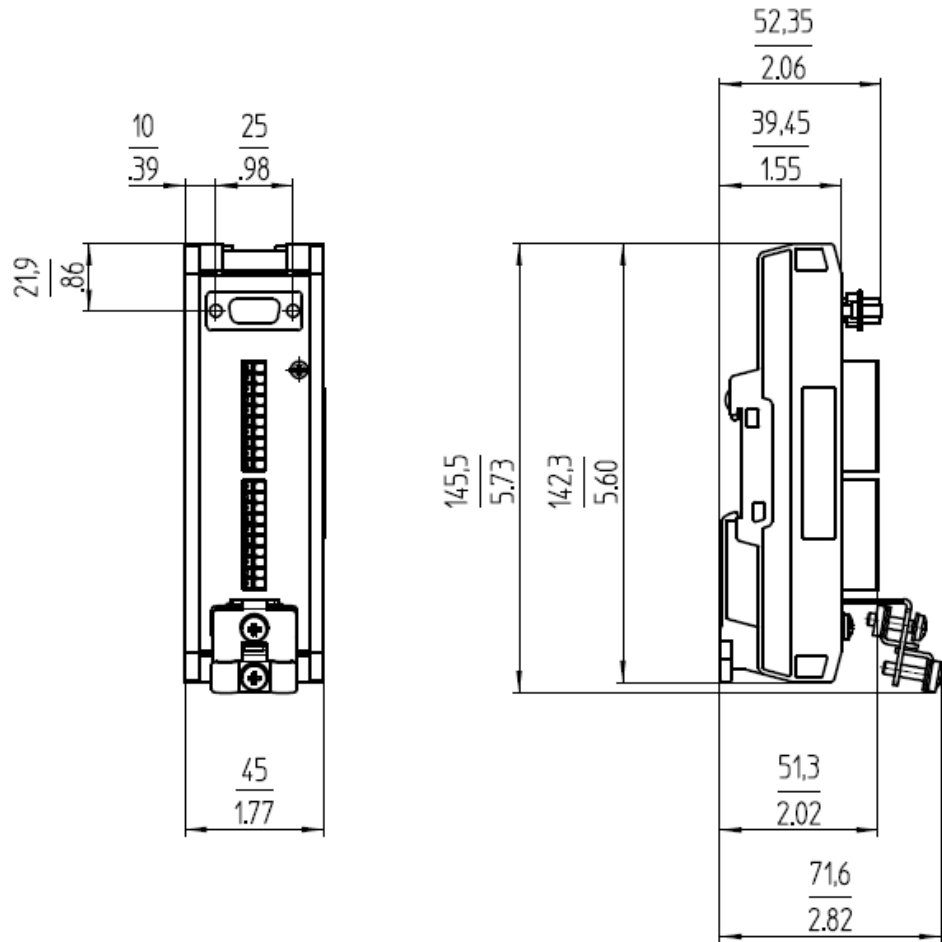

Figure 74: Dimensional drawing for the optimized dual encoder/motor feedback connection box FX3-EBX1 (mm/in)

FX3-EBX3 encoder/motor feedback connection box

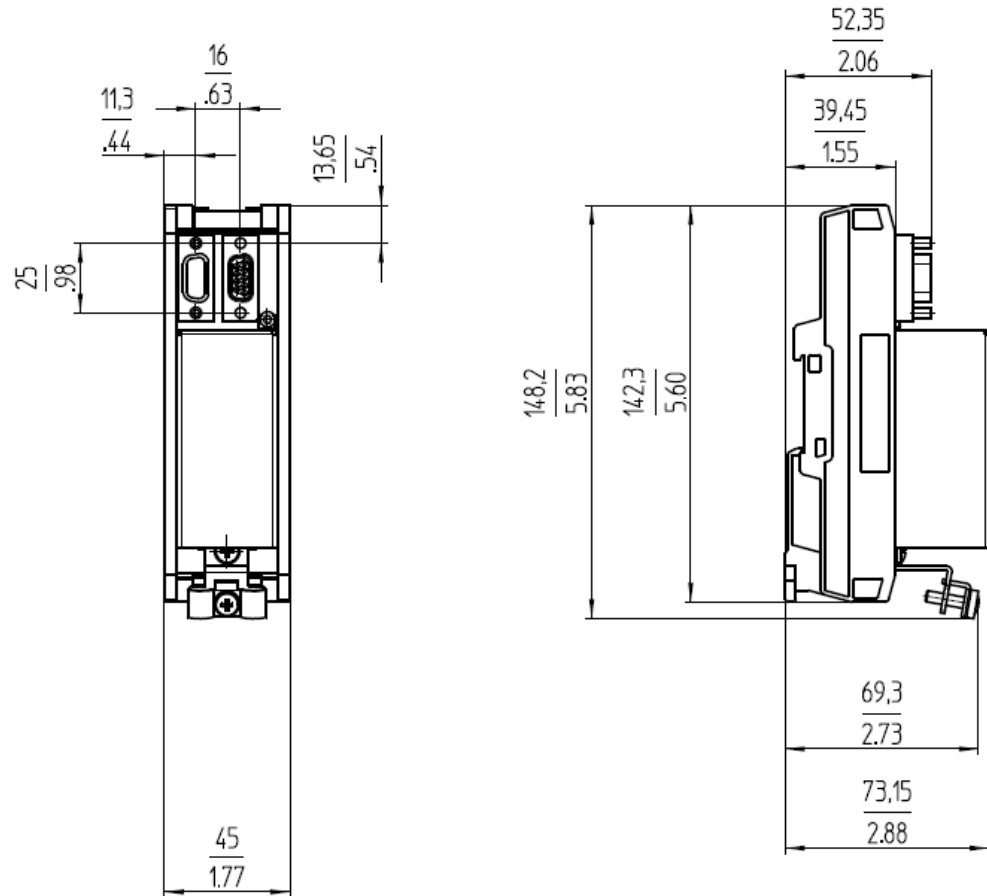

Figure 75: Dimensional drawing for the FX3-EBX3 encoder/motor feedback connection box (mm/in)

FX3-EBX4 dual encoder/motor feedback connection box

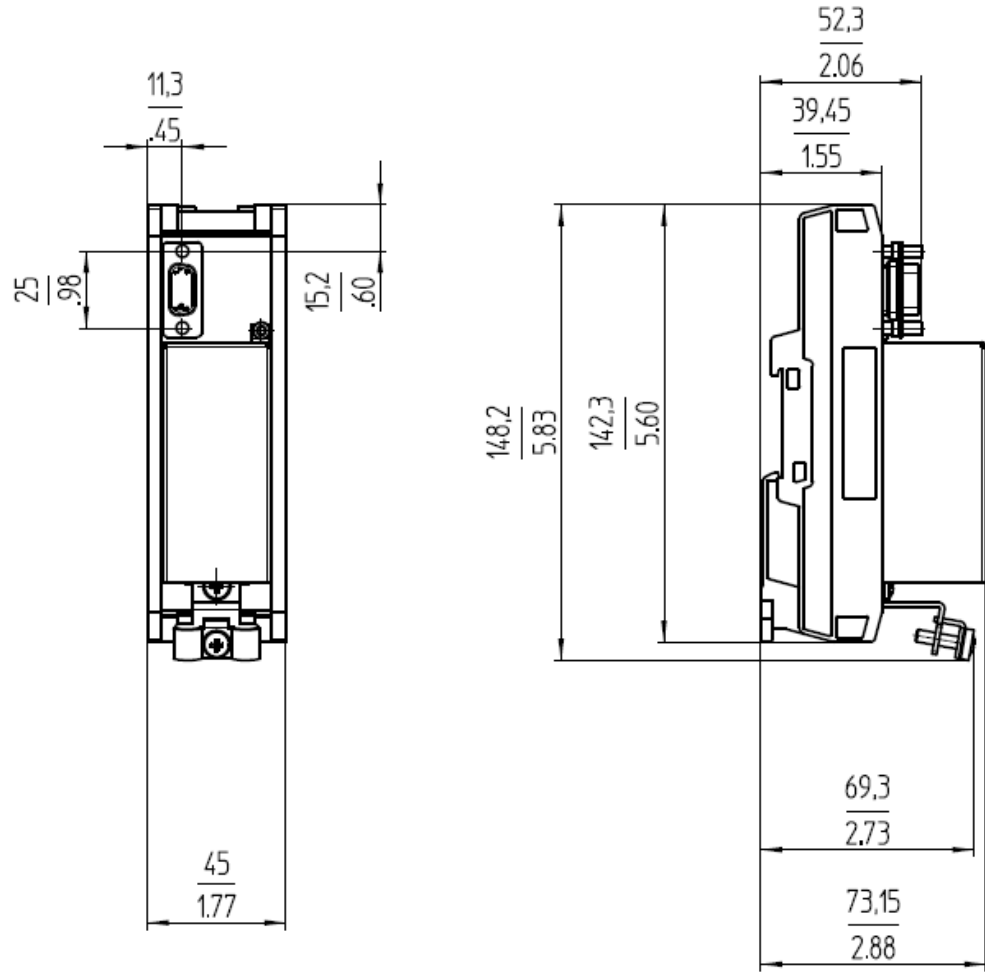

Figure 76: Dimensional drawing for the FX3-EBX4 dual encoder/motor feedback connection box (mm/in)

12.4.6 Diode module DM8-A4K

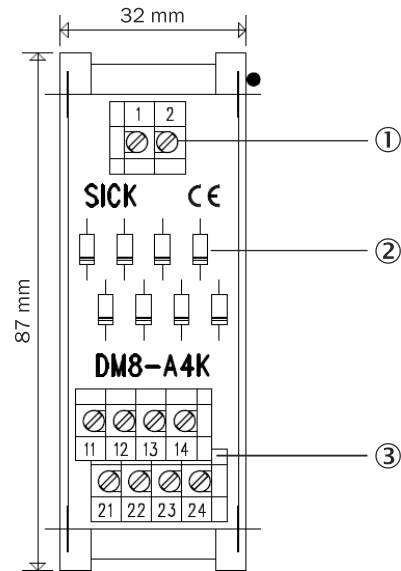

Figure 77: Dimensioned drawing diode module DM8-A4K

- ① Inputs
- ② 8 × 1N4007
- ③ Outputs

13 Ordering information

13.1 System plugs and modules

System plug

Table 192: Ordering information for system plug

| Part | Protective coating ¹⁾ | Type code | Part number |
|---|----------------------------------|---------------|-------------|
| System plug for FX3-CPU0 or FX3-CPU1, screw terminals | No | FX3-MPL000001 | 1043700 |
| | Yes | FX3-MPL000011 | 1050619 |
| System plug for FX3-CPU2 or FX3-CPU3, screw terminals | No | FX3-MPL100001 | 1047162 |
| | Yes | FX3-MPL100011 | 1112303 |

¹⁾ For more challenging ambient conditions (e.g., resistance to sulfur).

Main module

Table 193: Ordering data for main modules

| Part | Protective coating ¹⁾ | Type code | Part number |
|--|----------------------------------|---------------|-------------|
| Main module | No | FX3-CPU000000 | 1043783 |
| | Yes | FX3-CPU000010 | 1050615 |
| Main module 2 EFI connections, plug-in dual level spring terminals | No | FX3-CPU130002 | 1043784 |
| | Yes | FX3-CPU130012 | 1050616 |
| Main module 2 EFI connections, plug-in dual level spring terminals | No | FX3-CPU230002 | 1058999 |
| Main module 2 EFI connections, 1 Flexi-Line connection, plug-in dual level spring terminals | No | FX3-CPU320002 | 1059305 |
| | Yes | FX3-CPU320012 | 1112302 |

¹⁾ For more challenging ambient conditions (e.g., resistance to sulfur).

Gateways

Table 194: Ordering information for gateways

| Part | Protective coating ¹⁾ | Type code | Part number |
|-----------------------------|----------------------------------|---------------|-------------|
| The V3 EtherNet/IP™ gateway | No | FX0-GENT00000 | 1044072 |
| | Yes | FX0-GENT00010 | 1121596 |
| The V2 EtherNet/IP™ gateway | No | FX0-GENT00030 | 1099830 |
| The V3 Modbus® TCP gateway | No | FX0-GMOD00000 | 1044073 |
| | Yes | FX0-GMOD00010 | 1127717 |
| The V2 Modbus® TCP gateway | No | FX0-GMOD00030 | 1130282 |
| The V3 PROFINET IO gateway | No | FX0-GPNT00000 | 1044074 |
| | Yes | FX0-GPNT00010 | 1121597 |
| The V2 PROFINET IO gateway | No | FX0-GPNT00030 | 1099832 |
| EtherCAT gateway | No | FX0-GETC00000 | 1051432 |
| | Yes | FX0-GETC00010 | 1127487 |

| Part | Protective coating ¹⁾ | Type code | Part number |
|---------------------|----------------------------------|----------------|-------------|
| PROFIBUS DP gateway | No | FX0-GPRO00000 | 1044075 |
| | Yes | FX0-GPRO00010 | 1121598 |
| CANopen gateway | No | FX0-GCAN00000 | 1044076 |
| | Yes | FX0-GCAN00010 | 1118379 |
| DeviceNet gateway | No | FX0-GDEV00000 | 1044077 |
| CC-Link gateway | No | FX0-GCC100200 | 1085195 |
| EFI-pro gateway | No | FX3-GEPRO00000 | 1069070 |
| | Yes | FX3-GEPRO00010 | 1112296 |

¹⁾ For more challenging ambient conditions (e.g., resistance to sulfur).

Expansion modules

Table 195: Ordering data for extension modules

| Part | Protective coating ¹⁾ | Type code | Part number |
|--|----------------------------------|---------------|-------------|
| I/O module 8 safety inputs, 4 safety outputs, plug-in dual level spring terminals | No | FX3-XTIO84002 | 1044125 |
| | Yes | FX3-XTIO84012 | 1050618 |
| I/O module 8 safety inputs, plug-in dual level spring terminals | No | FX3-XTDI80002 | 1044124 |
| | Yes | FX3-XTDI80012 | 1050617 |
| I/O module 8 safety inputs, 4 or 6 non-safe outputs, plug-in dual level spring terminals | No | FX3-XTDS84002 | 1061777 |
| | Yes | FX3-XTDS84012 | 1112301 |
| I/O module 6 or 8 non-safe inputs, 8 or 6 non-safe outputs, plug-in dual level spring terminals | No | FX0-STIO68002 | 1061778 |
| | Yes | FX0-STIO68012 | 1112297 |
| Motion Control For connecting two encoders | No | FX3-MOC000000 | 1062344 |
| | Yes | FX3-MOC100000 | 1057833 |
| Motion Control For connecting two encoders | No | FX3-MOC100000 | 1057833 |
| | Yes | FX3-MOC100010 | 1112300 |
| Analog input module Connection of two analog sensors | No | FX3-ANA020002 | 1051134 |
| | Yes | FX3-ANA020012 | 1112299 |

¹⁾ For more challenging ambient conditions (e.g., resistance to sulfur).

Relay modules

Table 196: Ordering data of relay modules

| Part | Protective coating ¹⁾ | Type code | Part number |
|---|----------------------------------|--------------|-------------|
| Relay module 2 normally open contacts and 1 24 V DC signal output, plug-in spring terminals | No | UE410-2R04 | 6032677 |
| | Yes | UE410-2R0401 | 1118380 |
| Relay module 4 normally open contacts and 2 24 V DC signal outputs, plug-in spring terminals | No | UE410-4R04 | 6032676 |
| | Yes | UE410-4R0401 | 6053182 |
| Safety relay Output expansion module for OSSDs 2 enabling current paths | No | RLY3-OSSD1 | 1085343 |

| Part | Protective coating ¹⁾ | Type code | Part number |
|---|----------------------------------|------------|-------------|
| Safety relay Output expansion module for OSSDs 4 enabling current paths | No | RLY3-OSSD4 | 1099971 |

¹⁾ For more challenging ambient conditions (e.g., resistance to sulfur).

14 Accessories

14.1 Accessories for the safety controller

Table 197: Accessories for the safety controller

| Part | Type code | Part number |
|---|--------------------|-------------|
| Plug-in spring terminals | - | 2045890 |
| Plug-in screw terminals | - | 2045891 |
| EFI cable thin, 6.9 mm, PVC, sold by the meter | - | 6030921 |
| Flexi Line cable, shielded, twisted pair, PVC, 2 × 0.22 mm ² (AWG 23), sold by the meter | - | 6029448 |
| Flexi Link cable, shielded, twisted pair, 2 × 2 × 0.34 mm ² (AWG 22), sold by the meter | - | 6034249 |
| Configuration cable 2 m, M8, D-Sub | - | 6021195 |
| Configuration cable 3 m, USB-A, USB Mini-B | - | 6042517 |
| Configuration cable 3 m, M8, angled, open end | - | 6036342 |
| Configuration cable, M8 on USB-A, 2 m | DSL-8U04G02M025KM1 | 6034574 |
| Configuration cable, M8 on USB-A, 10 m | DSL-8U04G10M025KM1 | 6034575 |

14.2 Accessories for the motion control module

Encoder/motor feedback connection units

Table 198: Encoder/motor feedback connection unit

| Part | Protective coating ¹⁾ | Type code | Part number |
|---|----------------------------------|---------------|-------------|
| Facility for connecting two encoder/motor feedback systems Connection to the FX3-MOCx motion control module: D-sub, female connector, 15-pin | No | FX3-EBX1 | 2079867 |
| Facility for connecting one encoder/motor feedback system Connection to the FX3-MOCx motion control module: D-sub, female connector, 15-pin Connection for additional encoder/motor feedback connection units: D-sub, female connector, 9-pin | No | FX3-EBX3 | 2068728 |
| Facility for connecting two encoder/motor feedback systems Connection to the FX3-MOCx motion control module: D-sub, female connector, 15-pin and HD D-sub, female connector, 15-pin | No | FX3-EBX4 | 2068729 |
| | Yes | FX3-EBX400012 | 2117330 |

¹⁾ For more challenging ambient conditions (e.g., resistance to sulfur).

Connecting cables

Table 199: Connecting cable for FX3-MOCx and FX3-EBXx

| Part | | Type code | Part number |
|--|-------|-----------|-------------|
| <ul style="list-style-type: none"> Shielded, twisted pair 1× Micro D-sub, male connector, 15-pin, straight 1× D-sub, male connector, 15-pin, straight | 2 m | – | 2067798 |
| | 10 m | – | 2067799 |
| <ul style="list-style-type: none"> Shielded, twisted pair 1× Micro D-sub, male connector, 15-pin, angled 1× D-sub, male connector, 15-pin, straight | 0.5 m | – | 2111541 |
| | 2 m | – | 2077261 |
| | 10 m | – | 2077262 |

Pin assignment, [see table 39, page 70](#)

Table 200: Connecting cable for FX3-EBX3 and FX3-EBX4

| Part | | Type code | Part number |
|---|-------|-----------|-------------|
| <ul style="list-style-type: none"> Shielded, twisted pair 1× D-sub, male connector, 9-pin, straight 1× D-sub, male connector, 15-pin, straight | 0.3 m | – | 2078260 |
| | 2 m | – | 2067800 |
| | 10 m | – | 2067801 |

Pin assignment, [see table 40, page 70](#)

Table 201: Connecting cable for direct encoder connection

| Part | | Type code | Part number |
|---|------|-----------|-------------|
| Sine/Cosine encoder, e.g., DFS60S Pro <ul style="list-style-type: none"> Shielded, twisted pair 1× Micro D-sub, male connector, 15-pin, angled 1× M12, female connector, 8-pin, straight | 1 m | – | 2094403 |
| | 3 m | – | 2094426 |
| | 5 m | – | 2094427 |
| | 10 m | – | 2094428 |
| SSI encoder <ul style="list-style-type: none"> Shielded, twisted pair 1× Micro D-sub, male connector, 15-pin, angled 1× M12, female connector, 8-pin, straight | 1 m | – | 2094402 |
| | 3 m | – | 2094431 |
| | 5 m | – | 2094432 |
| | 10 m | – | 2094433 |
| SSI + Sin/Cos encoder, e.g., AFS/AFM60Spro <ul style="list-style-type: none"> Shielded, twisted pair 1× Micro D-sub, male connector, 15-pin, angled 1× M12, female connector, 12-pin, straight | 1 m | – | 2094372 |
| | 3 m | – | 2094434 |
| | 5 m | – | 2094435 |
| | 10 m | – | 2094436 |

Pin assignment

- [see table 43, page 73](#)
- [see table 44, page 74](#)
- [see table 45, page 74](#)

Table 202: Connecting cable for directly connecting two encoders

| Part | | Type code | Part number |
|--|-------|-----------|-------------|
| <ul style="list-style-type: none"> Shielded, twisted pair 1× Micro D-sub, male connector, 15-pin, straight Flying leads | 2 m | - | 2067893 |
| <ul style="list-style-type: none"> Shielded, twisted pair 1× Micro D-sub, male connector, 15-pin, angled Flying leads | 1.1 m | - | 2098351 |
| | 2 m | - | 2077263 |

Pin assignment, see table 41, page 71

Table 203: Y-connecting cable for directly connecting two encoders

| Part | | Type code | Part number |
|---|--------------------------|-----------|-------------|
| <ul style="list-style-type: none"> Shielded, twisted pair 1× Micro D-sub, male connector, 15-pin, angled 2× M12, female connector, 8-pin, straight | 0.21 m / 0.21 m / 0.41 m | - | 2094381 |
| | 0.16 m / 0.14 m / 0.14 m | - | 2116199 |
| | 0.21 m / 2.74 m / 2.74 m | - | 2100634 |
| | 1.9 m / 0.49 m / 0.27 m | - | 2117540 |
| | 2.7 m / 0.69 m / 0.19 m | - | 2117541 |
| <ul style="list-style-type: none"> Shielded, twisted pair 1× Micro D-sub, male connector, 15-pin, angled 2× flying leads | 0.21 m / 1.5 m / 1.5 m | - | 2121173 |

Pin assignment, see table 42, page 72

14.3 Accessories for the diode module

Table 204: Diode module DM8-A4K

| Part | Type code | Part number |
|--|-----------|-------------|
| Diode module for connecting several short-circuit-forming safety pressure mats | DM8-A4K | 6026142 |

14.4 Accessories for muting

Table 205: Muting lamp and cable

| Part | Type code | Part number |
|---------------------------------|-----------|-------------|
| Muting lamp with mounting kit | - | 2129217 |
| LED muting lamp with 2 m cable | - | 2033118 |
| LED muting lamp with 10 m cable | - | 2033119 |

15 Glossary

| | |
|------------------------|--|
| AWG | American Wire Gage: standardization and classification of wires and cables according to type, diameter, etc. |
| CCF | Common cause failure. Failures of various units due to a single event, whereby these failures do not cause each other. |
| Control input | <p>A control input receives signals, e.g. from the machine or from the control. Use of control inputs is how the protective device receives information about the conditions at the machine, e.g., if there is a change of operating mode. If the protective device is configured appropriately, it will activate a different monitoring case after receiving a new control input.</p> <p>The control input information must be transmitted reliably. Generally, at least 2 separate channels are used to do this.</p> <p>Depending on the device, a control input can be realized as a static control input or a dynamic control input.</p> |
| Dangerous state | <p>A dangerous state is a status of the machine or facility, where people may be injured. Protective devices prevent this risk if the machine is operated within its intended use.</p> <p>The figures in this document always show the dangerous state of the machine as movement of a machine part. In practice, there are different dangerous states, such as:</p> <ul style="list-style-type: none"> • Machine movements • Electrical parts • Visible and invisible beam • A combination of multiple hazards |
| EDM | External device monitoring |
| EFI-pro | <p>EFI-pro ¹¹⁾ is an Ethernet-based network for general and safety-related data communication.</p> <p>EFI-pro allows for easy device identification, addressing, configuration, and diagnostics.</p> <p>Devices can exchange data via EFI-pro, such as control signals, safety-related shut-off signals, and diagnostics data.</p> <p>An EFI-pro network can have various structures (topologies), e.g., with cables running from one central device to all the others (star topology) or with cables running from one device to the next (line topology). Different topologies can be combined within one EFI-pro network to form a hybrid topology.</p> |
| ESD | Electrostatic discharge |
| ESPE | Electro-sensitive protective device |
| EtherCAT | <p>EtherCAT® (Ethernet for Control Automation Technology) is an Ethernet-based network used in industrial automation.</p> <p>With the Safety over EtherCAT® (FSoE, FailSafe over EtherCAT) protocol extension, EtherCAT® is also suitable for safety-related data communication.</p> |
| EtherNet/IP | <p>EtherNet/IP™ (EtherNet Industrial Protocol) is an Ethernet-based network used in industrial automation.</p> <p>EtherNet/IP™ implements the CIP™ (Common Industrial Protocol) based on the Ethernet and TCP/IP protocol family.</p> <p>EtherNet/IP™ with the CIP Safety™ protocol extension is also suitable for safety-related data communication.</p> |

11) Enhanced Function Interface-pro based on EtherNet/IP™ – CIP Safety™.

| | |
|-----------------------------------|--|
| External device monitoring | <p>The external device monitoring (EDM) monitors the status of downstream contactors.</p> <p>In order to use external device monitoring, positively guided contactors must be used to switch off the machine. If the auxiliary contacts of the positively guided contactors are connected to the external device monitoring, the external device monitoring checks whether the contactors switch correctly when the OSSDs are switched off.</p> |
| FPLC | Fail-safe programmable logic controller |
| Hazardous area | Hazardous area is any space within and/or around machinery in which a person can be exposed to a hazard. (ISO 12100) |
| Incremental encoder | An incremental encoder generates electrical pulses proportional to a movement. Various physical quantities can be derived from these pulses, e.g. speed and distance covered. |
| OFF state | The OFF state is the status of the outputs of the protective device, where the controlled machine is triggered to quit its dangerous state and the start-up of the machine is prevented (e.g., the voltage at the OSSDs is LOW, so that the machine is switched off and remains still). |
| ON state | The ON state is the status of the outputs of the ESPE, where the controlled machine is permitted to operate (e.g., the voltage at the OSSDs is HIGH so that the machine can run). |
| OSSD | <p>Output signal switching device: signal output for the protective device, which is used for stopping the dangerous movement.</p> <p>An OSSD is a safety switching output. The functionality of each OSSD is tested periodically. OSSDs are always connected in pairs and must undergo dual-channel analysis for safety reasons. An OSSD pair is formed from 2 OSSDs that are connected and analyzed together.</p> |
| PFH_D | Probability of dangerous failure per hour |
| PL | Performance level (ISO 13849) |
| PROFINET | <p>PROFINET (Process Field Protocol) is an Ethernet-based network used in industrial automation.</p> <p>With PROFIsafe, PROFINET is also suitable for safety-oriented data communication.</p> |
| Protective field | The protective field is the area in which the test object specified by the manufacturer is detected by the electro-sensitive protective equipment (ESPE). As soon as the electro-sensitive protective device detects an object in the protective field, it switches the associated safety outputs to the OFF state. This signal can be passed to controllers resulting in the dangerous state coming to an end, e.g. to stop the machine or the vehicle. |

| | |
|------------------------|---|
| Reset | <p>When a protective device has sent a stop command, the stopped state must be maintained until a reset device is activated and the machine can be restarted in a second step.</p> <p>The reset brings the protective device back to the monitoring state after it has sent a stop command. The reset also quits the start-up or restart interlock of a protective device, so that the machine can be restarted in a second step.</p> <p>The reset must only be possible, when all safety functions and protective devices are functional.</p> <p>The reset of the protective device must not introduce any movement or dangerous situations itself. The machine is only permitted to start after the reset once a separate start command has been sent.</p> <ul style="list-style-type: none"> • Manual resets are performed using a separate, manually operated device, such as a reset pushbutton. • Automatic resets by the protective device are only permitted in special cases, if one of the following conditions is met: <ul style="list-style-type: none"> ○ It must not be possible for people to be in the hazardous area without triggering the protective device. ○ It must be ensured that no people are in the hazardous area during or after the reset. |
| Resolution | The resolution of an active opto-electronic protective device (also known as the sensor detection capability) is the minimum size of an object for it to be reliably detected. |
| Response time | The protective device's response time is the maximum time between the occurrence of the event leading to the sensor's response and supply of the switch-off signal to the protective device's interface (for example OFF state of the OSSD pair). |
| Safety function | Function of a machine whose failure can result in an immediate increase of the risk(s). (ISO 12100) |
| Safety output | <p>A safety output provides safety-related information.</p> <p>Safety outputs are OSSDs, for example, or safety-related information on a safety-related network.</p> |
| SIL | Safety integrity level |

16 Annex

16.1 Conformities and certificates

You can obtain declarations of conformity, certificates, and the current operating instructions for the product at www.sick.com. To do so, enter the product part number in the search field (part number: see the entry in the “P/N” or “Ident. no.” field on the type label).

16.1.1 EU declaration of conformity

Excerpt

The undersigned, representing the manufacturer, herewith declares that the product is in conformity with the provisions of the following EU directive(s) (including all applicable amendments), and that the standards and/or technical specifications stated in the EU declaration of conformity have been used as a basis for this.

- ROHS DIRECTIVE 2011/65/EU
- EMC DIRECTIVE 2014/30/EU
- MACHINERY DIRECTIVE 2006/42/EC

16.1.2 UK declaration of conformity

Excerpt

The undersigned, representing the following manufacturer herewith declares that this declaration of conformity is issued under the sole responsibility of the manufacturer. The product of this declaration is in conformity with the provisions of the following relevant UK Statutory Instruments (including all applicable amendments), and the respective standards and/or technical specifications have been used as a basis.

- Restriction of the Use of Certain Hazardous Substances in Electrical and Electronic Equipment Regulations 2012
- Electromagnetic Compatibility Regulations 2016
- Supply of Machinery (Safety) Regulations 2008

16.2 Note on standards

Standards are specified in the information provided by SICK. The table shows regional standards with similar or identical contents. Not every standard applies to all products.

Table 206: Note on standards

| Standard | Standard (regional) |
|----------------|---------------------|
| | China |
| IEC 60068-2-6 | GB/T 2423.10 |
| IEC 60068-2-27 | GB/T 2423.5 |
| IEC 60204-1 | GB/T 5226.1 |
| IEC 60529 | GB/T 4208 |
| IEC 60825-1 | GB 7247.1 |
| IEC 61131-2 | GB/T 15969.2 |
| IEC 61140 | GB/T 17045 |
| IEC 61496-1 | GB/T 19436.1 |
| IEC 61496-2 | GB/T 19436.2 |
| IEC 61496-3 | GB 19436.3 |
| IEC 61508 | GB/T 20438 |

| Standard | Standard (regional) |
|-------------|---------------------|
| | China |
| IEC 62061 | GB 28526 |
| ISO 13849-1 | GB/T 16855.1 |
| ISO 13855 | GB/T 19876 |

16.3 Checklist for initial commissioning and commissioning

Checklist for manufacturers/installers when installing the product

The details relating to the items listed below must be available no later than when the system is commissioned for the first time. However, these depend on the specific application (the requirements of which must be reviewed by the manufacturer or installer).

This checklist should be retained and kept with the machine documentation to serve as a reference during recurring thorough checks.

This checklist is not a substitute for initial commissioning or periodic thorough checks by qualified safety personnel.

| | |
|--|--|
| Have the safety rules and regulations been observed in compliance with the directives and standards applicable to the machine? | Yes <input type="checkbox"/> No <input type="checkbox"/> |
| Are the applied directives and standards listed in the declaration of conformity? | Yes <input type="checkbox"/> No <input type="checkbox"/> |
| Does the protective device correspond to the required PL/SIL and PFHd in accordance with ISO 13849 / IEC 62061 and the required type in accordance with IEC 61496? | Yes <input type="checkbox"/> No <input type="checkbox"/> |
| Are the required protective measures against electric shock in effect (protection class)? | Yes <input type="checkbox"/> No <input type="checkbox"/> |
| Has the safety function been checked in compliance with the test notes of this documentation? | Yes <input type="checkbox"/> No <input type="checkbox"/> |
| Is it ensured that a complete test of the safety functions is done after any configuration change of the product? | Yes <input type="checkbox"/> No <input type="checkbox"/> |

17 List of figures

| | | |
|-----|---|----|
| 1. | Example minimum construction of the Flexi Soft system with FX3-CPU0 and FX3-XTDI or FX3-CPU1 and FX3-XTIO..... | 18 |
| 2. | Maximum structure of the Flexi Soft system (without relay modules)..... | 18 |
| 3. | FX3-CPU0 main module..... | 20 |
| 4. | FX3-CPU1 main module..... | 21 |
| 5. | FX3-CPU2 main module..... | 22 |
| 6. | FX3-CPU3 main module..... | 23 |
| 7. | I/O module FX3-XTIO..... | 25 |
| 8. | Internal structure of the FX3-XTIO – safety inputs and test outputs..... | 26 |
| 9. | Internal structure of the FX3-XTIO – safety outputs..... | 26 |
| 10. | I/O module FX3-XTDI..... | 29 |
| 11. | Internal structure of the FX3-XTDI – safety inputs and test outputs..... | 30 |
| 12. | I/O module FX3-XTDS..... | 31 |
| 13. | Internal structure of the FX3-XTDS – safety inputs and test outputs..... | 31 |
| 14. | Internal structure of the FX3-XTDS – non-safe outputs..... | 32 |
| 15. | I/O module FX0-STIO..... | 33 |
| 16. | Internal structure of the FX0-STIO – non-safe inputs..... | 33 |
| 17. | Internal structure of the FX0-STIO – non-safe outputs..... | 34 |
| 18. | Motion Control FX3-MOCO..... | 35 |
| 19. | Motion Control FX3-MOC1..... | 37 |
| 20. | Analog input module FX3-ANA0..... | 40 |
| 21. | Relay module UE410-2RO..... | 41 |
| 22. | Relay module UE410-4RO..... | 41 |
| 23. | Internal structure of the UE410-2RO..... | 42 |
| 24. | Internal structure of the UE410-4RO..... | 42 |
| 25. | Mounting the module on the DIN mounting rail..... | 50 |
| 26. | Attaching the end pieces..... | 50 |
| 27. | FX3-CPU0 main module..... | 53 |
| 28. | FX3-CPU1 main module..... | 54 |
| 29. | FX3-CPU2 main module..... | 55 |
| 30. | FX3-CPU3 main module..... | 56 |
| 31. | FX3-XTIO I/O module..... | 57 |
| 32. | FX3-XTDI I/O module..... | 58 |
| 33. | FX3-XTDS I/O module..... | 59 |
| 34. | FX0-STIO I/O module..... | 60 |
| 35. | FX3-MOCx motion control module..... | 60 |
| 36. | FX3-EBX1 connection overview..... | 62 |
| 37. | FX3-EBX3 connection overview..... | 62 |
| 38. | FX3-EBX4 connection overview..... | 62 |
| 39. | M12 female connector, 8-pin..... | 72 |
| 40. | Female connector, M12, 12-pin..... | 73 |
| 41. | Female connector, M12, 8-pin..... | 74 |
| 42. | M12 female connector, 8-pin..... | 74 |
| 43. | FX3-ANA0 analog input module..... | 75 |
| 44. | UE410-2RO relay module..... | 76 |
| 45. | UE410-4RO relay module..... | 76 |
| 46. | Example of integrating a relay module into the Flexi Soft system..... | 77 |
| 47. | Wiring for the power supply to a Flexi Soft system..... | 78 |
| 48. | Circuit diagram for multiple pressure-sensitive safety mats with diode module DM8-A4K connected to the FX3-XTIO upstream..... | 84 |
| 49. | Circuit diagram for multiple pressure-sensitive safety mats with diode module DM8-A4K connected to the FX3-XTDI upstream..... | 84 |
| 50. | Internal circuitry for diode module DM8-A4K..... | 85 |
| 51. | Minimum distance a to reflective surfaces, correct mounting and alignment..... | 90 |

52. Minimum distance a as a function of distance D for testable safety single-beam sensors with aperture angle 10° (e.g. Wx12/24/27, Vx18).....90

53. Mutual mounting to avoid mutual optical interference.....91

54. Example for the connection of an FX3-XTIO I/O module to a OSSD1 safety relay.92

55. Connection of A/B incremental encoders with two outputs.....98

56. Connection of non-safe single-channel analog signal transmitters.....99

57. Connection of a safe single-channel analog signal transmitter..... 99

58. Connection of a safe dual-channel analog signal transmitter..... 100

59. Connecting Flexi-Link stations via EF11+2.....101

60. Connection of a Flexi-Line system.....102

61. Connect the cable shielding to the DIN mounting rail..... 103

62. Detaching the plug-in terminals..... 130

63. Disconnecting the plug connections.....130

64. Removing the modules from the DIN mounting rail.....131

65. Response times within a Flexi Soft system..... 132

66. Response times within a Flexi Soft system..... 138

67. Response times within a Flexi Link system..... 139

68. Maximum switching voltage with direct current, relay modules UE410-2RO/
UE410-4RO.....171

69. Electrical endurance of relay modules UE410-2RO/UE410-4RO.....171

70. Dimensioned drawing FX3-CPUx (mm)..... 173

71. Dimensioned drawing FX3-XTIO, FX3-XTDS, FX0-STIO, FX3-XTDI, UE410-2RO, and
UE410-4RO (mm).....174

72. Dimensional drawing for the FX3-ANAO (mm/in).....175

73. Dimensional drawing for the FX3-MOCO (mm)176

74. Dimensional drawing for the optimized dual encoder/motor feedback connection
box FX3-EBX1 (mm/in).....177

75. Dimensional drawing for the FX3-EBX3 encoder/motor feedback connection
(mm/in).....178

76. Dimensional drawing for the FX3-EBX4 dual encoder/motor feedback connection
box (mm/in).....179

77. Dimensioned drawing diode module DM8-A4K..... 180

18 List of tables

| | | |
|-----|---|----|
| 1. | Overview of the Flexi Soft documentation..... | 7 |
| 2. | Target groups and selected sections of these operating instructions..... | 9 |
| 3. | Modules, firmware versions, and software versions you will need..... | 14 |
| 4. | Overview of modules..... | 19 |
| 5. | System plug variants..... | 24 |
| 6. | Maximum permissible time until Low level is reached after output (Q1 to Q4) is deactivated..... | 27 |
| 7. | Fault detection time and fault response time on the FX3-XTIO..... | 28 |
| 8. | Achievable SIL and PL..... | 35 |
| 9. | Achievable SIL and PL..... | 37 |
| 10. | Pin assignment of the RS-232 interface on the FX3-CPUx..... | 43 |
| 11. | USB interface..... | 43 |
| 12. | System requirements for Flexi Link..... | 45 |
| 13. | Available data depending on connection type..... | 45 |
| 14. | System requirements for Flexi Line..... | 46 |
| 15. | Update rate of a Flexi Line system dependent on the maximum cable length and the size of the process image..... | 46 |
| 16. | Selection and settings of optical SICK muting sensors in muting applications..... | 47 |
| 17. | Output level of muting sensors..... | 47 |
| 18. | Pin assignment on the FX3-CPU0 main module with FX3-MLP0 system plug..... | 53 |
| 19. | Pin assignment at FX3-CPU1 main module with FX3-MPL0 system plug and at FX3-CPU2 main module with FX3-MPL1 system plug..... | 55 |
| 20. | Pin assignment on the FX3-CPU3 main module with FX3-MLP1 system plug..... | 56 |
| 21. | Pin assignment for the FX3-XTIO I/O module..... | 57 |
| 22. | Pin assignment for the FX3-XTDI I/O module..... | 58 |
| 23. | Pin assignment for the FX3-XTDS I/O module..... | 59 |
| 24. | Pin assignment for the FX0-STIO I/O module..... | 60 |
| 25. | Pin assignment of the Micro-D-Sub male connector of the FX3-MOCx..... | 61 |
| 26. | Encoder/motor feedback connection units..... | 62 |
| 27. | Description of the connections..... | 63 |
| 28. | C1 encoder connection, FX3-EBX1..... | 64 |
| 29. | C2 encoder connection, FX3-EBX1..... | 65 |
| 30. | 00C3 HD-D-Sub female connector, FX3-EBX1, for connection to FX3-MOCx..... | 65 |
| 31. | Encoder connection C1, FX3-EBX3..... | 66 |
| 32. | C2 terminal, FX3-EBX3..... | 66 |
| 33. | 00C3 HD-D-Sub female connector, FX3-EBX3, for connection to FX3-MOCx..... | 67 |
| 34. | C4 D-Sub female connector, FX3-EBX3..... | 67 |
| 35. | C1 encoder connection, FX3-EBX4..... | 68 |
| 36. | C2 encoder connection, FX3-EBX4..... | 68 |
| 37. | 00C3 HD-D-Sub female connector, FX3-EBX4, for connection to FX3-MOCx..... | 69 |
| 38. | Setting of supply voltage for the encoders at FX3-EBX3 and FX3-EBX4..... | 69 |
| 39. | Connecting cable for FX3-MOCx and FX3-EBXx..... | 70 |
| 40. | Connecting cable for FX3-EBX3 and FX3-EBX4..... | 70 |
| 41. | Connecting cables for two encoders with flying leads..... | 71 |
| 42. | Y-connecting cable for directly connecting two encoders..... | 72 |
| 43. | Connecting cable for direct connection of the AFS/AFM60Spro safety encoder.. | 73 |
| 44. | Connecting cable for directly connecting a Sine/Cosine encoder..... | 74 |
| 45. | Connecting cable for directly connecting an SSI encoder..... | 74 |
| 46. | Pin assignment for the FX3-ANA0 analog input module..... | 75 |
| 47. | Pin assignment for the UE410-2R0 relay module..... | 76 |
| 48. | Pin assignment for the UE410-4R0 relay module..... | 76 |
| 49. | Connection for emergency stop pushbutton..... | 80 |
| 50. | Functions with ES21..... | 80 |
| 51. | Connection of electro-mechanical safety switches..... | 80 |

| | | |
|------|---|-----|
| 52. | Connection of locking devices..... | 81 |
| 53. | Functions with electro-mechanical safety switches and locking devices..... | 81 |
| 54. | Connection of the E100..... | 81 |
| 55. | Functions with the E100..... | 81 |
| 56. | Connection of the two-hand control..... | 82 |
| 57. | Functions with type IIIA two-hand control..... | 82 |
| 58. | Functions with type IIIC two-hand control..... | 82 |
| 59. | Connection of pressure-sensitive safety mats and bumpers..... | 83 |
| 60. | Function of pressure-sensitive safety mats and bumpers..... | 83 |
| 61. | Connection of multiple pressure-sensitive safety mats with diode module DM8-A4K connected upstream..... | 83 |
| 62. | Connection of operating mode selector switch..... | 85 |
| 63. | Function with operating mode selector switch..... | 85 |
| 64. | Functions with volt-free contacts..... | 85 |
| 65. | Connection of magnetic safety switches with equivalent inputs (RE13, RE27)..... | 86 |
| 66. | Connection of magnetic safety switches with complementary inputs (e.g., RE11, RE21, RE31, RE300)..... | 86 |
| 67. | Functions with magnetic safety switches..... | 86 |
| 68. | Connection of inductive safety switches..... | 86 |
| 69. | Functions with inductive safety switches..... | 86 |
| 70. | Connection of the transponders..... | 87 |
| 71. | Functions with transponders..... | 87 |
| 72. | Connection of testable type 2 safety single-beam sensors..... | 87 |
| 73. | Functions with testable type 2 safety single-beam sensors..... | 88 |
| 74. | Connection of testable type 4 safety single-beam sensors..... | 88 |
| 75. | Functions with testable type 4 safety single-beam sensors..... | 88 |
| 76. | Connection of electro-sensitive protective devices..... | 91 |
| 77. | Facilities for connecting encoders..... | 95 |
| 78. | Possible lengths of cable and types for Flexi-Link connections..... | 101 |
| 79. | Possible lengths of cable and types for Flexi Line connections..... | 102 |
| 80. | MS LED..... | 108 |
| 81. | CV LED..... | 108 |
| 82. | EFI LEDs..... | 109 |
| 83. | LINE LED..... | 109 |
| 84. | MS LED on the FX3-XTIO I/O module..... | 110 |
| 85. | Input and output LEDs on the FX3-XTIO I/O module..... | 110 |
| 86. | MS LED on the FX3-XTDI I/O module..... | 111 |
| 87. | Input LEDs on the FX3-XTDI I/O module..... | 111 |
| 88. | MS LED on the FX3-XTDS I/O module..... | 112 |
| 89. | Input and output LEDs on the FX3-XTDS I/O module..... | 112 |
| 90. | MS LED on the FX0-STIO I/O module..... | 113 |
| 91. | Input/output LEDs on the FX0-STIO I/O module..... | 113 |
| 92. | Statuses indicated by the MS LED on the FX3-ANA0 analog input module..... | 114 |
| 93. | Statuses indicated by the input LEDs on the FX3-ANA0 analog input module.... | 114 |
| 94. | Displays of the MS LED on the FX3-MOCx motion control module..... | 115 |
| 95. | Statuses indicated by the LEDs on the UE410-2RO and UE410-4RO relay modules | 115 |
| 96. | Error codes and error messages in the Flexi Soft system and possible troubleshooting measures..... | 120 |
| 97. | Calculation of the maximum response time of the Flexi Soft system in milliseconds | 134 |
| 98. | Calculation of the response time for the digital inputs (E1) in milliseconds..... | 134 |
| 99. | Calculation of the response time for the digital outputs (A1) in milliseconds..... | 135 |
| 100. | Calculation of the response time for the input from an EFI-capable device (E2) in milliseconds..... | 135 |
| 101. | Calculation of the response time for the output to an EFI-capable device (A2) in milliseconds..... | 135 |

| | |
|--|-----|
| 102. Calculation of the response time for the input from a gateway (E3) in milliseconds | 136 |
| 103. Calculation of the response time for the output to gateway (A3) in milliseconds | 136 |
| 104. Calculation of the response time for the input from an FX3-MOCx (E4) in milliseconds | 136 |
| 105. Calculation of the response time for the output to an FX3-MOCx (A4) in milliseconds | 137 |
| 106. Calculation of the response time for the analog inputs (E5) in milliseconds | 137 |
| 107. Example for the calculation of the response time for the digital inputs (E1) | 138 |
| 108. Example for the calculation of the response time for the digital outputs (A1) on path 1 | 138 |
| 109. Example for the calculation of the response time of path 1 of a Flexi Soft system | 139 |
| 110. Example for the calculation of the response time for the input from an EFI-enabled device (E2) | 139 |
| 111. Example for the calculation of the response time for the digital outputs (A1) on path 2 | 139 |
| 112. Example for the calculation of the response time of path 2 of a Flexi Soft system | 139 |
| 113. Example for the calculation of the response time for the digital inputs (E1) from station A | 140 |
| 114. Example for the calculation of the response time for the output to an EFI-enabled device (A2) from station A | 140 |
| 115. Example for the calculation of the total response time of station A (from remote input to EFI) in a Flexi Link system | 140 |
| 116. Example for the calculation of the response time for the input from an EFI-enabled device (E2) from station B | 140 |
| 117. Example for the calculation of the response time for the digital inputs (E1) from station B | 141 |
| 118. Example for the calculation of the total response time of station B (remote input to local output) in a Flexi Link system | 141 |
| 119. Safety-related parameters CPUx | 141 |
| 120. General data CPUx | 141 |
| 121. Interfaces FX3-CPU0, FX3-CPU1, FX3-CPU2 and FX3-CPU3 | 142 |
| 122. Power supply unit (A1, A2) for CPU0, CPU1, CPU2 and CPU3 (via system plug MPL0 or MPL1) | 142 |
| 123. Mechanical data CPUx | 142 |
| 124. Ambient data CPUx | 143 |
| 125. Safety-related parameters XTIO | 143 |
| 126. General data XTIO | 144 |
| 127. Interfaces FX3-XTIO | 144 |
| 128. Power supply unit (A1, A2) for XTIO | 144 |
| 129. Safety inputs (I) XTIO | 144 |
| 130. Test outputs (X) XTIO | 145 |
| 131. Safety outputs (Q) XTIO | 145 |
| 132. Mechanical data XTIO | 147 |
| 133. Ambient data XTIO | 147 |
| 134. Safety parameters XTDI | 147 |
| 135. General data XTDI | 147 |
| 136. Interfaces XTDI | 148 |
| 137. Safety inputs (I) XTDI | 148 |
| 138. Test outputs (X) XTDI | 148 |
| 139. Mechanical data XTDI | 149 |
| 140. Ambient data XTDI | 149 |
| 141. Safety-related parameters XTDS | 149 |
| 142. General data XTDS | 150 |
| 143. Interfaces XTDS | 150 |

| | |
|---|-----|
| 144. Power supply unit (A1, A2) for XTDS..... | 150 |
| 145. Safety inputs (I) XTDS..... | 150 |
| 146. Outputs XY of the XTDS when used as test outputs..... | 151 |
| 147. Non-safety outputs (Y3 ... Y6, XY1 and XY2 when used as non-safety outputs) XTDS..... | 151 |
| 148. Mechanical data XTDS..... | 152 |
| 149. Ambient data XTDS..... | 152 |
| 150. General data STIO..... | 152 |
| 151. Interfaces STIO..... | 153 |
| 152. Power supply unit (A1, A2) for STIO..... | 153 |
| 153. Input circuit (I1 ... IY8) STIO..... | 153 |
| 154. Non-safety outputs (Y1 ... Y6 as well as IY7 and IY8) of the STIO..... | 153 |
| 155. Mechanical data STIO..... | 154 |
| 156. Ambient data STIO..... | 154 |
| 157. Safety-related parameters ANAO..... | 154 |
| 158. ANAO general data..... | 154 |
| 159. Interfaces ANAO..... | 155 |
| 160. Analog inputs (AI) ANAO..... | 155 |
| 161. Mechanical data ANAO..... | 156 |
| 162. Ambient data ANAO..... | 156 |
| 163. Safety-related parameters MOCO..... | 156 |
| 164. MOCO general data..... | 157 |
| 165. Interfaces MOCO..... | 157 |
| 166. Encoder connection at MOCO..... | 157 |
| 167. Mechanical data MOCO..... | 161 |
| 168. Ambient data MOCO..... | 161 |
| 169. Safety-related parameters MOCO..... | 161 |
| 170. MOC1 general data..... | 162 |
| 171. Interfaces MOC1..... | 162 |
| 172. Encoder connection at MOC1..... | 163 |
| 173. Mechanical data MOC1..... | 166 |
| 174. Ambient data MOC1..... | 166 |
| 175. General data EBX1, EBX3 and EBX4..... | 167 |
| 176. Mechanical data EBX1, EBX3 and EBX4..... | 167 |
| 177. Ambient data EBX1, EBX3 and EBX4..... | 167 |
| 178. EBX1: Voltage supply for encoder ENC1_24V and ENC2_24V (from FX3-MOCx) | 167 |
| 179. EBX3 and EBX4: On-board voltage supply U_{out} (from FX3-MOCx)..... | 168 |
| 180. UE410-2RO/UE410-4RO safety-related parameters..... | 168 |
| 181. PFH _D values of UE410-2RO/UE410-4RO..... | 169 |
| 182. UE410-2RO/UE410-4RO general data..... | 169 |
| 183. Input circuit (B1, B2) of the UE410-2RO/UE410-4RO..... | 170 |
| 184. Output circuit (13-14, 23-24, 33-34, 43-44) of the UE410-2RO/UE410-4RO.... | 170 |
| 185. Output circuit (Y14, Y24) of the UE410-2RO/UE410-4RO..... | 171 |
| 186. Mechanical data UE410-2RO/UE410-4RO..... | 172 |
| 187. Ambient data UE410-2RO/UE410-4RO..... | 172 |
| 188. General data diode module DM8-A4K..... | 172 |
| 189. Input data for diode module DM8-A4K..... | 172 |
| 190. Mechanical data diode module DM8-A4K..... | 173 |
| 191. Ambient data diode module DM8-A4K..... | 173 |
| 192. Ordering information for system plug..... | 181 |
| 193. Ordering data for main modules..... | 181 |
| 194. Ordering information for gateways..... | 181 |
| 195. Ordering data for extension modules..... | 182 |
| 196. Ordering data of relay modules..... | 182 |
| 197. Accessories for the safety controller..... | 184 |
| 198. Encoder/motor feedback connection unit..... | 184 |

| | |
|---|-----|
| 199. Connecting cable for FX3-MOCx and FX3-EBXx..... | 185 |
| 200. Connecting cable for FX3-EBX3 and FX3-EBX4..... | 185 |
| 201. Connecting cable for direct encoder connection..... | 185 |
| 202. Connecting cable for directly connecting two encoders..... | 186 |
| 203. Y-connecting cable for directly connecting two encoders..... | 186 |
| 204. Diode module DM8-A4K..... | 186 |
| 205. Muting lamp and cable..... | 186 |
| 206. Note on standards..... | 190 |

Australia

Phone +61 (3) 9457 0600
1800 33 48 02 – tollfree
E-Mail sales@sick.com.au

Austria

Phone +43 (0) 2236 62288-0
E-Mail office@sick.at

Belgium/Luxembourg

Phone +32 (0) 2 466 55 66
E-Mail info@sick.be

Brazil

Phone +55 11 3215-4900
E-Mail comercial@sick.com.br

Canada

Phone +1 905.771.1444
E-Mail cs.canada@sick.com

Czech Republic

Phone +420 234 719 500
E-Mail sick@sick.cz

Chile

Phone +56 (2) 2274 7430
E-Mail chile@sick.com

China

Phone +86 20 2882 3600
E-Mail info.china@sick.net.cn

Denmark

Phone +45 45 82 64 00
E-Mail sick@sick.dk

Finland

Phone +358-9-25 15 800
E-Mail sick@sick.fi

France

Phone +33 1 64 62 35 00
E-Mail info@sick.fr

Germany

Phone +49 (0) 2 11 53 010
E-Mail info@sick.de

Greece

Phone +30 210 6825100
E-Mail office@sick.com.gr

Hong Kong

Phone +852 2153 6300
E-Mail ghk@sick.com.hk

Hungary

Phone +36 1 371 2680
E-Mail erteakesites@sick.hu

India

Phone +91-22-6119 8900
E-Mail info@sick-india.com

Israel

Phone +972 97110 11
E-Mail info@sick-sensors.com

Italy

Phone +39 02 27 43 41
E-Mail info@sick.it

Japan

Phone +81 3 5309 2112
E-Mail support@sick.jp

Malaysia

Phone +603-8080 7425
E-Mail enquiry.my@sick.com

Mexico

Phone +52 (472) 748 9451
E-Mail mexico@sick.com

Netherlands

Phone +31 (0) 30 204 40 00
E-Mail info@sick.nl

New Zealand

Phone +64 9 415 0459
0800 222 278 – tollfree
E-Mail sales@sick.co.nz

Norway

Phone +47 67 81 50 00
E-Mail sick@sick.no

Poland

Phone +48 22 539 41 00
E-Mail info@sick.pl

Romania

Phone +40 356-17 11 20
E-Mail office@sick.ro

Singapore

Phone +65 6744 3732
E-Mail sales.gsg@sick.com

Slovakia

Phone +421 482 901 201
E-Mail mail@sick-sk.sk

Slovenia

Phone +386 591 78849
E-Mail office@sick.si

South Africa

Phone +27 10 060 0550
E-Mail info@sickautomation.co.za

South Korea

Phone +82 2 786 6321/4
E-Mail infokorea@sick.com

Spain

Phone +34 93 480 31 00
E-Mail info@sick.es

Sweden

Phone +46 10 110 10 00
E-Mail info@sick.se

Switzerland

Phone +41 41 619 29 39
E-Mail contact@sick.ch

Taiwan

Phone +886-2-2375-6288
E-Mail sales@sick.com.tw

Thailand

Phone +66 2 645 0009
E-Mail marcom.th@sick.com

Turkey

Phone +90 (216) 528 50 00
E-Mail info@sick.com.tr

United Arab Emirates

Phone +971 (0) 4 88 65 878
E-Mail contact@sick.ae

United Kingdom

Phone +44 (0)17278 31121
E-Mail info@sick.co.uk

USA

Phone +1 800.325.7425
E-Mail info@sick.com

Vietnam

Phone +65 6744 3732
E-Mail sales.gsg@sick.com

Detailed addresses and further locations at www.sick.com

